

INSTRUCTIONS FOR USE

EXCELENT PREMIUM 6; 8



Edition: 5 | effective from: 1. 1. 2013

Dear customer,

The **EXCELENT Premium** share sowing machines are high quality products of the company Farmet a.s., Czech Republic.

You can start to fully use the qualities of your machine after you have thoroughly studied the instructions for use. **The serial number of the machine is imprinted on the production label and recorded in the instructions for use (see Tab. 1). Please use this serial number whenever you order spare parts in case of a repair. The production label is located on the central frame near the pole.**

Use only spare parts for these machines according to the *Spare Part Catalogue* officially published by the producer, the company Farmet a.s. Česká Skalice.

Possibilities of Use of Your Machine

Share sowing machines are intended for areal sowing with the option to sow broad-line cultures into strips. The sowing machine is intended for sowing a wide range of farming products, such as cereal, pulses, oil bearing crops, clover crops, grass etc. The actual conditions for sowing individual farming products are stated below. The **EXCELENT Premium 6** machine is intended for aggregation with tractors with the output from 147 kW and **EXCELENT Premium 8** from 176 kW according to the soil conditions and depth of sowing. The optimal working speed is 8 - 12 km/hour. The machine allows additional fertilising by granulated fertilisers while sowing.

Production label of the machine **EXCELENT Premium 6**

| | | | |
|------------------------------------|--------------------|----|--|
| | | | |
| TYP / VARIANTA | EXCELENT Premium 6 | | |
| ČÍSLO SCHVÁLENÍ | 5718-03 | | |
| ROK VÝROBY / VÝROBNÍ ČÍSLO | | | |
| MAX. PŘÍPUSTNÁ HMOTNOST | 9 500 | kg | |
| MAX. PŘÍPUSTNÁ HMOTNOST NA NÁPRAVĚ | 7 600 | kg | |

Production label of the machine **EXCELENT Premium 8**

| | | | |
|------------------------------------|--------------------|----|--|
| | | | |
| TYP / VARIANTA | EXCELENT Premium 8 | | |
| ČÍSLO SCHVÁLENÍ | 5718-02 | | |
| ROK VÝROBY / VÝROBNÍ ČÍSLO | | | |
| MAX. PŘÍPUSTNÁ HMOTNOST | 10 000 | kg | |
| MAX. PŘÍPUSTNÁ HMOTNOST NA NÁPRAVĚ | 8 100 | kg | |

Tab. 1 – Characteristics of the machine and its accessories

| TYPE OF MACHINE | | |
|---|--------------------------|--------------------------|
| SERIAL NUMBER OF MACHINE | | |
| ACCESSORIES | YES | NO |
| Lathered axle wheels | <input type="checkbox"/> | <input type="checkbox"/> |
| Lathered wheels of the front central roll | <input type="checkbox"/> | <input type="checkbox"/> |
| Pre-emergent marker | <input type="checkbox"/> | <input type="checkbox"/> |
| Additional granulated fertilisation | <input type="checkbox"/> | <input type="checkbox"/> |
| Air brakes | <input type="checkbox"/> | <input type="checkbox"/> |
| Kirovec set | <input type="checkbox"/> | <input type="checkbox"/> |
| SPECIAL VERSION OR ACCESSORIES | | |
| | | |
| | | |

TABLE OF CONTENTS

| | |
|--|----|
| CRITICAL PARAMETERS OF THE MACHINE..... | 5 |
| Technical parameters..... | 5 |
| Safety warning..... | 5 |
| A. GENERAL INTRUCTIONS FOR USE..... | 6 |
| Protective equipment..... | 6 |
| B. TRANSPORTING THE MACHINE..... | 7 |
| C. MANIPULATING THE MACHINE BY LIFTING EQUIPMENT..... | 7 |
| D. TRANSPORTING THE MACHINE ON GROUND COMMUNICATIONS..... | 7 |
| E. WORK SAFETY LABELS..... | 8 |
| 1. DESCRIPTION OF THE MACHINE..... | 11 |
| Working parts of the machine..... | 11 |
| 2. ASSEMBLY OF THE MACHINE AT THE CUSTOMER'S SITE..... | 11 |
| 3. PUTTING INTO OPERATION..... | 12 |
| 3.1. Aggregation to the tractor..... | 12 |
| 3.2. Connecting the hydraulics..... | 13 |
| 3.3. Connecting the electronic unit..... | 13 |
| 3.4. Manipulating the machine from a truck..... | 14 |
| 3.5. Unfolding and folding machine..... | 15 |
| 3.6. Connectong the hydraulic motor of the fan..... | 19 |
| 4. ELECTRONIC SYSTEM OF THE MACHINE..... | 22 |
| 4.1. Division of displays..... | 24 |
| 4.2. Description of displays..... | 24 |
| 4.3. Controlling hydraulics..... | 26 |
| 4.3.1 Controlling Markers..... | 26 |
| 4.3.2 Controlling Rail Line Markers..... | 27 |
| 4.4. Operation of the main display..... | 27 |
| 4.4.1 Travel Sped of the Machine..... | 27 |
| 4.4.2 Fan speed..... | 27 |
| 4.4.3 Hectare Gauge..... | 27 |
| 4.4.4 Rail Line..... | 27 |
| 4.4.5 Engine Speed Check..... | 28 |
| 4.4.6 Regulation of the Sowing Batch..... | 28 |
| 4.4.7 Reading the Sowing..... | 28 |
| 4.4.8 Level of Seeds in the Container..... | 29 |
| 4.4.9 "Plough Turning End" Function..... | 29 |
| 4.4.10 "Presowing" function..... | 29 |
| 4.5. Operating display 2 – basic setting..... | 29 |
| 4.5.1 Setting Minimum Fan Speed..... | 29 |
| 4.5.2 Setting Acoustic Signal..... | 30 |
| 4.5.3 Setting the Number of Sensors and Change in Address..... | 30 |
| 4.5.4 Replacement of the Sowing Sensor and New Sensor Number Assignment..... | 30 |
| 4.5.5 Setting the Range of the Sowing Machine..... | 31 |
| 4.5.6 Setting the Range of the Sprayer..... | 31 |
| 4.5.7 Setting the Start of Sowing..... | 31 |
| 4.6. Operating display 3 – trial sowing..... | 31 |
| 5. FILLING UP THE SEED/FERTILIZER CONTAINER..... | 31 |
| 6. SELECTION OF THE SOWING BATCH..... | 32 |
| 6.1. Selection of the type of sowing..... | 32 |
| 6.2. Sowing tables..... | 33 |
| 6.3. Procedure for executing a trial sowing..... | 34 |
| 6.3.1 Setting the testing scales..... | 35 |
| 6.3.2 Opening the turnstile and hanging up the bag..... | 35 |
| 6.4. Setting the fine seeds sowing..... | 37 |
| 6.5. Selection of the sowing range and fertiliser according to speed..... | 38 |
| 7. ADJUSTMENT OF THE WORKING PARTS OF THE MACHINE..... | 39 |
| 7.1. Adjustment of the working depth of the machine..... | 39 |
| 7.1.1 Adjusting the Machine by TPM Arms of the Tractor..... | 40 |
| 7.1.2 Adjusting the Gates of Pneumatic Rolls..... | 40 |
| 7.1.3 Adjusting Front Land Levellers..... | 41 |
| 7.1.4 Adjusting the Harrowing..... | 42 |

| | | |
|-------|---|----|
| 7.2. | Share protection | 42 |
| 7.3. | Calibration the machine plane | 43 |
| 7.4. | Makers..... | 44 |
| 7.5. | Completion of sowing | 44 |
| 8. | SUMMARY OF TASKS BEFORE THE COMMENCEMENT OF WORK..... | 45 |
| 9. | MAINTENANCE AND REPAIRS OF THE MACHINE..... | 45 |
| 9.1. | Replacement of worn shares..... | 46 |
| 9.2. | Lubrication plan for the machine..... | 46 |
| 10. | STORING THE MACHINE..... | 48 |
| 11. | PROTECTION OF ENVIRONMENT | 48 |
| 12. | DISPOSAL OF THE MACHINE AFTER THE END OF ITS USABLE LIFE..... | 48 |
| 13. | MAINTENANCE AND TERMS OF GUARANTEE | 48 |
| 13.1. | Maintenance | 48 |
| 13.2. | Guarantee | 48 |
| | LETTER OF GUARANTEE..... | 50 |
| | CE CERTIFICATE OF CONFORMITY | 51 |

CRITICAL PARAMETERS OF THE MACHINE

- ^(x) The machine is designated for sowing common cereals and broad-line cultures in aggregation with an agricultural wheel or caterpillar tractor. Other uses exceeding the determined purpose are not permitted.
- ^(x) The machine is operated by a properly trained person.
- ^(x) The operator must not use the machine for other purposes, particularly:
 - ^(x) For transporting people on the construction of the machine,
 - ^(x) For transporting load on the construction of the machine,
 - ^(x) Aggregation of the machine with other tractive equipment than stated in Chapter “3.1/p.12”.

TECHNICAL PARAMETERS

Tab. 2 – Technical parameters of share sowing machines

| PARAMETERS | EXCELENT Premium 6 | | EXCELENT Premium 8 | |
|--|-------------------------------|---------------|-------------------------------|---------------|
| | No fertilisation | Fertilisation | No fertilisation | Fertilisation |
| Working width (mm) | 6 000 | | 8 000 | |
| Transport width (mm) | 3 000 | | | |
| Transport height (mm) | 3 200 | | 3 950 | |
| Total length of the machine (mm) | 7 400 | | | |
| Working depth (mm) | 0 – 70 | | | |
| Number of shares (number of sowing units) | 24 | | 32 | |
| Share distance (mm) | 250 | | | |
| Share overlap (mm) | 50 | | | |
| Sowing system ACCORD | 2 | | | |
| Sowing method | areal/strip | | areal/strip | |
| Seed container capacity (l) | 4000 | 2200 | 4000 | 2200 |
| Fertiliser container capacity (l) | - | 1800 | - | 1800 |
| Working capacity (ha/h) | 4,8-7 | | 6,4-10 | |
| Tractive instrument (kW) | 147* | | 176* | |
| Working speed (km/h) | 8 – 12 | | | |
| Maximum transport speed (km/h) | 25 | | | |
| Maximum slope accessibility (°) | 6 | | | |
| Tyre – transport dimension (type) | 6,5/80-15 8PR | | | |
| Tyre pressure 12.5/80-15 (kPa) | 480 | | | |
| Tyre pressure 4-8 (kPa) | 150 | | | |
| Max. permissible load on transp. axle (kg) | 6400 | | | |
| Standby weight of the machine (kg) | 6 700 | 6 700 | 8 400 | 8 400 |
| Oil filling capacity (l) and type | 50 l - HLP 46 DIN 51524-2 | | | |

* value applies to medium soil and working depth of 4 cm, actual tractive force may substantially change according to the depth of sowing, soil conditions, slope of the land, wear of working bodies and their adjustment

SAFETY WARNING



This warning symbol warns against an imminent dangerous situation that could lead to death or serious injury



This warning symbol warns against a dangerous situation that could lead to death or serious injury



This warning symbol warns against a situation that could lead to a small or minor injury. It also points out dangerous tasks related to the activity that could lead to an injury.

A. GENERAL INSTRUCTIONS FOR USE

- A.1** ^(x) The machine is produced in compliance with the latest technological conditions and approved safety regulations. However, the use of the machine may still cause injuries to the user or third persons or damage to the machine or occurrence of other material damages.
- A.2** ^(xx) Use the machine only in a technically unexceptionable condition, in compliance with its purpose, with awareness of potential risks and observance of safety instructions stated in this manual!
- Immediately eliminate all defects that could have a negative impact on safety!
- A.3** ⁽⁷⁾ The machine may only be operated by a person authorized by the owner under the following conditions:
- ⁽⁸⁾ He or she must have a valid driving licence in the relevant category,
 - ⁽⁹⁾ He or she must be verifiably informed on the safety rules of working with the machine and must have command of the operation of the machine in practice,
 - ⁽¹⁰⁾ The machine must not be operated by a minor (minors),
 - ⁽¹¹⁾ He or she must understand the meaning of warning symbols placed on the machine. Respecting the symbols is important for a safe and reliable operation of the machine.
- A.4** ⁽¹²⁾ Maintenance and service repairs may only be performed by a person:
- ⁽¹³⁾ Authorized by the owner,
 - ⁽¹⁴⁾ Trained in an engineering field with the knowledge of repairs of similar machinery,
 - ⁽¹⁵⁾ Verifiably informed on the safety rules of working with the machine,
 - ⁽¹⁶⁾ With a driving licence in the relevant category for repairs of the machine attached to a tractor.
- A.5** ⁽¹⁷⁾ The operator of the machine must ensure safety of other people during the work with the machine and its transportation.
- A.6** ⁽¹⁸⁾ The operator should not be on the construction of the machine during the work in the field or during the transportation ⇒ the operator must control the machine from the tractor cabin.
- A.7** ⁽¹⁹⁾ The operator may only enter the construction of the machine when the machine is off and secured against movement only in order to:
- ⁽²⁰⁾ adjust the working parts of the machine,
 - ⁽²¹⁾ repair and maintain the machine,
 - ⁽²⁹⁾ release or secure the ball valves of the axle,
 - ⁽²⁷⁾ secure the ball valves of the axle before tilting the side frame,
 - ⁽²⁸⁾ adjust the working parts of the machine after opening the side frame.
- A.8** ^(xxx) When climbing onto the machine, do not step on the tyres of the rolls or other revolving parts as they may roll over and you can seriously hurt yourself if you fall down.
- A.9** ⁽²²⁾ Any changes or adjustments of the machine may only be performed with a written consent of the producer. The producer is not responsible for any potential damages occurred as a result of non-compliance with this instruction. The machine must always be equipped with the prescribed accessories, equipment and gear including the safety labels. All warning and safety signs must be always legible and at their positions. They must be replaced if damaged or lost without delay.
- A.10** ⁽²³⁾ The instructions for use and the requirements of the safety at work must be always available to the operator.
- A.11** ⁽²⁴⁾ When operating the machine, the operator must not consume alcohol, medicine, narcotic and hallucinogenic substances that reduce attention and coordination abilities. If the operator has to take medicine prescribed by the physician or if he or she uses over the counter medicine, he or she must be informed by the physician whether he or she is able to reliably and safely operate the machine under these circumstances.

PROTECTIVE EQUIPMENT

In order to operate and maintain the machine, you need:

- Close-fitting clothing
- Protective gloves and goggles for protection from dust and sharp parts of the machine



B. TRANSPORTING THE MACHINE

B.1 ⁽¹⁾ The vehicle intended for the transportation of the machine must have at least the same bearing capacity as the weight of the transported machine is. The total weight of the machine is stated on the production label.



B.2 ⁽²⁾ The dimensions of the transported machine including the vehicle must comply with valid regulations for traffic on ground communications (decrees, acts).

 **B.3** ⁽³⁾ The transported machine must be always attached to the vehicle so that it cannot be released during transportation.

B.4 ⁽⁴⁾ The carrier is responsible for damages caused by the release of incorrectly or insufficiently attached machine to the vehicle.

C. MANIPULATING THE MACHINE BY LIFTING EQUIPMENT



C.1 ⁽¹⁾ The lifting equipment and binding instruments intended for manipulation with the machine must have at least the same bearing capacity as the weight of the manipulated machine is.

 **C.2** ⁽²⁾ The machine may only be attached for manipulation in designated places marked by stick-on labels showing a "chain". 

C.3 ⁽³⁾ When attached (suspended) in designated places, it is not allowed to move in the area of potential reach of the manipulated machine.

D. TRANSPORTING THE MACHINE ON GROUND COMMUNICATIONS

Transport Position of *EXCELENT Premium 6; 8*

- 
- Attach the machine to the tractor by hanging with the use of the two-point suspension equipment (TPM 3).
 - Lift the machine on the axle, move the ball valve into the position closed, Picture 18/p.17.
 - The side frames must be folded in the vertical position and into the machine so that they do not protrude through the boundary of the machine.
 - The machine must be equipped with removable shields displaying the boundaries, functional lighting and a board of rear label for slow vehicles (pursuant to EEC No.69).
 - The lighting must be turned on when in operation on ground communications.
 - The tractors must be equipped with a special light appliance with orange colour that must be turned on when in operation on ground communications.
- 
- The operator must drive with increased caution and consideration for other participants of the traffic.
 - The operator must secure the arms of the rear TPM of the tractor in the transport position when operating on ground communications. At the same time, the arms of the rear TPM of the tractor must be secured against swinging sideways.
- 
- **It is strictly forbidden to transport people or load on the machine or connect another machine, semi-trailer or additional equipment to it.**
 - The maximum transport speed on ground communications is **25 km/hour**.
 - For better safety, the folding and unfolding of the machine is blocked and it can only be done when the machine is fully lifted on the transport axle.

 **Transport is forbidden when visibility distance is reduced!**

 **The machine may only be operated on ground communications if it is equipped with air brakes (the customer will receive the MOT certificate). Otherwise, the machine must not be operated on ground communications!**

E. WORK SAFETY LABELS

Warning safety labels are used for the protection of the operator.

The following applies generally:

- A) Strictly observe the warning safety labels.
- B) All safety instructions also apply to other users.
- C) If the aforementioned “SAFETY LABEL” located on the machine is damaged or destroyed, THE OPERATOR MUST REPLACE IT WITH A NEW ONE!!!

The position, appearance and exact meaning of work safety labels on the machine are given in the following tables (Tab.3/p.8-9) and the picture (Picture 1, 2/p.10).

Tab.3 – stick-on warning safety labels placed on the machine

| WARNING SAFETY LABEL | TEXT TO THE LABEL | POSITION ON THE MACHINE |
|----------------------|---|-------------------------|
| | Read carefully the instructions for use before manipulation with the machine. Observe the instructions and safety rules when operating the machine. | P 1 H |
| | Driving the machine and transportation on its construction is strictly forbidden. | P 37 H |
| | When connecting and disconnecting, do not enter the area between the tractor and the machine. Do not enter that area unless the tractor and the machine are not moving and the engine is off. | P 2 H |
| | Stay beyond reach of the set Tractor – Agricultural Machine when the tractor engine is running. | P 6 H |
| | Secure the axle of the machine against an unexpected drop before its transportation. | P 13 H |
| | Secure the machine against unwanted movement by positioning its working parts (shares). | P 52 H |
| | Do not approach the rotary parts of the machine unless they are standing still, i.e. they are not rotating. | P 53 H |
| | Stay beyond reach of the lifted machine. | P 4 H |

| | | |
|--|---|-----------------------|
| | <p>When folding and unfolding the side frames and service bridge, stay beyond their reach.</p> | <p>P 50 H</p> |
| | <p>When tipping the service bridge, stay beyond its reach.</p> | <p>P 20 H</p> |
| | <p>When working with the machine as well as during its transportation, keep a safe distance from electric appliances.</p> | <p>P 39 H</p> |
| | <p>It is forbidden to fold and unfold the side frames of the machine on a slope or an inclined plane.</p> | <p>P 100 H</p> |
| | <p>Pictured positions of the lever and the hydraulic ball valve function located on the piston-rod.</p> | <p>P 101 H</p> |

Picture 1

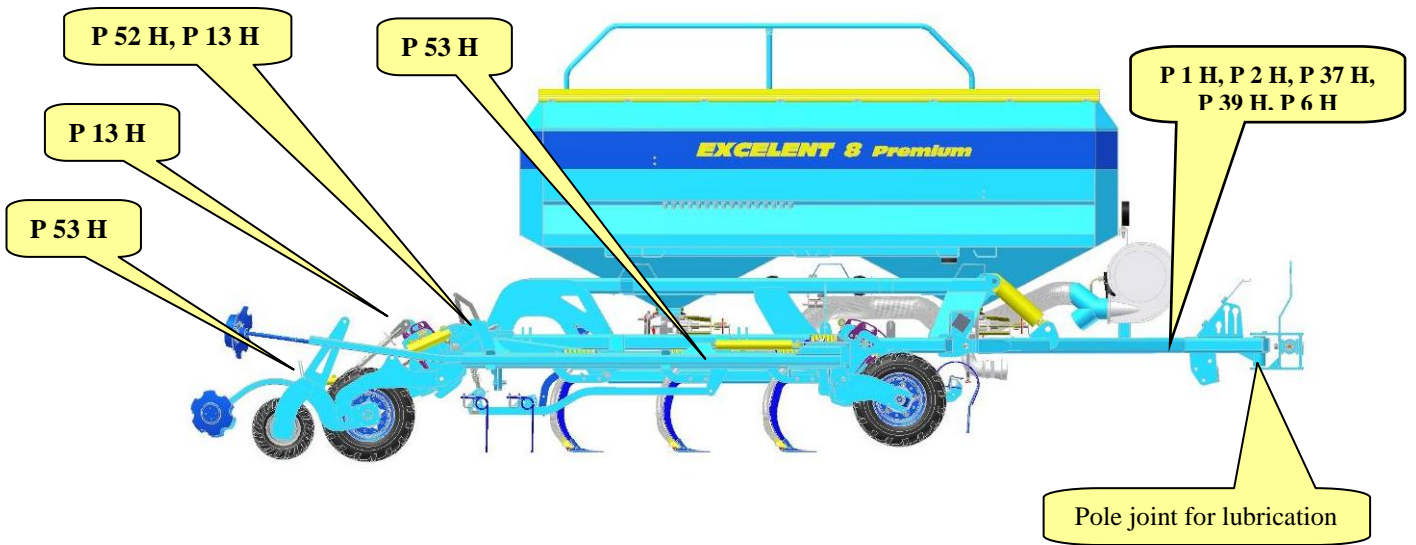

Picture 2

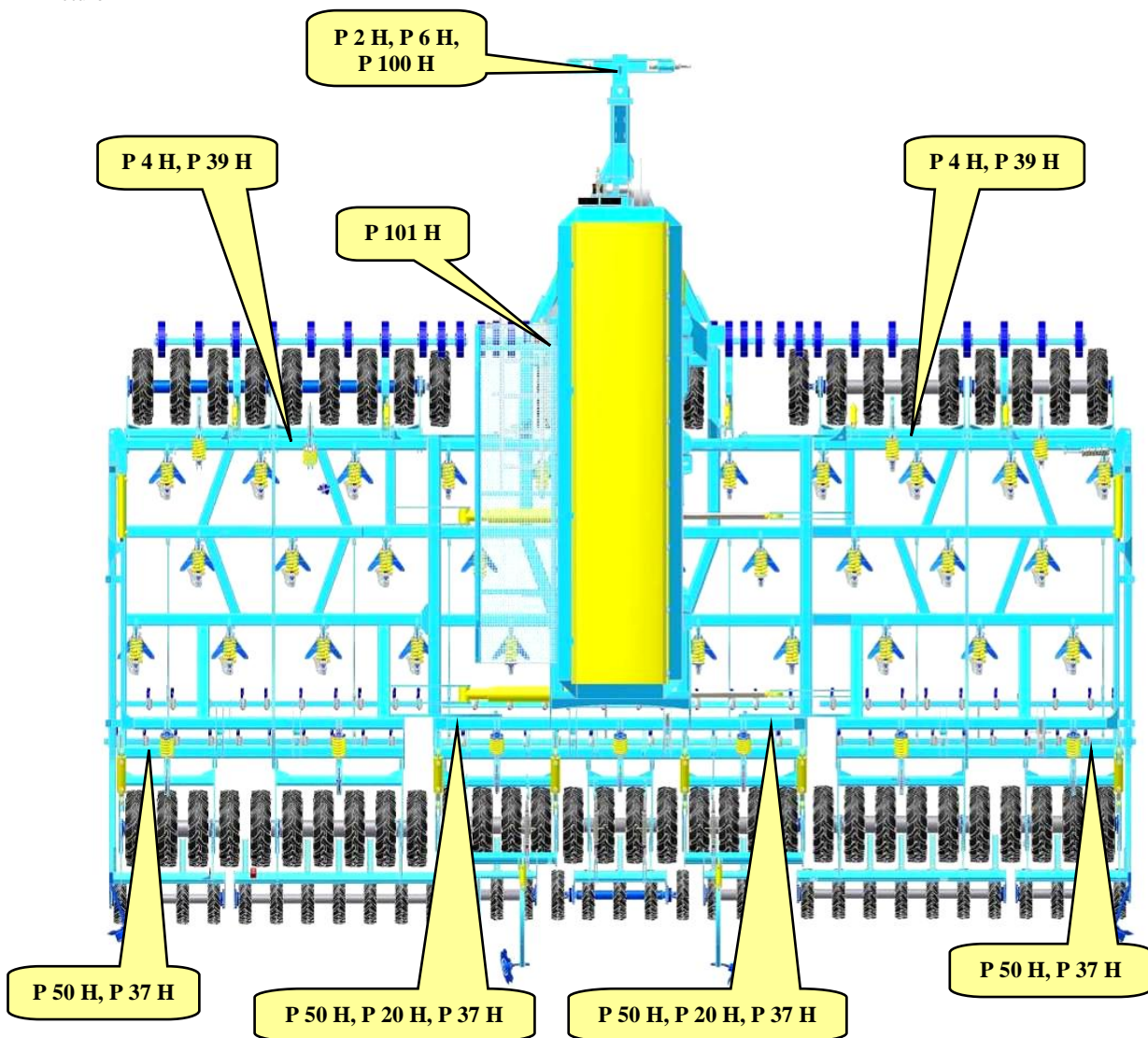

1. DESCRIPTION OF THE MACHINE

The **EXCELENT Premium** share sowing machine has a half-carried collapsible construction. The connection to the tractor is executed with the use of the pole with bolts of Cat III to the lower shoulders of the tractor three-point mounting. In the front of the machine, there are land levellers for levelling larger bumps, pneumatic edger rolls that solidify, level and compact soil with shares. Then there are working parts of the ploughshares located on the frame that are secured by a spring protection. Behind the shares, there are harrowing pins and a double pneumatic treader. Some of the tyres of the rear roll also serve for transport in the transport position. The seed container is equipped by a sowing mechanism commonly used in the standard ACCORD pneumatic sowing machines. Seeds are carried by a flow of air through seed tubes behind the shares where they are placed under the raised layer of soil. Seeds get to the solid underlay and they are covered by a processed layer of soil which is, moreover, treated by the harrowing pins and stiffened by the roll. The seeding mechanism is driven by electric motors. The fan for the transport of seeds is driven by hydraulic motor from the hydraulic circuit of the tractor. The machine is equipped with central markers and markers of rail lines. The electronic system of the machine allows checking the functions of the machine, regulation of the sowing batch and formation of rail lines. The transport wheels may be equipped with pneumatic brakes.

WORKING PARTS OF THE MACHINE

Picture 3 – Working parts of the machine

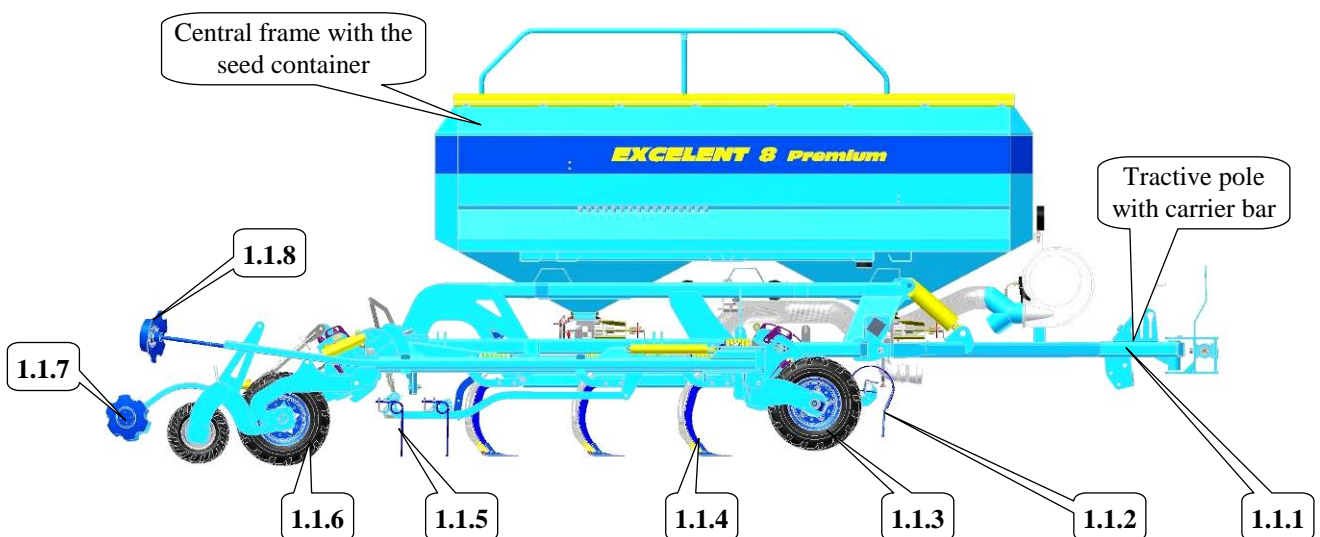

- | | | | |
|-------|--|-------|--|
| 1.1.1 | Tractive pole with a collapsible side leg | 1.1.5 | Section of harrowing pins |
| 1.1.2 | Front chisel leveller | 1.1.6 | Double pneumatic roll including the transport axle |
| 1.1.3 | Front pneumatic edger roll | 1.1.7 | Additional marker of rail lines |
| 1.1.4 | Section of shares in three rows; screw shares FARMET | 1.1.8 | Central markers |

2. ASSEMBLY OF THE MACHINE AT THE CUSTOMER'S SITE



- The owner must execute the assembly according to the producer's instructions, if possible in cooperation with a professional service technician determined by the producer.
- The owner must execute a functional test of all assembled parts after the completion of the assembly of the machine.
- The owner must ensure that the manipulation with the machine by lifting equipment corresponds with Chapter "C".

3. PUTTING INTO OPERATION



- Before you take over the machine, test and check it for any damages incurred during transportation and check that all parts included in the delivery note have been delivered.
- Before you put the machine into operation, read the instructions for use carefully, particularly chapters A-E p.5-10. Learn about the control elements of the machine and its overall function before the first use.
- When working with the machine, observe the instructions in the manual as well as generally valid rules for the safety at work, protection of health, fire and traffic safety and protection of environment.
- The operator must check the machine before every use (putting into operation) for aspects in the field of completeness, safety at work, work hygiene, fire safety, traffic safety and protection of environment. If the machine shows signs of damage, it must not be put into operation.
- Execute aggregation of the machine with the tractor on an even and compact surface.
- When working on slopes, observe the lowest slope accessibility of the whole set **TRACTOR – MACHINE**.
- Before turning on the engine of the tractor, check that there are no people or animals in the working area of the set and press the warning sound signal.
- The operator is responsible for safety and for all damages caused by the operation of the tractor and the attached machine.
- The operator must observe technical and safety regulations of the machine determined by the producer when working with the machine.
- The operator must raise the machine when turning at the plough turning end, i.e. the working parts must not be in the ground.
- The operator must observe the prescribed working depths and speeds set in the instructions for use in Tab. 10/p.38 and 11/p.39 when working with the machine.
- The operator must lower the machine to the ground and secure the set against movement before leaving the cabin of the tractor.

3.1. AGGREGATION TO THE TRACTOR

- The machine may only be connected to a tractor whose standby weight equals or is higher than the total weight of the attached machine.
- The operator must observe all generally valid regulations for the safety at work, protection of health, fire safety and protection of environment.
- The operator may only attach the machine to a tractor which is equipped with a rear three-point mounting (TPM) and a functional undamaged hydraulic system.
- The table with the requirements for the tractive instrument for work with the machine:

Tab.4

| | | |
|--|---|---|
| ⁽⁵⁾ Requirement for the engine power of the tractor for EXCELENT Premium 6 | | 147 kW* |
| ⁽⁵⁾ Requirement for the engine power of the tractor for EXCELENT Premium 8 | | 176 kW* |
| ⁽⁶⁾ Requirement for TPM of the tractor | ⁽⁷⁾ distance of the bottom suspension hinges (at the axes of the hinges) | 1010±1,5 mm, (can be also set to 910±1,5 mm) |
| | ⁽⁸⁾ ∅ holes of the bottom suspension joints for the suspension hinge pins of the machine | ∅37,5 mm |
| ⁽⁹⁾ Requirement for the hydraulic system of the tractor | ^(x) circuit of the electric distributor | ⁽¹⁴⁾ Pressure in the circuit min.190 bar – max.230 60 l/min., 2 sockets for snap coupling ISO 12.5 |
| | ⁽¹⁹⁾ circuit of the hydraulic engine | ⁽²⁰⁾ Pressure in the filling branch min.130 bar– max.230 bar, 1 socket for snap coupling ISO 12.5 |
| | | ⁽²¹⁾ Pressure in the waste branch max.3 bar, 1 socket for snap coupling ISO 20 |

| | | | |
|---|--|---|--------|
| (12) Requirement for the air system of the tractor (if the machine is equipped with brakes) | (13) circuit of braking of the machine axle | (16) Pressure in the circuit min.6 bar – max. 15 bar, 1 clutch head for single circuit brakes | |
| (x) Requirement for the electric system of the tractor | (x) connection of the electronic system of the machine | 12V / 40 A | |
| | | + brown | + blue |

- Connect the machine with the carrier bar TPM to the lower arm of the tractor TPM and secure the TPM arms with pegs against disconnection.



When connecting the machine, there must not be any people in the area between the machine and the tractor.

3.2. CONNECTING THE HYDRAULICS

- Connect the hydraulics only if the hydraulic circuits of the machine and the tractor (aggregate) are without any pressure.
- The hydraulic system is under great pressure. Check regularly for leakages and immediately eliminate any visible damage to all distribution, tubes and screw joints.
- When checking for and eliminating leakages, use appropriate equipment.
- Use the plug (on the machine) and the socket (on the tractor) of the same type of snap coupling when connecting the hydraulic system of the machine to the tractor. Execute the connection of the snap coupling of the machine to the hydraulic circuits of the tractor according to Tab. 5.

Tab. 5 - Connection of the hydraulic circuits and setting up the flow of oil

| Circuit | Plug | Cover colour | Oil flow direction | Flow of oil |
|------------------------------------|----------|--------------|--------------------|---------------|
| Hydraulic motor of the fan | ISO 12,5 | red | pressure tube | 20 – 40 l/min |
| | ISO 20 | black | open waste | |
| Controls of the machine hydraulics | ISO 12,5 | blue | pressure tube | 50 – 60 l/min |
| | ISO 12,5 | white | reverse tube | |



In order to rule out unintentional movement of the hydraulics or movement caused by third persons (children, passengers), the controlling distributors in the tractor must be secured or blocked and the controlling unit switched off if the machine is not used or if it is in the transport position.



The parts of the hydraulic system of the machine that are under pressure must not be disassembled. The hydraulic oil causes serious injuries when it penetrates the skin under the high pressure. In case of injury, immediately seek a doctor.

3.3. CONNECTING THE ELECTRONIC UNIT

- Connect the electronic unit of the machine only when the tractor is standing still and is secured against movement and intervention by third persons.
- The requirements for the connection of the electronic unit are stated in Tab. 6./p. 14
- Put the display unit to a place in the tractor where it will not obstruct the driver's view and where it will be in the visual field of the operator, connect it to the power voltage and attach it to the socket on the pole of the sowing machine.

Tab. 6 - Connection of the electronic unit

| Type of unit | Type of supply socket | Supply | Poling |
|------------------|------------------------|------------------|---------|
| TM - 07 | Knife triple pole 40 A | 12 V/40 A | + brown |
| | | | - blue |
| Types of sockets | | | |
| type: A - knife | | type: B - pinned | |
| | | | |

* The connecting socket must not be turned on by the tractor key (best is directly from the battery) and the supply conductors must have a corresponding diameter of at least 2.5 mm².



ATTENTION the correct polarity of the connection in the socket!

Picture 4 – Connection socket at the pole of the machine

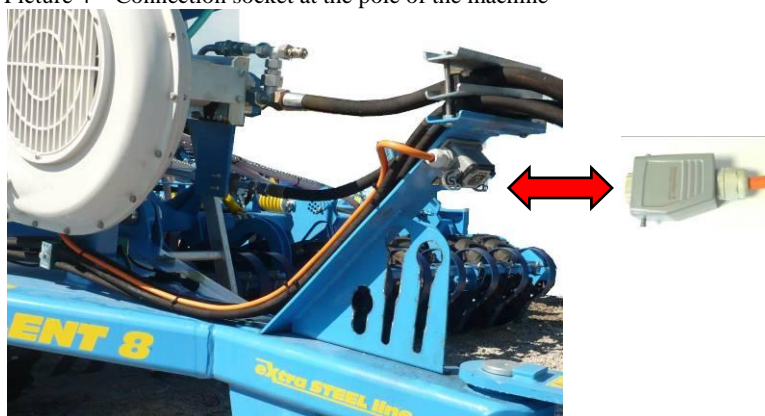

3.4. MANIPULATING THE MACHINE FROM A TRUCK

If the machine is transported to the customer in a complete state, it is pulled from the semi-trailer with the use of a tractor according to the following procedure:



1. **ATTENTION!!!** Before any manipulation from the semi-trailer, the operator must make sure that there is nobody near the semi-trailer!
2. Reverse the tractor to the semi-trailer and connect the machine to the arms of the tractor and the snap coupling of the hydraulics according to chapters 3.1 and 3.2. The machine is placed on the shares on the semi-trailer and it needs to be lifted to the transportation position.
3. Then release the ball valve of the axle (located on the frame on the left side under the service bridge and the access ladder).

Picture 6 – Location of the ball valve of the axle

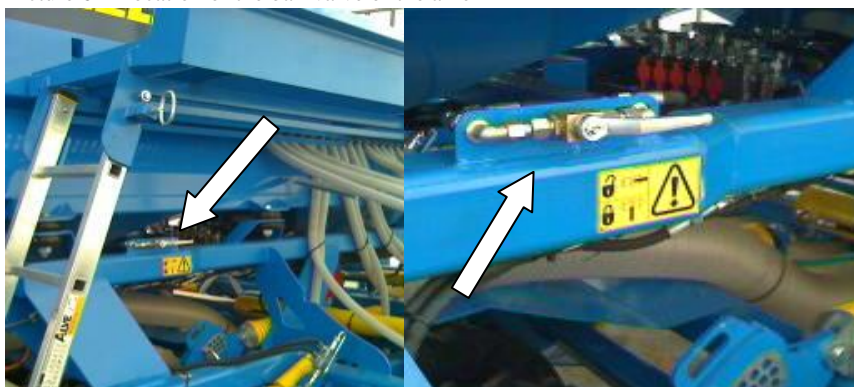

- Connect the electronics according to Chapter 3.3 (12V, 40A). When the system loads on the display, press the button for lowering/lifting the machine so that it is green, Picture 7, and lift the machine into the transport position by the hydraulic lever in the tractor. (Attention: the rolls of the side frames will tip out to the sides during lifting, see Picture 8).

Picture 7 – turning on lifting/lowering of the machine

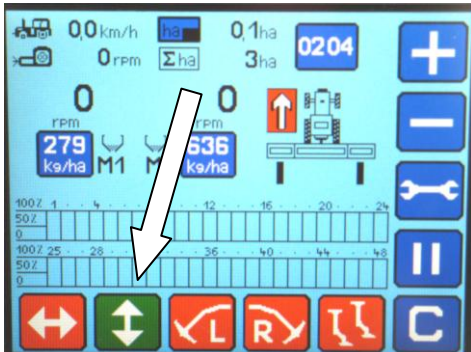

Picture 8 – Tipping out the side rolls



- When the machine is in the transport position, secure the ball valve of the axle.

Picture 9 – Securing the axle



- Then tip the rolls of the side frames back into the transport position by the hydraulic lever (folding back into the machine).
- Subsequently, you can remove the machine from the semi-trailer with increased caution and lay it by. Push the machine on flat land, lift it on the axle and lean it against the side leg. Secure the wheels of the axle against movement.

3.5. UNFOLDING AND FOLDING MACHINE



When executing any of the hydraulic movements, slow down the moving parts of the machine before position stop by choking a relevant valve on the tractor control!



- The hydraulics of the machine must be connected to a push-pull hydraulic circuit.
- The operator must ensure that there are no people or animals within the reach of the side frames during their unfolding or folding (i.e. in the place of their position stop) and that no one puts their fingers or other body parts into the area of the joints.
- Execute unfolding or folding on flat and solid surfaces or crosswise to a slope.
- Unfold or fold the machine only when it is lifted on the axle.
- Remove any soil stuck on the folding places as it may disturb the function and cause damage to the mechanics.
- Monitor the side frames during unfolding or folding and fold them smoothly until the end position.

3.5.1 Unfolding the Machine

- Release the catches of the side frames so that the exclamation mark is covered, which means that the frames are released, see Picture 10/p.16, and open the ball valve of the side frames, Picture 19/p.17.

Picture 10 – safety catches of the side frames

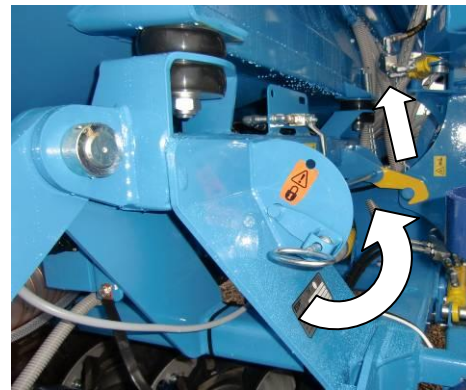
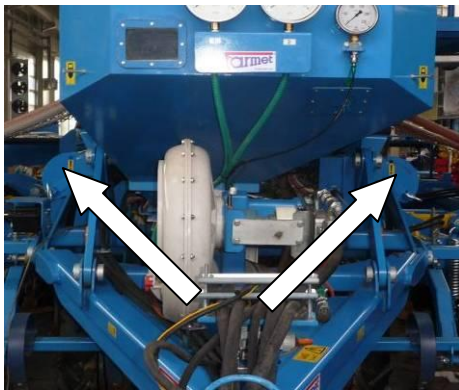

2. Press the button for unfolding/folding on the display, so that it is green.

Picture 12 – Unfolding/folding off

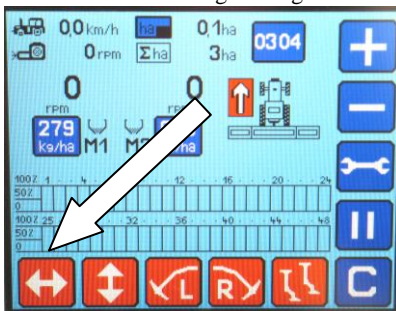

Picture 13 – Unfolding/folding on

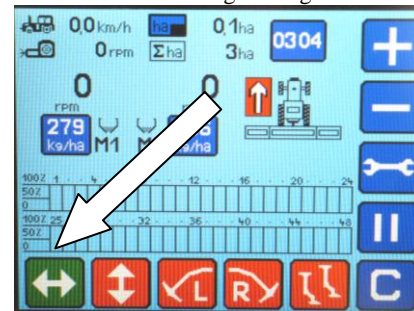

3. Release the pressure oil into the hydraulic circuit so that the machine unfolds.

Picture 14 – Unfolding the machine



Picture 15 – Unfolding the machine



4. After a complete unfolding of the machine, pressurize the circuit so that the pressure manometer shows pressure according to the relevant machine type. This is necessary for the proper function of side frames tracing.



| Pressure (bar) | MACHINE |
|----------------|--------------------|
| 30 | EXCELENT Premium 6 |
| 50 | EXCELENT Premium 8 |

After that turn off the function folding/unfolding on the display unit so that the button is red again and press the function lowering/lifting so that the button is green.

Picture 16 – Turning on lifting/lowering

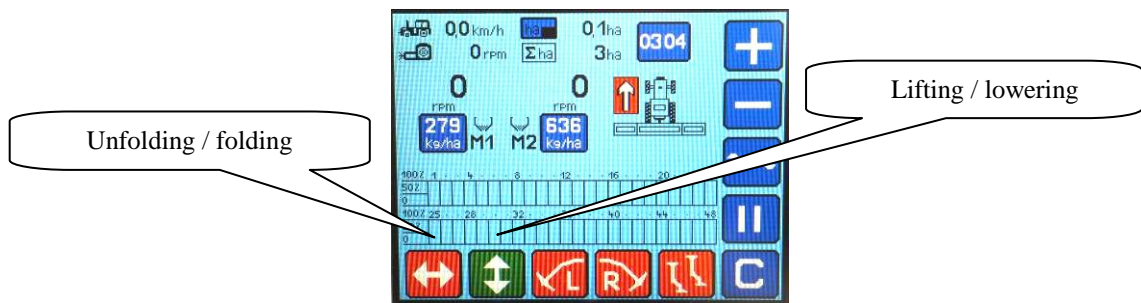

5. Release the pressure oil so that the machine is fully lifted and the piston rods of the edge sections are pushed out.

Picture 17 – Lifting the side sections of the rear rolls



6. Open the cocks of the ball valves of the piston rods for lifting the central section.

Picture 18 – Ball valve of the axle and side frames **CLOSED**

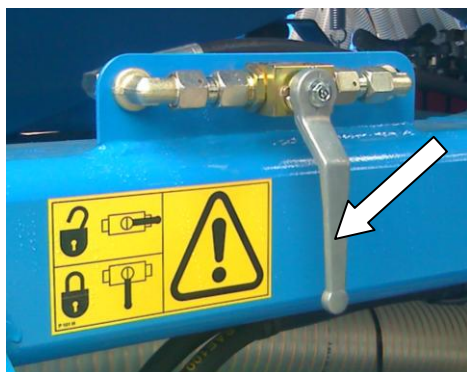

Picture 19 – Ball valve of the axle and side frames **OPEN**

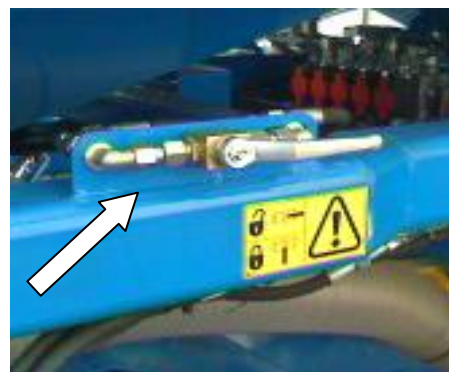

3.5.2 Folding the Machine

When folding the machine, progress in a reversed way:

1. Lift the machine fully and close the cocks of the ball valves of the axle, see Picture 18.
2. Turn off the function lifting/lowering on the display and turn on the function unfolding/folding, see Picture 20.

Picture 20 – Unfolding/folding on



3. Release the pressure oil so that the machine folds into the transport position.
4. Turn off the function unfolding/folding on the display and turn on the function lifting/lowering, see Picture 21.

Picture 21 – Lifting/lowering on

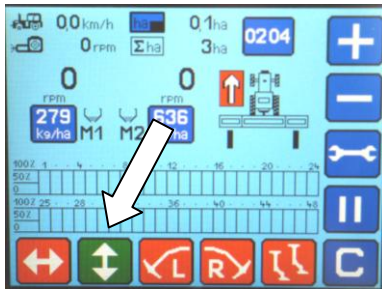

5. Release the pressure oil so that the wheels of the edge sections fold back (piston rods are pulled in) see Picture 22.

Picture 22 – Folding the side rear rolls back

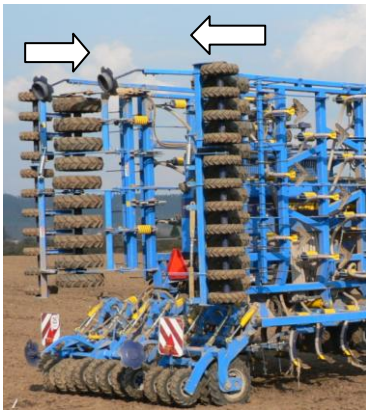

6. Turn off all the hydraulic functions on the display, see Picture 23.

Picture 23 – All hydraulic functions are off

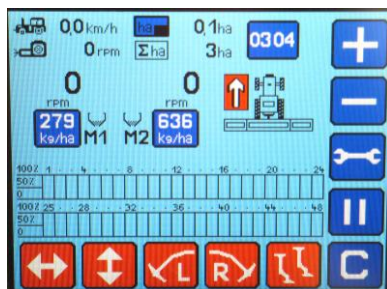

7. Secure the side frames for transport by the catches, see Picture 10/p.16 and the ball valve, see Picture 18/str.17.



Attention! Do not move in the area of the edge sections until their full securing by the catches and valve in case they fall down!

3.6. CONNECTONG THE HYDRAULIC MOTOR OF THE FAN

3.6.1 Description of the function

The hydraulic fan is powered directly from the tractor's hydraulic system.

For proper operation, the hydraulic pump of the tractor must supply sufficient amount of oil so that the fan revolutions are not affected by decreased number of revolutions of the tractor engine or by another hydraulic circle being switched on.

The fan revolutions are set by regulating the oil flow rate. To change the fan revolutions, the tractor must be equipped with regulation of the oil flow rate.

A pressure filter is incorporated in the hydraulic drive in such a way so as to catch any impurities coming to the hydraulic motor together with the oil. The hydraulic motor is thus protected from damage.

Picture 24.1 – Hydraulic drive

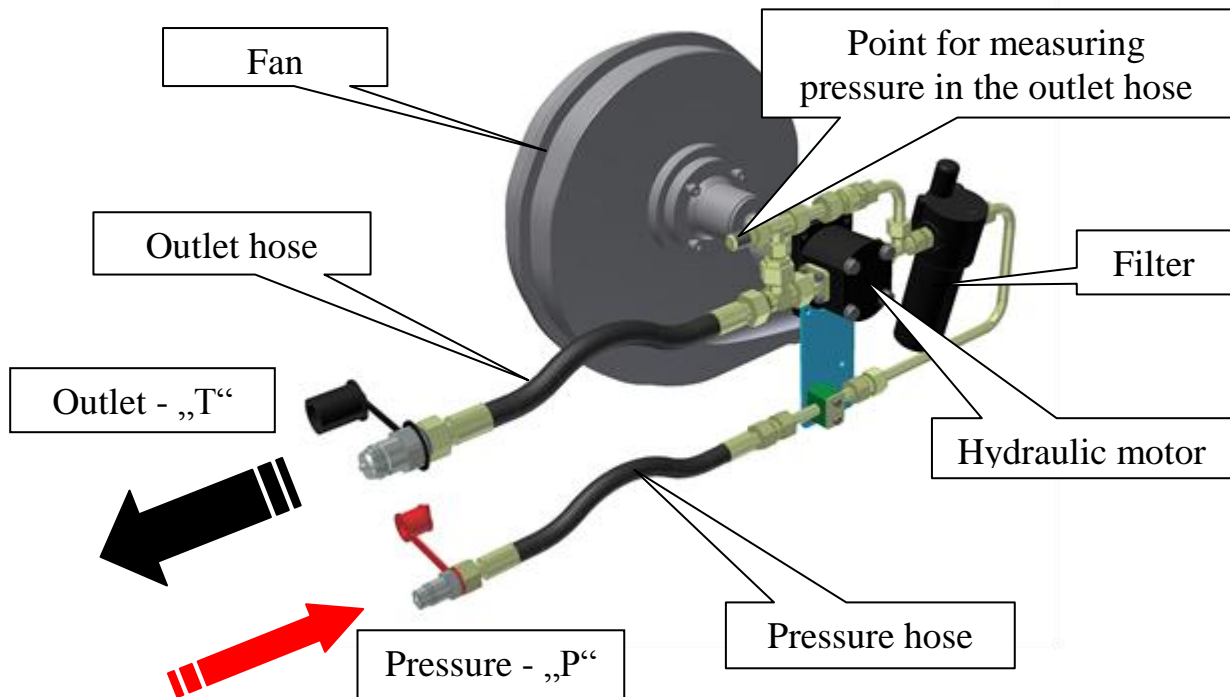

Tab. 7

| | | |
|------------------------|---|------|
| Rotary hydraulic motor | Capacity (cm ³ /rev.) | 8 |
| | Minimum revolutions (rpm) | 1000 |
| | Maximum revolutions (rpm) | 5000 |
| Pressure oil - „P“ | Minimum pressure in the “PRESSURE HOSE” (bar) | 130 |
| | Maximum flow rate in the “PRESSURE HOSE” (l/min.) | 40 |
| Outlet - „T“ | Maximum pressure in the “PRESSURE HOSE” (bar) | 5 |

3.6.2 Proper connection to the tractor



For proper connection, the following facts must be observed:

Outlet hose

- Do not connect the outlet hose to the tractor distributor! (pressure in the reverse branch would thus be increased)
- Large quick coupling on the outlet hose must not be confused with the small one
- Oil returning through the outlet pipe must not be throttled anywhere
- **Maximum allowed pressure value in the outlet hose is 5 bar**, higher pressure pushes the shaft seal out, which causes damage to the hydraulic motor fan

Pressure hose

- Connect the pressure hose to the circuit giving priority to the oil supply

Picture 24.2 – Position of quick couplings in the tractor

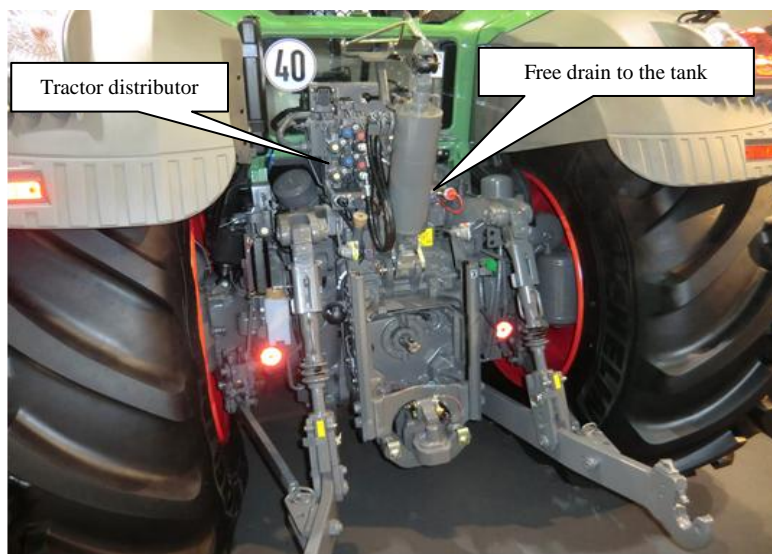

1. Connecting the outlet hose

Connect the outlet hose (outer \varnothing 27 mm) with the large quick coupling to the free drain to the tractor tank.



In case that there is no free drain to the tank attached to the tractor as standard, please contact the tractor manufacturer (dealer) for information regarding the possibilities of a free drain end piece.

Picture 24.3 – Outlet hose connection



2. Connecting the pressure hose

Connect the pressure hose (outer \varnothing 22 mm) with the small quick coupling to the tractor distributor.
Connect this hose to the circuit giving priority to the oil supply.

Picture 24.4 – Pressure hose connection



3.6.3 Commissioning

- When setting the required fan revolutions, the hydraulic oil must be warmed up.
- When commissioning the hydraulic drive, the fan revolutions (working air pressure on the pressure gauge in the hopper) must be set gradually.
- Fan revolutions (pressure on the pressure gauge) are set by regulating the oil flow rate in the tractor.
- If the hydraulic drive is started with cold oil, it is necessary to increase the motor revolutions gradually before the oil warms up.
- For setting the required revolutions for individual crops, please see chapter 4.4.2.
- During commissioning and the first handover, the technician in charge of the handover must inspect all connections of the hydraulic drive and measure pressure in the outlet hose. He must record the obtained results in the handover protocol.

3.6.4 Maintenance of the pressure filter

- It is necessary to check the state of the filter element fouling. If the filter cap shows red fields, the filter element must be replaced. The filter element is fouled when the indicator in the red field is moving constantly at normal operating temperature – the sensor and sensor function depend on oil viscosity and temperature.
- Dismantle the bottom filter body, remove the filter element, insert a new one and fit the filter body back. Rinse the filter body before you fit it back again.

Picture 25 – Diagram of the hydraulic drive of the fan

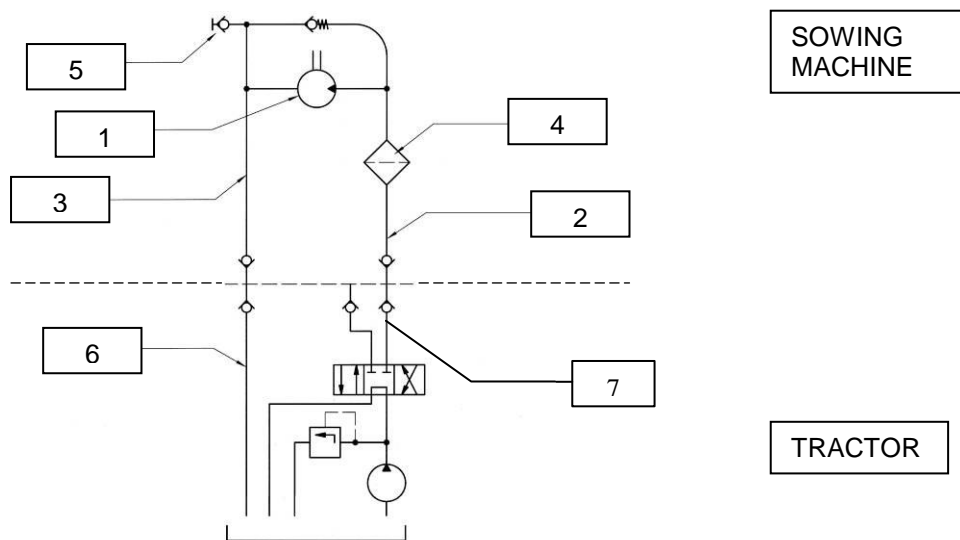

- | | |
|--------------------|-----------------------------------|
| 1. Hydraulic motor | 5. Measuring point |
| 2. Pressure hose | 6. Free drain to the tractor tank |
| 3. Outlet hose | 7. Tractor distributor |
| 4. Pressure filter | |



Warning!

Farmet a.s. is not liable for any damage of the hydraulic drive or the tractor caused by improper connection of the hydraulic drive.

4. ELECTRONIC SYSTEM OF THE MACHINE

General Instructions for Use:

- Connect the system with a three-pole plug to the power source 12 V (11 – 14.4V)
- The maximum current may reach up to 40 A
- Pay attention to proper poling (blue -, brown +)
- Connect all modules of the controlling system TM 07 before connecting to the power source
- Secure the connecting cables between the machine and tractor against mechanical damage and against heat stress from the hot parts of the tractor and hydraulic conduction
- Turn on the display after you have connected the system to the power source
- If an unusual situation occurs during the operation, disconnect the whole system from the power source for a short time
- If the current fuse blows, first find the cause of the defect or seek professional service
- Do not replace the current fuse with another item
- Some parts of the system may heat up to the temperature of 50°C during operation. If the temperature is higher, look for the cause or seek professional service
- Protect the display from water and temperatures below -20°C and above +60°C
- If you have to perform welding on the machine or the tractor, disconnect the unit from the power source and disconnect the connecting cables

Turning the Sowing and Off

Turning the sowing on and off is controlled by two sensors. The system is designed so that the sowing turns on at the beginning of recessing. Before the seeds go through the whole system of the pneumatic distribution, the machine has already recessed and the delay in the launch of sowing at the beginning of the patch is thus minimized. The sowing is turned off at the beginning of digging out.

TURNING ON THE SOWING

Turning on is controlled by an aerial sensor. The aerial sensor is set to turn on at the beginning of recessing. The sensitivity of the switching depends on the position of the sensor set between the axle frame and the main frame of the machine. It can be adjusted by loosening the screws (see the picture 26) and changing the position of the sensor towards the holder. Furthermore, the sensor turns on the control of the machine functions – see the chart Functions of the sensors.

TURNING OFF THE SOWING

Turning the sowing off (the electric motors of the seed feeders) is controlled by a pressure sensor located in the hydraulic circuit of the axle lifting. The sensitivity of this sensor is set to the pressure of 7 MPa. When the machine is digging out, the oil pressure is led to the hydraulic distributor and when the set value is reached, the switch turns on and the motors of the seed feeders turn off.



Therefore, move the lever for the hydraulic control to the **FLOATING POSITION** after the machine has been recessed!!!

All other functions of sowing are turned on until the machine has completely dug out and the aerial sensor turns on.

The sensitivity of the pressure and aerial sensors is standardly set by the producer. Only a professional service may change the setting.

Functions of the sensors:

| SENSOR | STATUS | FUNCTION |
|------------------------|--------|--|
| Pressure sensor | On | Stoppage of the operation of the electric motors of seed feeders, Showing the machine position - dug out ↑ |
| Aerial sensor | On | Reading rides |
| | On | Reading rail lines |
| | Off | Showing the machine position – recessed ↓ |
| | On | Stoppage of the control of the seed flow |
| | On | Stoppage of the reading of the level of seeds |
| | On | Stoppage of the reading of fan revolutions |
| | On | Stoppage of the counter of hectares |

Picture 26 – Aerial Sensor

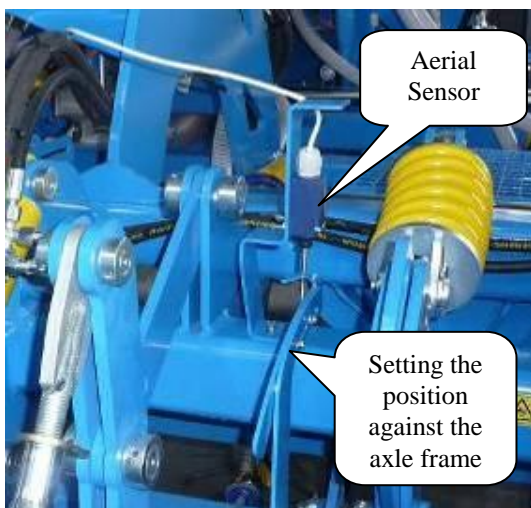

- Pressure Sensor



Radar

The radar provides a very exact measurement of the travel speed which is important for exact batch of seeds. Do not stay or move in the working area of the radar.

The buttons with the symbols plus and minus are used for setting the controlling unit. The display of adjustable values is graphically solved by buttons. You can regulate the value by plus or minus after pressing the button.

The plus and minus can be used for the regulation of the brightness of the display when no other buttons of adjustable values are pressed

4.1. DIVISION OF DISPLAYS

The display unit is divided into three screens. The screens are changed by pressing the key symbol. The first (basic) display is used for controlling the hydraulics and it contains all the data that the operator needs for work in the field. The second display is used for the basic setting of the sowing machine. The third display is used for setting and calibrating the required sown seeds. Pictures 27-29 show the individual screens. Their description is given below.

Picture 27 – Basic display

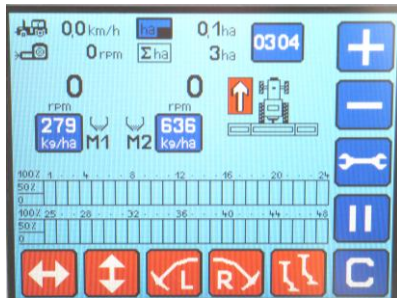

Picture 28 – Display No.2 Basic Setting

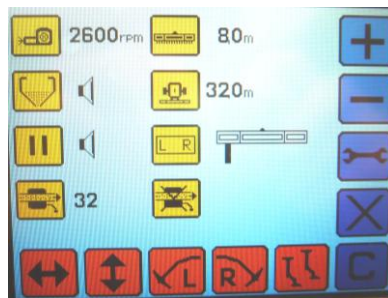

Picture 29 – Display No.3 Trial sowing

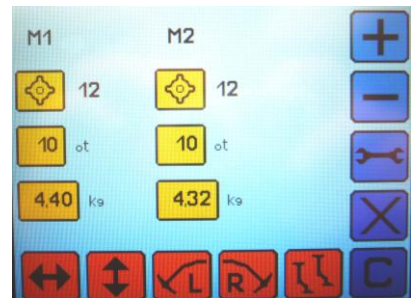

4.2. DESCRIPTION OF DISPLAYS

Picture 30 – Description of the buttons on the basic display

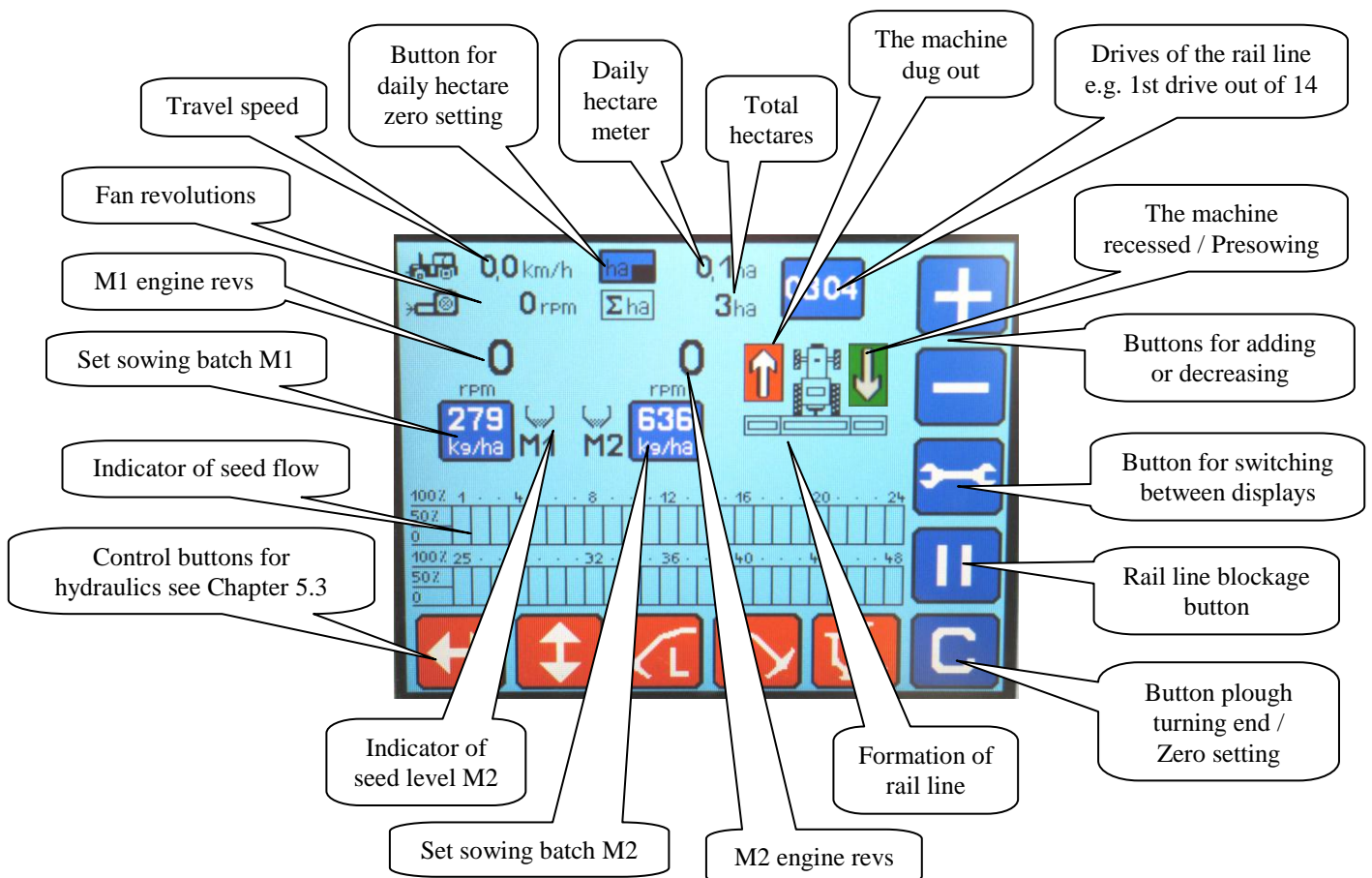

Picture 31 - Description of the buttons on Display 2 – basic setting

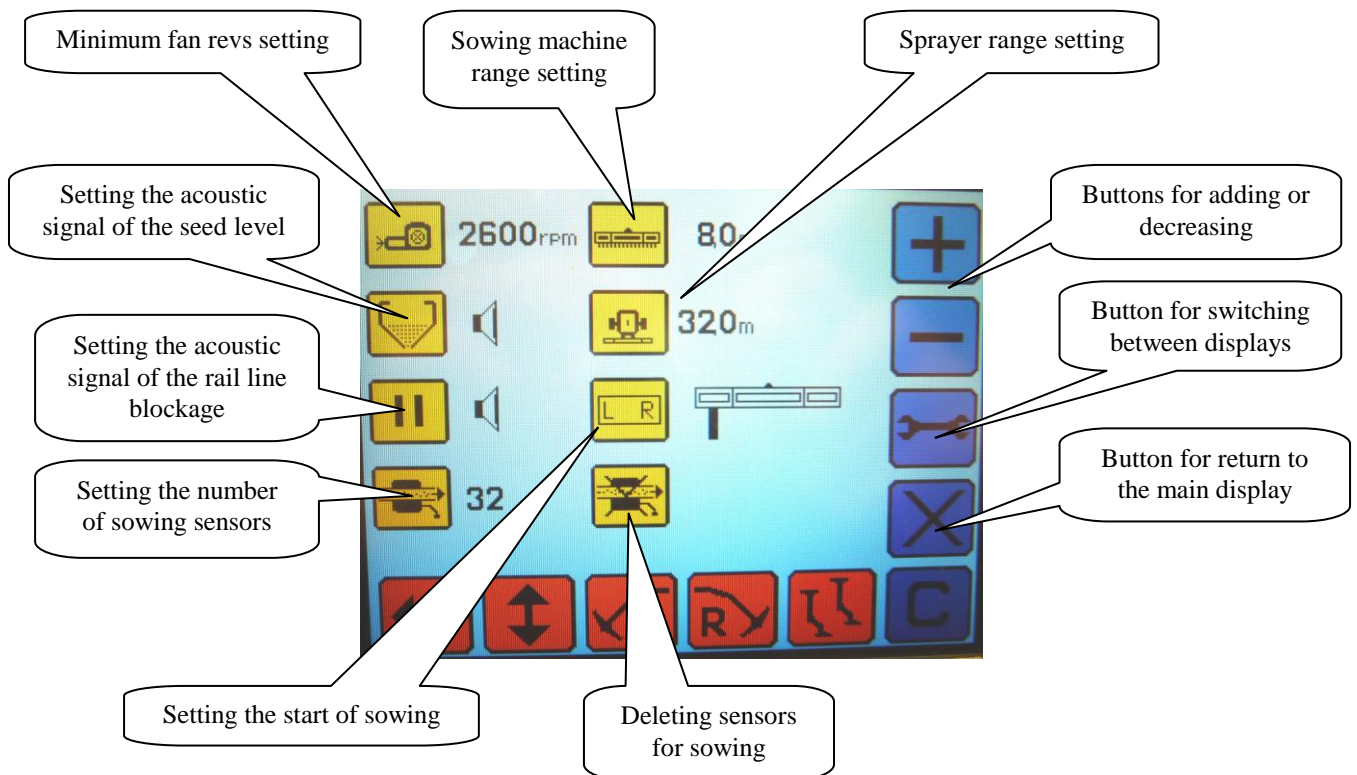

Picture 32 - Description of the buttons on Display 3 – Trial sowing

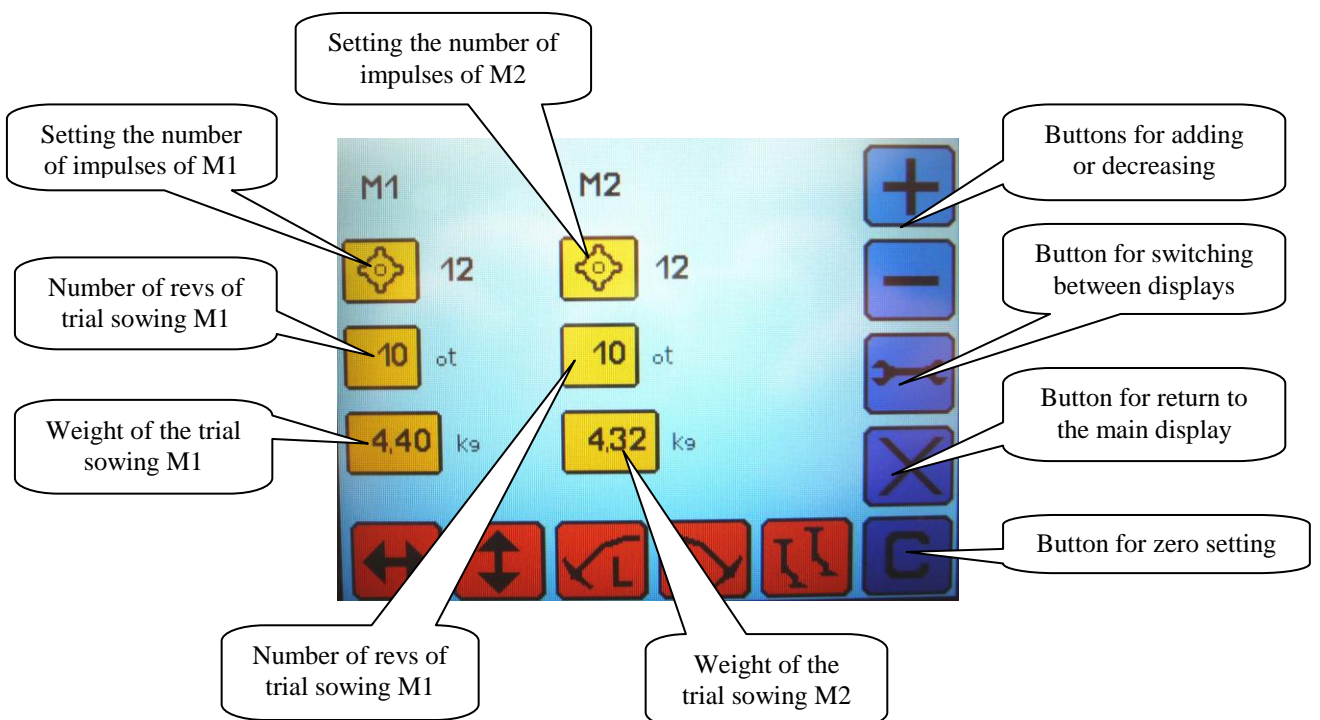

4.3. CONTROLLING HYDRAULICS

Picture 33 – Buttons for controlling hydraulics

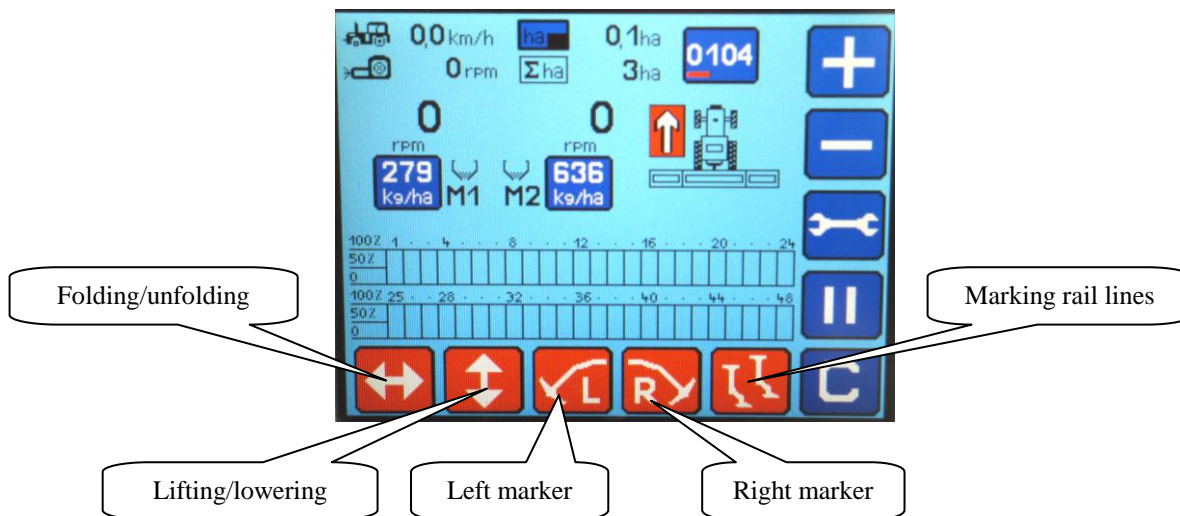

The controlling unit of the hydraulics allows setting of the required (one or more) functions of the hydraulics that are then performed together by releasing the pressure oil from the tractor in the required direction. As the picture shows, all hydraulic functions are situated in one row for simplicity and transparency. The operator selects the required functions by pressing button.

Red button = function is off

Green button = function is on

Control buttons for hydraulics are only functional on basic display 1.

Do not turn on the functions lifting/lowering and folding/unfolding at the same time.

When working, set the circuit for controlling the machine to the **FLOATING POSITION!!!**

4.3.1 Controlling Markers

Markers are controlled automatically. Before the commencement of work, the operator must set the function of the left or right marker by pressing the relevant buttons on the basic display. Then, after each run, the run is recorded at the moment of complete recess and the second marker is set automatically. The marker setting may be changed at any time by pressing the button with the active marker and subsequent pressing of the second marker. The markers are then switched over automatically again after the recording of the run.

If no marker is selected before the run, the machine will work without them.

It is also possible to start with both markers at the same time. In such a case, unfold one of them with the function of recessing, when unfolded, turn off the function and then turn on the other one and the function of recessing. The second marker will unfold when we start recessing.

Folding the marker during sowing when driving around an obstruction (post etc.): turn off the function lifting/lowering of the machine while driving and release the pressure oil from the tractor. When you drive around the obstruction, unfold the marker and turn on the function lifting/lowering (all of which is performed during the drive and sowing).

When sowing the dead centres, it is standard to drive in one direction and thus select the “plough turning end” function described in Chapter 4.4.9/str.29.

4.3.2 Controlling Rail Line Markers

If the function of rail line markers is on (provided that the machine is equipped with them), the marker turns on automatically at the moment of the formation of rail lines, see Picture 35. Marking is recessed when the machine is lowered into the swathe.

Example; functions lifting/lowering of the machine, right marker and rail line marker are on. In Picture 34 the function of markers is on but the indicator shows that the rail line is not formed and therefore the marking is not functional. The indicator in Picture 35 shows the formation of rail lines and therefore the marking is functional and operating.

Picture 34 – Example of the marking function

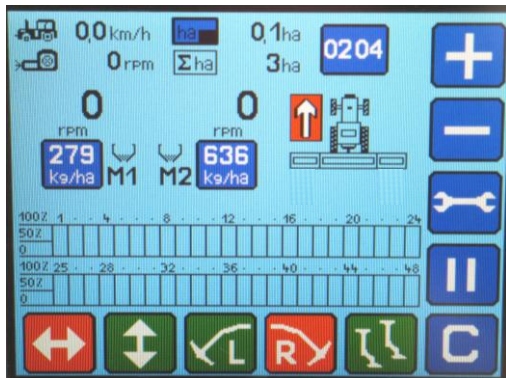

Picture 35 – Formation of rail lines

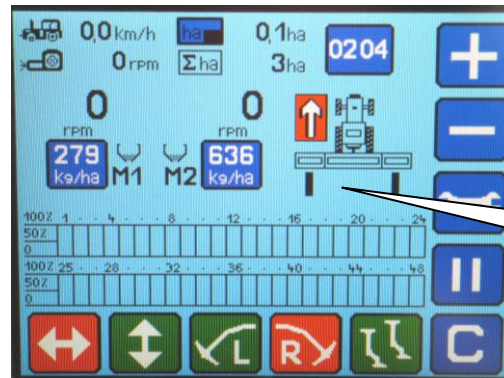

Indicator of the rail line formation

4.4. OPERATION OF THE MAIN DISPLAY

All deviations from normal condition are diagnosed by flashing of the relevant icon in red colour on the display of the controlling unit and by acoustic signal!!!

4.4.1 Travel Sped of the Machine

This value is indicated by the radar on the sowing machine and it is for information only. The value should be the same as of the tractor; it may be different when the tractor wheels slip. The difference in speed is not indicated.

4.4.2 Fan speed

Shows the current fan speed. When the speed drops down below the set value (see Chapter 4.5.1./p.29), the fan icon starts flashing red and the acoustic signal sounds. When the machine starts without the fan on, the defect is also indicated.

Emergency setting of the sensor: if there is a failure of the rev sensor and we do not have a spare one, the system will display an error in revs during the drive. The acoustic signal may be turned off in this status by setting the minimal revs to the “0” value (see Chapter 4.5.1/p.29)

4.4.3 Hectare Gauge

This function has two modes. There is a daily hectare gauge that can be set to zero by pressing the button for zero setting of the daily hectare gauge, Picture 30/p.24 and then by pressing button “C”. The total hectare gauge shows the summary area which the machine has sown since its operation. This value cannot be deleted. Both gauges only measure sowing, i.e. they do not MEASURE during plough turning ends, crossings and other manipulations with lifted machine!!

4.4.4 Rail Line

The individual runs of the machine are counted during the operation of the machine. On the basis of the set programme, rail lines are created after a certain number of runs (cycles). The runs are calculated on the basis of the sensor of the lift of the machine. It is possible to enter these runs any time and change them by pressing the button for rail lines and then adding or decreasing.

When editing, a red line appears below the numbers to show what is edited. The rail line can be also blocked when driving around obstructions, when sowing at the edges of the fields etc. Blocking is performed by pressing the rail line blockage button. The blockage can be supported by an acoustic signal. When working without rail lines for a longer period of time, the acoustic signal can be turned off

Picture 36 – Adjusting the rail line runs

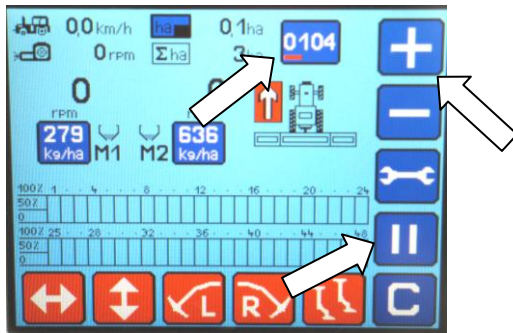

Picture 37 – Blocking the rail lines

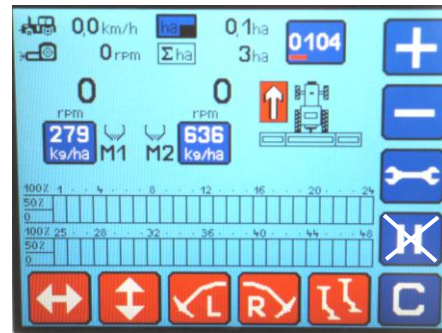

4.4.5 Engine Speed Check

The engine speed is always displayed in two figures – current and informative. When the engines stop unexpectedly (forced), a red frame will show around the number of revolutions and a permanent acoustic signal will start. When the engines are only slowed down and thus do not reach the corresponding revolutions but keep on turning, again the red frame will show around the number of revolutions and an interrupted acoustic signal will start.

4.4.6 Regulation of the Sowing Batch

The sowing batch can be randomly adjusted (even during the drive). Press the button for setting of the batch and adjust the value by pressing plus or minus. When adjusting, a red line will appear below the number indicating editing. To leave editing, press the button of the batch again.

Picture 38 – Regulation of sowing batch M1

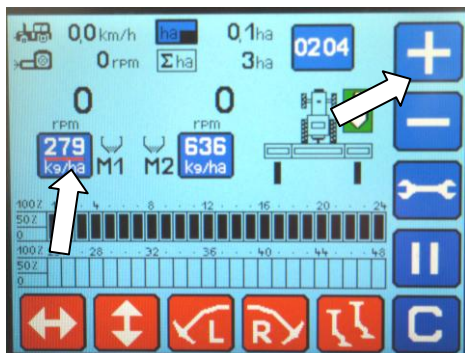

Picture 39 – Regulation of sowing batch M2

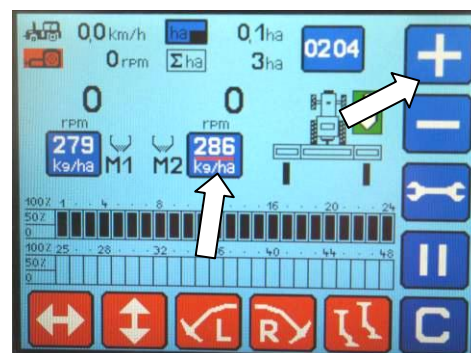

4.4.7 Reading the Sowing

This check of the flow of seeds in tubes shows whether the individual tubes are through. When a tube is clogged, there is graphic signalization. The check runs only when the machine is recessed and sowing. The fields for individual sensors are black when there are no problems with the sowing. When clogged, they turn white.

Example: Picture 40

Out of 32 sensors, tubes 2, 11, 18, 22, 24, 29 and 32 are clogged and the seeds do not go through them (they are not working).

Picture 40 – Check of the flow of seeds

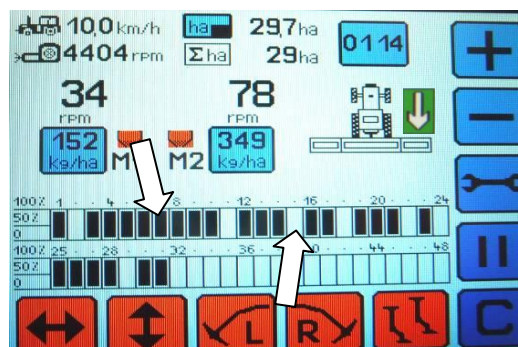

4.4.8 Level of Seeds in the Container

There are two sensors in the container that monitor the remaining level of seeds. These sensors can be adjusted according to the type of seeds or the needs of the operator. When the level drops below the set value, the sensor turns on a red frame around the sign for the level of seeds in the container. This signalization is supported by an interrupted acoustic signal. This acoustic signal can be turned off in the setting – during sowing fine seeds with a small batch (rape etc), see Display 2.

Picture 41– Check of the level of seeds

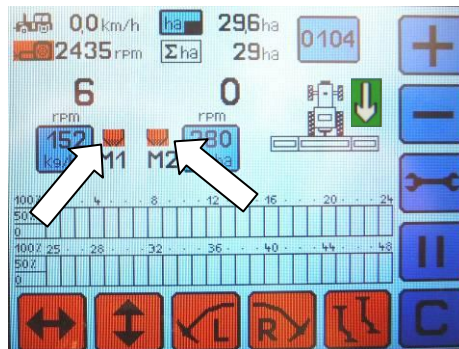

4.4.9 "Plough Turning End" Function

This function is used for sowing at the plough turning end when the field is worked in one direction. When this function is turned on, the markers are not exchanged during the lifting and lowering of the machine and the drives are not counted. If it is necessary to create a rail line during any of the drives, the plough turning end function must be turned off. Then the drive with a rail line has to be set manually (see Chapter 4.4.4/p.27). When the relevant drive is set, turn the plough turning end function on again.

4.4.10 "Presowing" function

This function is used for sowing on dissected land when it is necessary to sow into corners and sharp wedges. The function is executed in the following way: reverse the machine to the place where you want to start the drive. Lower the machine to the ground (the tractor and the machine are standing still at one place). Turn on the fan and prepare the tractor for the drive. Press the green arrow for recessing – this will automatically start sowing (the simulation of the tractor movement replacing the radar function starts) – **you must start moving in 10 seconds!** After this period the engines for sowing stop if the machine does not move.

4.5. OPERATING DISPLAY 2 – BASIC SETTING

4.5.1 Setting Minimum Fan Speed

Press the button for setting minimum fan speed and adjust the value by pressing plus or minus. A red line appears during the adjustment to indicate editing. Leave the menu by pressing the button for setting minimum fan speed again.

Picture 42 – Setting minimum fan speed

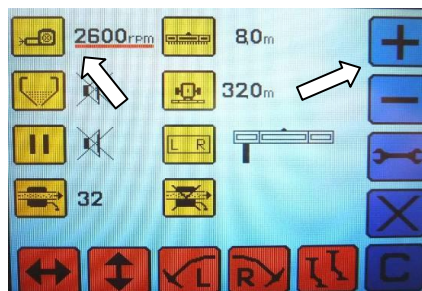

4.5.2 Setting Acoustic Signal

This signal can be set for the level of the hopper and blockage of the rail line. The signal can be set individually for each function. To turn on or off, press the button and a cross will appear on the icon of the speaker (the function is off).

Picture 43 – Setting acoustic signal

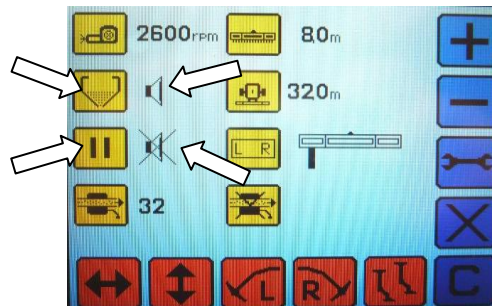

4.5.3 Setting the Number of Sensors and Change in Address

This setting is preset by the producer. It depends on the type of machine and it does not have to be adjusted during regular operation. The value is only adjusted when a sensor is replaced by a new one. Press the button for setting sensors and adjust the number by pressing plus or minus. A red line will appear below the number of the sensor to indicate editing. When you are done, press the button for setting sensors again to leave the menu.

Picture 44 – Setting acoustic signal

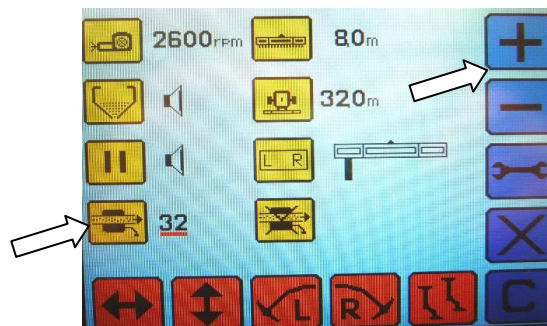

4.5.4 Replacement of the Sowing Sensor and New Sensor Number Assignment

When replacing a faulty sensor, the new sensor needs to be set with the proper number (original). Be very careful when performing this task so that you do not delete the addresses of all sensors. You must observe the following procedure:

1. Disconnect and replace the faulty sensor in the hopper
2. Connect the sensor to the connecting cable from module 2 which is under the distributor.
Make sure that only this sensor is connected!
3. Set the number on the unit by one value higher than the required number of the sensor
4. Press the button for deleting the numbers of sensors and then the button for deleting "C"
5. The module must beep after you press this button. The sensor is deleted!
6. Press the button again to leave the menu
7. Press again the button for deleting "C"
8. Disconnect the new sensor
9. Set the required number of the sensor on the button for sensor numbers and leave editing
10. Then connect the sensor – the module must beep
11. Turn off the whole electronic system
12. Disconnect the sensor
13. Connect all sensors as they were originally
14. Turn on the electronic system
15. Set the original total number of sensors
16. Leave display 2
17. Re-addressing is completed

4.5.5 Setting the Range of the Sowing Machine

This setting is already preset by the producer and it depends on the type of the machine. It is not necessary to adjust the setting during regular operation. Press the button for setting the sensors of sowing and adjust by pressing plus or minus to the required range. A red line will appear below the number to indicate editing. Leave the menu by pressing the button again.

4.5.6 Setting the Range of the Sprayer

This setting depends on the used range of the sprayer. Press the button for setting the sensors of sowing and adjust by pressing plus or minus to the required range. A red line will appear below the number to indicate editing. Leave the menu by pressing the button again.

4.5.7 Setting the Start of Sowing

This is where you set which side of the field you start sowing. Three values of the direction can be set (from the left, from the middle, from the right). Press the button for setting the start of sowing and adjust by pressing plus or minus to the required range. A red line will appear below the number to indicate the side of the start of sowing. Leave the menu by pressing the button again.

Picture 45 – Setting the start of sowing

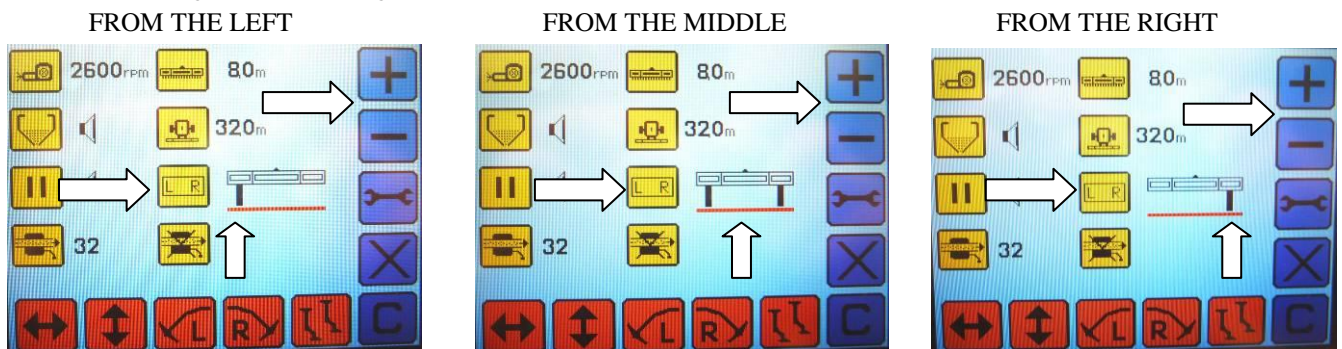

4.6. OPERATING DISPLAY 3 – TRIAL SOWING

This is where you set and calibrate the required sowing, see Chapter 6 SETTING THE SOWING.

The number of impulses is preset by the producer and it depends on the type of machine. It is not necessary to adjust this setting during regular operation.

Picture 46 – Display 3 – Trial sowing

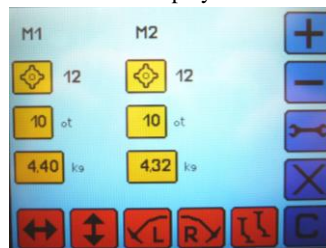

5. FILLING UP THE SEED/FERTILIZER CONTAINER



- When filling up the container, always observe safety regulations and instructions.
- The machine must be fully unfolded and must be resting on the working bodies on the ground.
- Only fill up the container on a solid and flat surface and when the machine is standing still.
- Use the access ladder for access to the service platform.
- Uncover and store the protecting canvas on the hooks located on the side of the hopper.
- Remove the central brace rod and place it on the canvas.
- Fill up the hopper with the required type and volume of seeds/fertilizer.
- Return the central brace rod back and cover the hopper with the protecting canvas.
- Push in the access ladder after you leave the service platform.
- The platform is only intended for the operator for filling up the container.
- It is strictly forbidden to use the platform during driving and operation of the machine.
- The bearing capacity of the platform is limited to **3 persons or 280kg at the most!**
- Be extra careful when moving on the platform.
- **It is strictly forbidden to transport persons or cargo on the machine!**

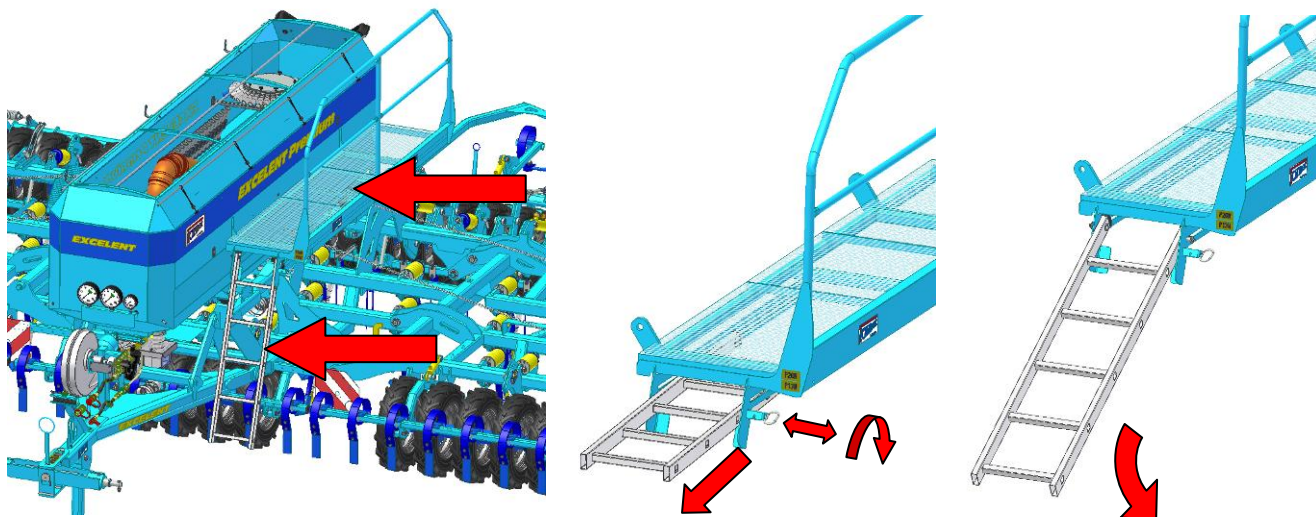

6. SELECTION OF THE SOWING BATCH

6.1. SELECTION OF THE TYPE OF SOWING

This is where you select the method of sowing (if you want to sow regular seeds or fine seeds, if you want to fertilise or not). The following diagram will show you what to do.

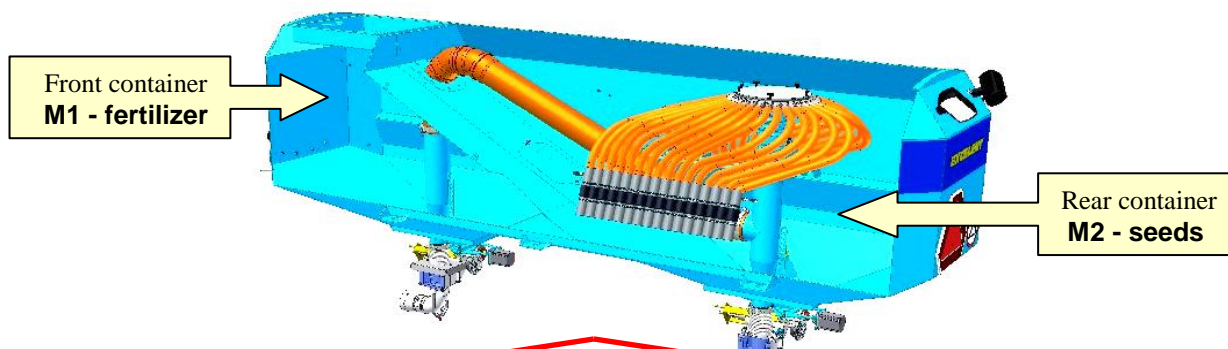

SOWING WITH FERTILISATION

SOWING WITHOUT FERTILISATION

REGULAR SEEDS

FINE SEEDS

REGULAR SEEDS

FINE SEEDS

BLUE AND GREEN TABLE

YELLOW AND GREEN TABLE

RED TABLE

YELLOW TABLE

| KALIBRAČNÍ TABULKA PRO SETI S PŘÍRODOUŠÍM (PŘÍBLIŽNÉ HODNOTY) PRO SECI STROJE EXCELENT | | | | | | | | | | | | | | | |
|---|------------------------------------|----------------|-----------------|---------------|------------------|-----------------|---------------|-----------------|---------------|-----|-----|-----|-----|-----|-----|
| OSIVO SAATGUT | PŘÍRŮČE WEEDEN | ŽITO ROGGEN | JEHEN GERSTE | OVES HAFER | FAZDLE BOHREN | HRACH ERBSEN | VKA WICKEN | KURKICE MAIS | TRÁVY GRAS | M1 | | | | | |
| Obj.hmotnost kg/dm ² | 0,77 | 0,74 | 0,68 | 0,5 | 0,85 | 0,81 | 0,83 | 0,79 | 0,36 | | | | | | |
| 15 | 20 | 20 | 20 | 30 | 30 | 30 | 30 | 18 | 17 | | | | | | |
| 20 | 30 | 30 | 30 | 40 | 40 | 40 | 40 | 27 | 25 | | | | | | |
| 30 | 50 | 50 | 50 | 60 | 60 | 60 | 60 | 45 | 40 | | | | | | |
| 40 | 70 | 70 | 70 | 80 | 80 | 80 | 80 | 63 | 57 | | | | | | |
| 50 | 100 | 100 | 100 | 120 | 120 | 120 | 120 | 90 | 80 | | | | | | |
| 60 | 130 | 130 | 130 | 160 | 160 | 160 | 160 | 126 | 112 | | | | | | |
| 70 | 170 | 170 | 170 | 210 | 210 | 210 | 210 | 171 | 151 | | | | | | |
| 80 | 210 | 210 | 210 | 280 | 280 | 280 | 280 | 225 | 198 | | | | | | |
| 90 | 260 | 260 | 260 | 360 | 360 | 360 | 360 | 297 | 264 | | | | | | |
| 100 | 300 | 300 | 300 | 480 | 480 | 480 | 480 | 378 | 336 | | | | | | |
| STUPNICE (mm) | NORMÁLNÍ OSIVO - křepka (křepka Z) | | | | | | | | | | M2 | | | | |
| | NASTAVENÍ DOZOVACÍ STĚŽNĚ M1 + M2 | | | | | | | | | | | | | | |
| | JEMNÉ OSIVO - křepka (křepka Z) | | | | | | | | | | | | | | |
| | NASTAVENÍ DOZOVACÍ STĚŽNĚ M1 | | | | | | | | | | | | | | |
| | M1 | | | | | | | | | | | | | | |
| mm | 25 | 30 | 35 | 40 | 45 | 50 | 55 | 60 | 65 | 70 | 75 | 80 | 85 | 90 | 95 |
| kg | 40 | 48 | 56 | 64 | 72 | 80 | 88 | 96 | 104 | 112 | 120 | 128 | 136 | 144 | 152 |

| KALIBRAČNÍ TABULKA VÝSEVU JEMNÉ OSIVO (PŘÍBLIŽNÉ HODNOTY) PRO SECI STROJE EXCELENT | | | | |
|---|------------------------------------|--------------------|---------------|----|
| OSIVO SAATGUT | ŘEPKA RAPS | VOJTĚŠKA ROTKLE | TRÁVY GRAS | M1 |
| Obj.hmotnost kg/dm ² | 0,65 | 0,8 | 0,36 | |
| 5 | 2 | 3 | - | |
| 7,5 | 4 | 6 | 1,7 | |
| 10 | 6 | 9 | 3 | |
| 12,5 | 8 | 11 | 5 | |
| 15 | 10 | 12 | 7 | |
| 17,5 | 12 | 15 | 9 | |
| 20 | 15 | 18 | 11 | |
| 22,5 | 17 | 21 | 13 | |
| 25 | 19 | 23 | 15 | |
| STUPNICE (mm) | NORMÁLNÍ OSIVO - křepka (křepka Z) | | | |
| | NASTAVENÍ DOZOVACÍ STĚŽNĚ M1 + M2 | | | |
| | JEMNÉ OSIVO - křepka (křepka Z) | | | |
| | NASTAVENÍ DOZOVACÍ STĚŽNĚ M1 | | | |
| | M1 | | | |
| mm | 25 | 30 | 35 | 40 |
| kg | 40 | 48 | 56 | 64 |

| KALIBRAČNÍ TABULKA PRO SETI BEZ PŘÍRODOUŠÍM (PŘÍBLIŽNÉ HODNOTY) PRO SECI STROJE EXCELENT | | | | | | | | | | | | | | | |
|---|------------------------------------|----------------|-----------------|---------------|------------------|-----------------|---------------|-----------------|---------------|---------|---------|-----|-----|-----|-----|
| OSIVO SAATGUT | PŘÍRŮČE WEEDEN | ŽITO ROGGEN | JEHEN GERSTE | OVES HAFER | FAZDLE BOHREN | HRACH ERBSEN | VKA WICKEN | KURKICE MAIS | TRÁVY GRAS | M1 + M2 | | | | | |
| Obj.hmotnost kg/dm ² | 0,77 | 0,74 | 0,68 | 0,5 | 0,85 | 0,81 | 0,83 | 0,79 | 0,36 | | | | | | |
| 15 | 20 | 20 | 20 | 30 | 30 | 30 | 30 | 18 | 17 | | | | | | |
| 20 | 30 | 30 | 30 | 40 | 40 | 40 | 40 | 27 | 25 | | | | | | |
| 30 | 50 | 50 | 50 | 60 | 60 | 60 | 60 | 45 | 40 | | | | | | |
| 40 | 70 | 70 | 70 | 80 | 80 | 80 | 80 | 63 | 57 | | | | | | |
| 50 | 100 | 100 | 100 | 120 | 120 | 120 | 120 | 90 | 80 | | | | | | |
| 60 | 130 | 130 | 130 | 160 | 160 | 160 | 160 | 126 | 112 | | | | | | |
| 70 | 170 | 170 | 170 | 210 | 210 | 210 | 210 | 171 | 151 | | | | | | |
| 80 | 210 | 210 | 210 | 280 | 280 | 280 | 280 | 225 | 198 | | | | | | |
| 90 | 260 | 260 | 260 | 360 | 360 | 360 | 360 | 297 | 264 | | | | | | |
| 100 | 300 | 300 | 300 | 480 | 480 | 480 | 480 | 378 | 336 | | | | | | |
| STUPNICE (mm) | NORMÁLNÍ OSIVO - křepka (křepka Z) | | | | | | | | | | M1 + M2 | | | | |
| | NASTAVENÍ DOZOVACÍ STĚŽNĚ M1 + M2 | | | | | | | | | | | | | | |
| | JEMNÉ OSIVO - křepka (křepka Z) | | | | | | | | | | | | | | |
| | NASTAVENÍ DOZOVACÍ STĚŽNĚ M1 + M2 | | | | | | | | | | | | | | |
| | M1 + M2 | | | | | | | | | | | | | | |
| mm | 25 | 30 | 35 | 40 | 45 | 50 | 55 | 60 | 65 | 70 | 75 | 80 | 85 | 90 | 95 |
| kg | 40 | 48 | 56 | 64 | 72 | 80 | 88 | 96 | 104 | 112 | 120 | 128 | 136 | 144 | 152 |

| KALIBRAČNÍ TABULKA VÝSEVU JEMNÉ OSIVO (PŘÍBLIŽNÉ HODNOTY) PRO SECI STROJE EXCELENT | | | | |
|---|------------------------------------|--------------------|---------------|---------|
| OSIVO SAATGUT | ŘEPKA RAPS | VOJTĚŠKA ROTKLE | TRÁVY GRAS | M1 + M2 |
| Obj.hmotnost kg/dm ² | 0,65 | 0,8 | 0,36 | |
| 5 | 2 | 3 | - | |
| 7,5 | 4 | 6 | 1,7 | |
| 10 | 6 | 9 | 3 | |
| 12,5 | 8 | 11 | 5 | |
| 15 | 10 | 12 | 7 | |
| 17,5 | 12 | 15 | 9 | |
| 20 | 15 | 18 | 11 | |
| 22,5 | 17 | 21 | 13 | |
| 25 | 19 | 23 | 15 | |
| STUPNICE (mm) | NORMÁLNÍ OSIVO - křepka (křepka Z) | | | |
| | NASTAVENÍ DOZOVACÍ STĚŽNĚ M1 + M2 | | | |
| | JEMNÉ OSIVO - křepka (křepka Z) | | | |
| | NASTAVENÍ DOZOVACÍ STĚŽNĚ M1 + M2 | | | |
| | M1 + M2 | | | |
| mm | 25 | 30 | 35 | 40 |
| kg | 40 | 48 | 56 | 64 |

SETTING THE AIR PRESSURE
+ TRAVEL SPEED

ATTENTION!!! When sowing with fertilizer, set the required dose according to the blue-and-green calibration table for each sowing mechanism. When sowing without fertilizer, set the value for each sowing mechanism according to the red calibration table. The sum of both mechanisms then gives the final dose.

6.2. SOWING TABLES

Tab. 8 – Sowing table for regular seeds and sowing with fertilisation

| CALIBRATION TABLES FOR SOWING WITH FERTILIZER (APPROXIMATE VALUES) FOR THE EXCELENT SOWING MACHINES | | | | | | | | | | | | | | | |
|---|--------------|---|--------|------|-------|------|-------|-------|------------|-----|-----|-----|-----|-----|-----|
| SEEDS Vol. mass kg/dm ³ | WHEAT | RYE | BARLEY | OATS | BEANS | PEAS | VETCH | MAIZE | GRAMINOIDS | | | | | | |
| | 0,77 | 0,74 | 0,68 | 0,5 | 0,85 | 0,81 | 0,83 | 0,79 | 0,36 | | | | | | |
| M2 | | REGULAR SEEDS - kg/ha (flap A) FEEDER SETTING M2 | | | | | | | | M2 | | | | | |
| SCALE (mm) | 15 | - | 20 | 20 | - | 30 | 20 | 30 | 15 | 17 | | | | | |
| | 20 | 30 | 30 | 30 | 20 | 40 | 40 | 50 | 25 | 25 | | | | | |
| | 30 | 55 | 52 | 50 | 38 | 75 | 75 | 85 | 67 | 40 | | | | | |
| | 40 | 75 | 72 | 70 | 52 | 110 | 115 | 122 | 110 | 60 | | | | | |
| | 50 | 100 | 95 | 90 | 65 | 148 | 150 | 158 | 150 | - | | | | | |
| | 60 | 120 | 115 | 110 | 80 | 183 | 185 | 195 | 185 | - | | | | | |
| | 70 | 142 | 135 | 130 | 100 | 217 | 220 | 230 | 220 | - | | | | | |
| | 80 | 165 | 160 | 150 | 110 | 255 | 260 | 268 | 255 | - | | | | | |
| | 90 | 185 | 180 | 170 | 125 | 290 | 295 | 305 | 291 | - | | | | | |
| | 100 | 210 | 210 | 200 | 150 | 324 | 330 | 340 | 328 | - | | | | | |
| 110 | 290 | 295 | 280 | 200 | 359 | 370 | 377 | 365 | - | | | | | | |
| M1 | | FERTILIZER - kg/ha (flap A) FEEDER SETTING M1 | | | | | | | | M1 | | | | | |
| mm | SCALE (mm) | | | | | | | | | | | | | | |
| | 25 | 30 | 35 | 40 | 45 | 50 | 55 | 60 | 65 | 70 | 75 | 80 | 85 | 90 | 95 |
| kg | 40 | 65 | 80 | 85 | 100 | 115 | 125 | 130 | 145 | 155 | 170 | 195 | 210 | 230 | 250 |

Tab. 8a – Sowing table for regular seeds and sowing without fertilisation

| CALIBRATION TABLES FOR SOWING WITHOUT FERTILIZER (APPROXIMATE VALUES) FOR THE EXCELENT SOWING MACHINES | | | | | | | | | | |
|--|-------|---|--------|------|-------|------|-------|-------|------------|----|
| SEEDS Vol. mass kg/dm ³ | WHEAT | RYE | BARLEY | OATS | BEANS | PEAS | VETCH | MAIZE | GRAMINOIDS | |
| | 0,77 | 0,74 | 0,68 | 0,5 | 0,85 | 0,81 | 0,83 | 0,79 | 0,36 | |
| M1 + M2 | | REGULAR SEEDS - kg/ha (flap A) SETTING BOTH FEEDERS WITH THE SAME VALUES M1 + M2 | | | | | | | M1 + M2 | |
| SCALE (mm) | 10 | 40 | 35 | 25 | 16 | 13 | 13 | 26 | 8 | 15 |
| | 15 | 50 | 45 | 40 | 32 | 39 | 25 | 40 | 20 | 22 |
| | 20 | 65 | 60 | 65 | 45 | 52 | 52 | 65 | 32 | 32 |
| | 30 | 105 | 100 | 100 | 75 | 98 | 98 | 110 | 87 | 52 |
| | 40 | 150 | 140 | 140 | 105 | 143 | 150 | 158 | 145 | 78 |
| | 50 | 195 | 185 | 175 | 130 | 192 | 195 | 205 | 195 | - |
| | 60 | 235 | 220 | 215 | 160 | 235 | 240 | 255 | 240 | - |
| | 70 | 280 | 270 | 260 | 205 | 280 | 285 | 300 | 285 | - |
| | 80 | 320 | 315 | 295 | 220 | 330 | 335 | 345 | 330 | - |
| | 90 | 370 | 350 | 330 | 250 | 370 | 380 | 395 | 375 | - |
| 100 | 400 | 395 | 375 | 280 | - | - | - | - | - | |

Tab.9 - Sowing table for fine seeds

| CALIBRATION TABLE FOR SOWING FINE SEEDS (APPROXIMATE VALUES) FOR THE EXCELENT SOWING MACHINES | | | | |
|---|-------|---------|------------|-----|
| SEEDS Vol. mass kg/dm ³ | SWEDE | LUCERNE | GRAMINOIDS | |
| | 0,65 | 0,8 | 0,36 | |
| REGULAR SEEDS - kg/ha (flap Z) | | | | |
| SCALE (mm) | 5 | 2 | 3 | - |
| | 7,5 | 4 | 6 | 1,7 |
| | 10 | 6 | 9 | 3 |
| | 12,5 | 8 | 11 | 5 |
| | 15 | 10 | 12 | 7 |
| | 17,5 | 12 | 15 | 9 |
| | 20 | 15 | 18 | 11 |
| | 22,5 | 17 | 21 | 13 |
| | 25 | 19 | 23 | 15 |

Always set the value according to the relevant sowing table for the given seeds. For instance, when you want to sow 170kg/ha of barley without fertilizing, set the value on the turnstile scale according to the red table to 45. The selected quantity of seeds that you want to sow on 1ha is set on the sowing mechanism, Picture 47.

When fertilizing during fine seeds sowing, you can turn the feeding of the container. This means that you can place fine seeds in front container **M1** and fertilizer in rear container **M2**.

Picture 47 – Setting on the turnstile

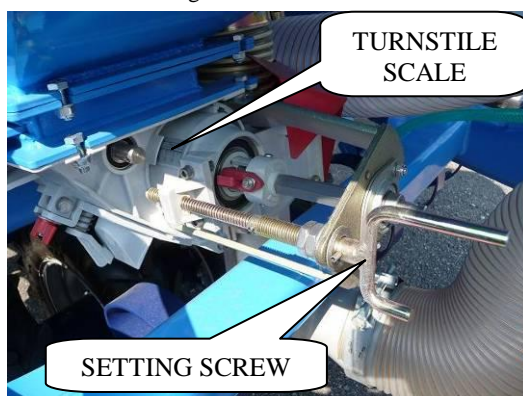

6.3. PROCEDURE FOR EXECUTING A TRIAL SOWING



Only use the antiskid steps to access the places for adjusting the turnstile – see Picture 50. Never step on any other parts of the machine, in particular the tyres: there is a danger of injury. The steps are only intended for the operator for setting the turnstile. It is strictly forbidden to move on the steps during driving and operation of the machine. Always be extra careful when moving on the access steps.

Picture 49 – Scales with the bag



Picture 50 – Access steps of the rear sowing mechanism

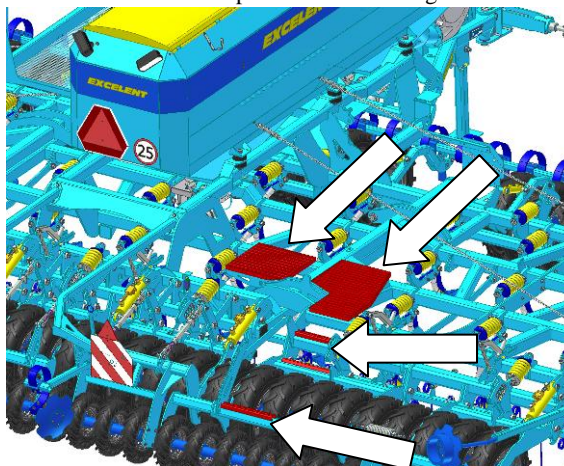

6.3.1 Setting the testing scales

Before hanging up the bag, the trial scale has to be turned on and set to correct units (kg). Execute the setting by pressing the "UNIT" button and the set units are shown by the arrow in the lower right corner of the scale display. "Kg" units are at the bottom, see the picture.

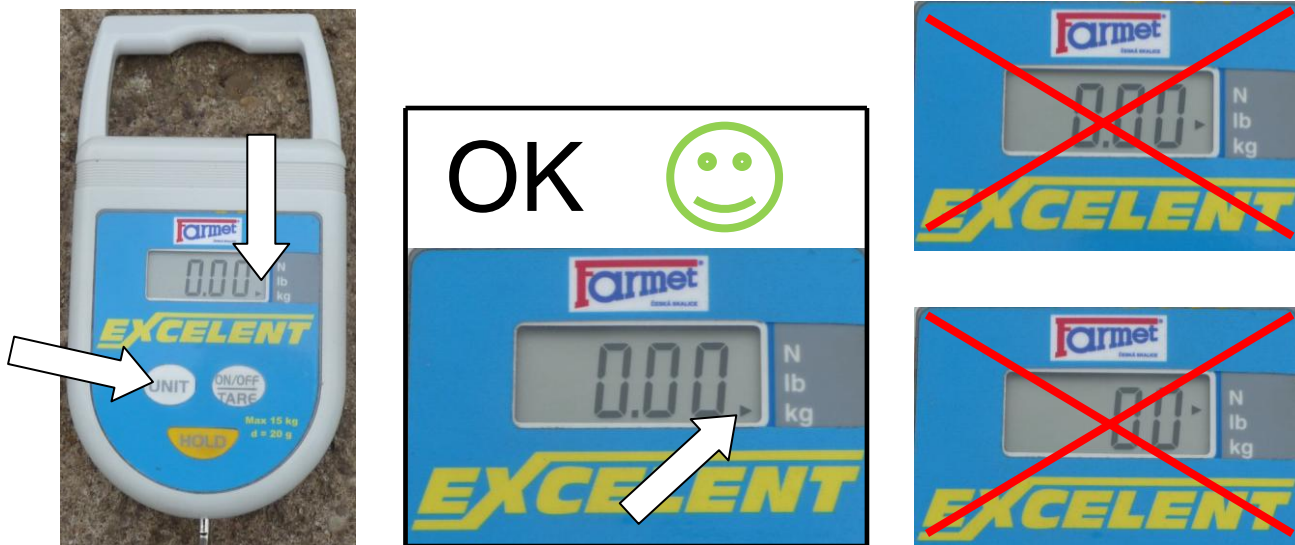

When the scale is turned on again, it shows the set units. When the units have been set, place the scale to the designated place on the hopper and hang an empty calibration bag on the scale. Perform tare (set the scales to zero with the attached bag). The tare is performed by pressing and holding the button "TARE". Then you can perform the trial sowing. Be careful as the scales will turn off automatically after five minutes of inactivity and the tare is not saved so you have to do it all over again.

6.3.2 Opening the turnstile and hanging up the bag

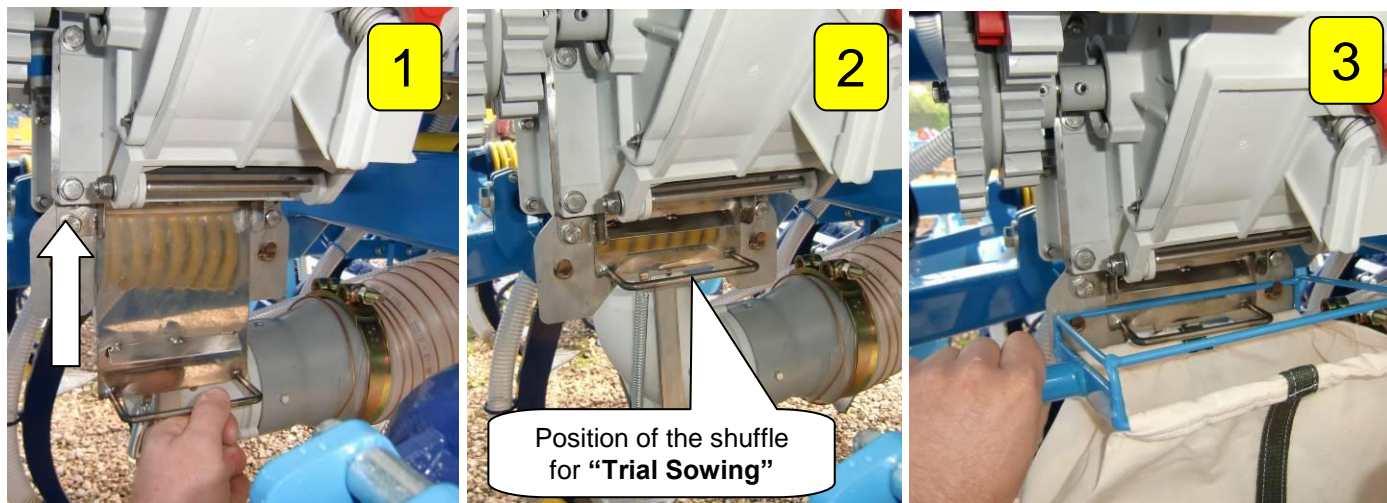

Firstly, place the shuffle in the turnstile to the position "TRIAL SOWING" and then hang up the calibration bag. When you hang the bag, you have to set the speed of the trial sowing of the relevant engine to zero. Press the button for engine speed and set it to zero by pressing "C". A red line will appear below the number to indicate editing. Leave the menu by pressing the button again.

Picture 51– Setting the speed to zero

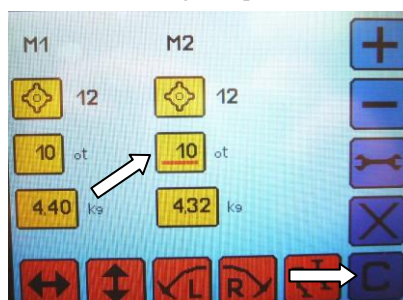

When you set the speed to zero, execute trial sowing for the relevant turnstile by pressing the red button on the turnstile engine picture 52 and holding it until the bag has filled up by about 1/2. Generally, the larger the sowing is, the more exact the trial is. When you release the button, the number of used revolutions will appear on the display. Do not adjust this value.

Picture 52 – Button for the engine



When pressing the engine button, do not put your fingers or approach the gearing of the turnstile – there is a danger of injury.

When the bag is full, take it off the diffuser and weigh it. Enter the result into the unit. Press the button for the weight of trial sowing and adjust by pressing plus or minus to the required range. A red line will appear below the number to indicate editing. Leave the menu by pressing the button again.

For faster editing, it is possible to press the button for the key after pressing plus or minus and the weight will be adjusted automatically. You can stop the adjustment by pressing plus or minus again.

Picture 53 – Entering the weight

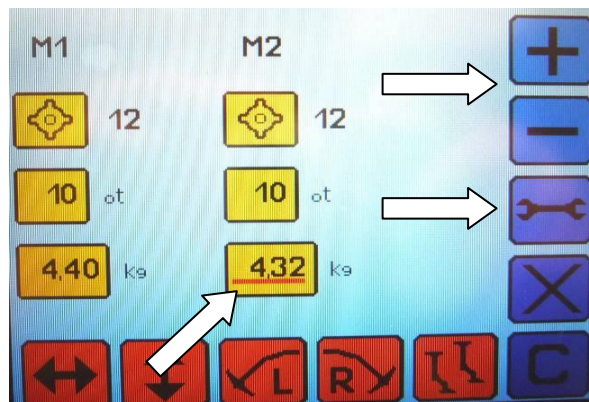

Perform the aforementioned for both sowing mechanisms separately. When you finish the weighing and entering data into the unit, leave display 3 by pressing down the button with the cross. Finish the calibration of the sowing batch on the main display. Press the button for setting the batch and adjust by pressing plus or minus to the required range. A red line will appear below the number to indicate editing. Leave the menu by pressing the button again. The sowing batch is now set.

Picture 54 – Adjustment of the sowing

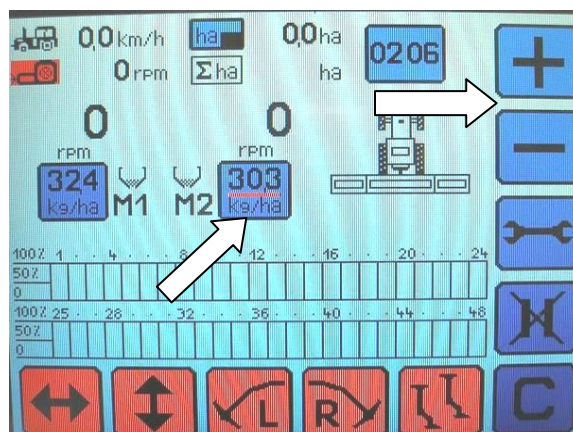

When you open display 3 and then go back to the basic display, the sowing batch will be recalculated according to the weighed value and turnstile revolutions. Therefore you have to adjust the required value.

After the completion of the trial sowing, return the shuffle back to the position “SOWING”.

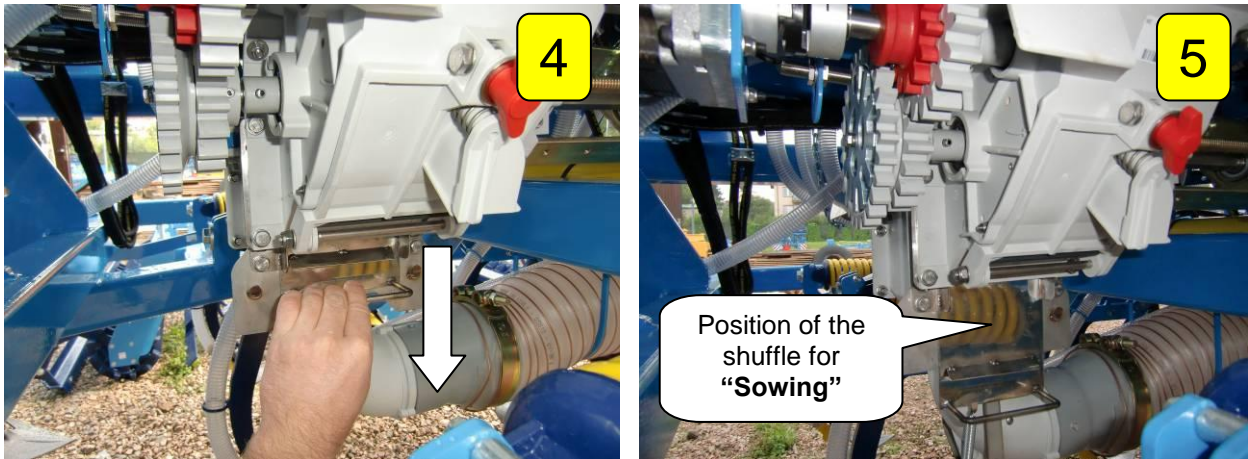

6.4. SETTING THE FINE SEEDS SOWING

The minimum setting of the turnstile for fine seeds is 6 mm. Lower setting may cause inaccuracies in seed feeding.

For fine seeds, set the setting roller to position 0 – the container must be closed beforehand and the seeding mechanism must be empty. Place the closing valve on the body of the feeder into the cut on the hexagon shaft. This way the roller of the feeder can move only within the range from 0 to 25 mm.

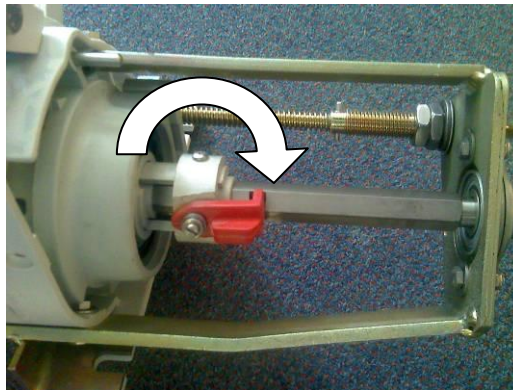

Do not change the setting of the red toothed wheel as it has to stay in the same position (pushed in) for sowing of all crops!!!

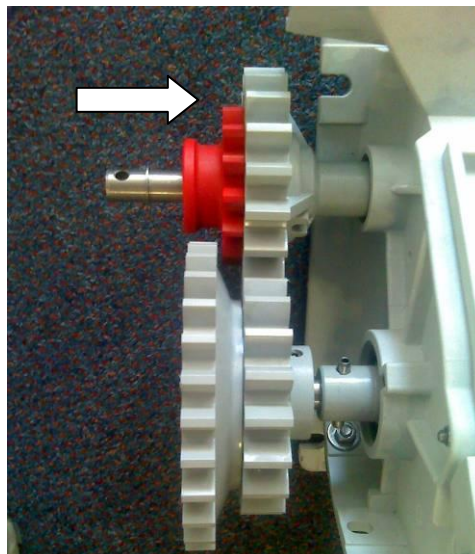

If you want to create rail lines when sowing fine seeds with fertilizer, you need to turn the filling of the hopper. That means that you place fertilizer into the rear container (M2) and seeds into the front container (M1). The air pressure setting remains the same as in Chapter 6.4.

Proceed as in described in Chapter 6.2.

6.5. SELECTION OF THE SOWING RANGE AND FERTILISER ACCORDING TO SPEED

The volume of the sowing batch depends on the travel speed, the amount of fertiliser and air pressure in the sowing mechanisms as shown in the graph. The air pressure in the front mechanism must be always lower by 1 kPa than in the rear. Use the choke valve on the front sowing mechanism for regulation.

Tab. 10 – Setting the air, maximal seed batch and working speed

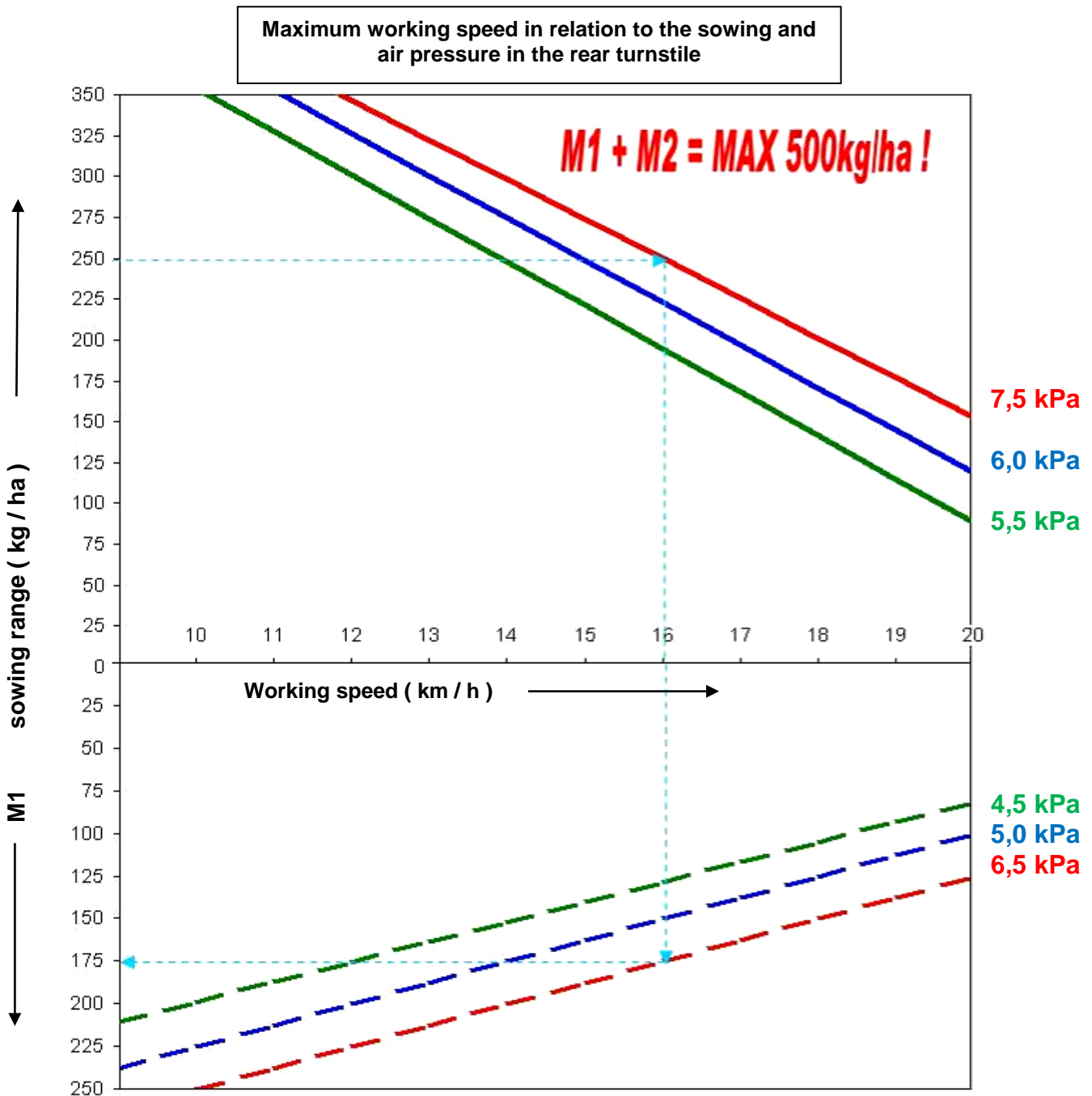

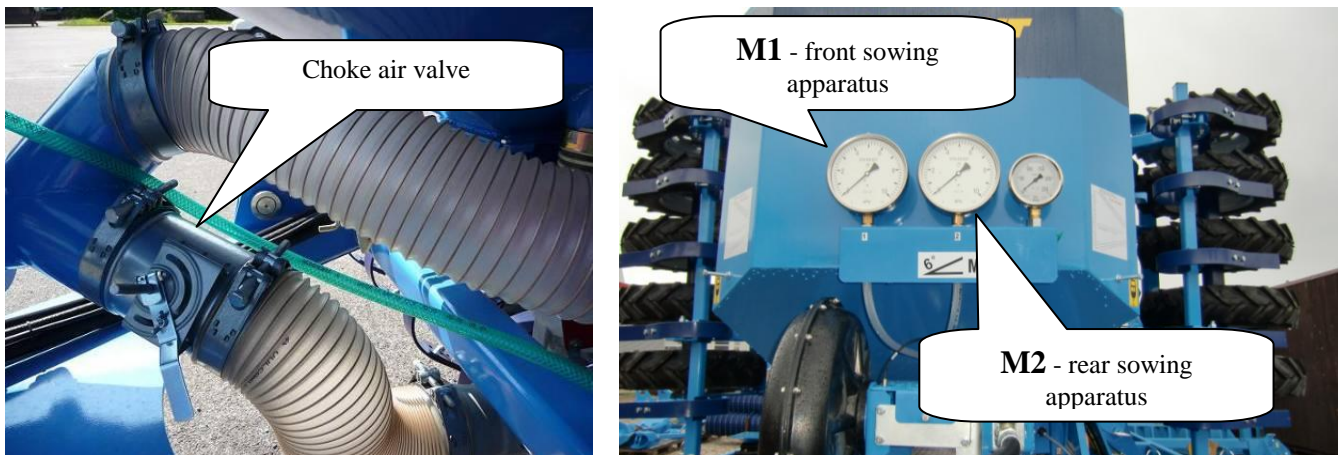

7. ADJUSTMENT OF THE WORKING PARTS OF THE MACHINE

Picture 55 – Diagram of the working parts

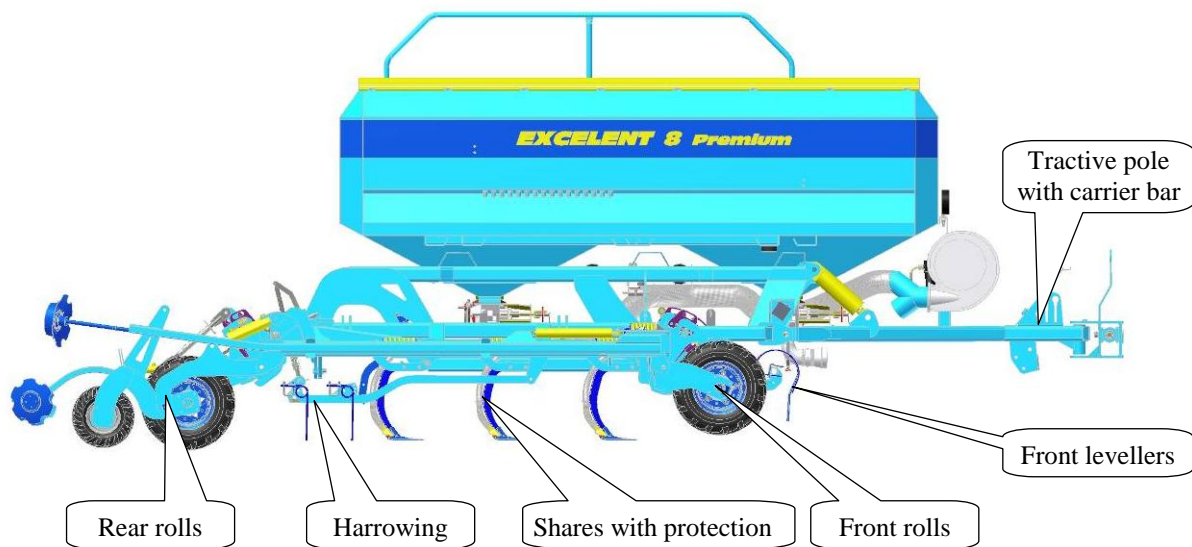

7.1. ADJUSTMENT OF THE WORKING DEPTH OF THE MACHINE

- 7.1.1 By TPM arms of the tractor
- 7.1.2 By gates of the front pneumatic rolls
- 7.1.3 By gates of the rear pneumatic rolls

Tab. 11 – Sowing depths

| Table of approximate sowing depths of EXCELENT Premium 6; 8* | | Table of recommended sowing depths of selected farming products | |
|--|--------------------------|---|-------------------------------|
| Setting the depth | Approximate depth (mm) * | Farming product | Recommended sowing depth (mm) |
| -3 | -20 | WHEAT | 30 - 50 |
| -2 | -10 | RYE | 30 - 50 |
| -1 | 0 | BARLEY | 30 - 50 |
| 0 | 10 | OATS | 30 - 50 |
| 1 | 20 | BEANS | 30 - 60 |
| 2 | 30 | PEAS | 30 - 60 |
| 3 | 40 | LUPINE | 30 - 60 |
| 4 | 50 | VETCH | 30 - 60 |
| 5 | 60 | MAIZE | 30 - 60 |
| 6 | 70 | SWEDE | 20 - 30 |
| 7 | 80 | LUCERNE | 10 - 20 |
| | | GRAMINOIDS | 10 - 20 |



* The number of the set working depth is for information only and it may be influenced by the soil structure and properties. The depth should always be tested on the actual field before sowing and the actual depth of depositing seeds in the soil has to be checked!!!

There is a threat of imbalance and irregularities of growth when the sowing depth is not sufficient and there is subsequent drought!!!

The use of trail cultivators is recommended to eliminate compaction in the place of the tractor wheel tracks.

7.1.1 Adjusting the Machine by TPM Arms of the Tractor

Set the machine so that it is on the same level as the ground with the use of TPM arms of the tractor. This will ensure the same depth of soil processing in the front and rear of the machine.

Picture 56 – TPM adjustment

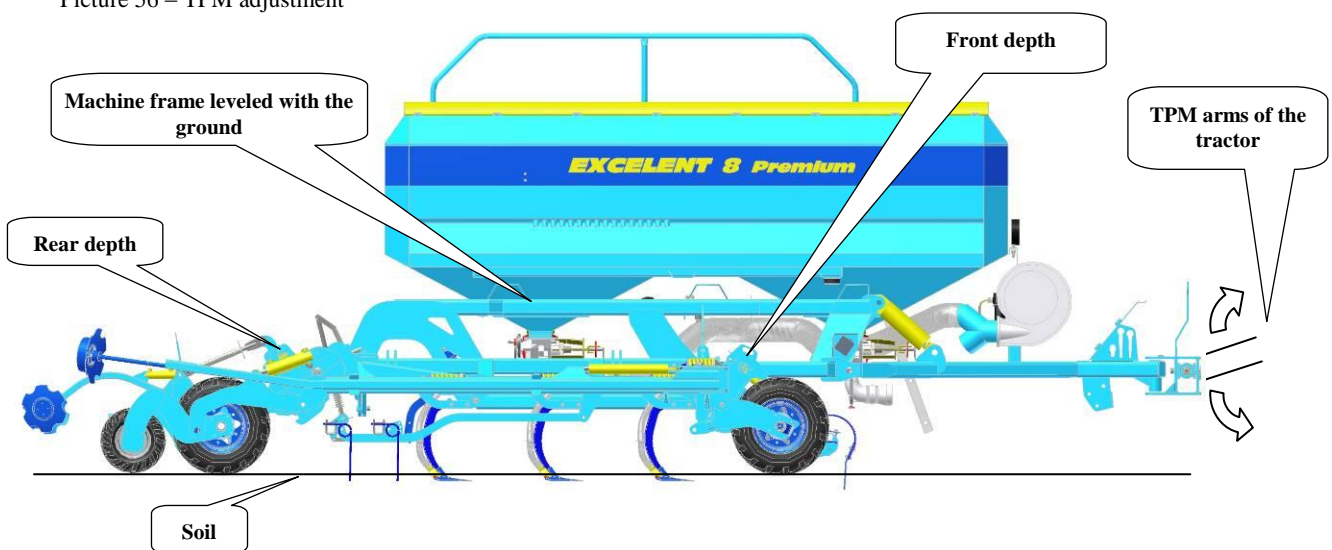

Attention! Set the arms of the tractor to such height so that the springs of the machine frame are not pressed as it could cause malfunction of the mechanism. See Picture 57.

Picture 57 – Mechanism of roll springing

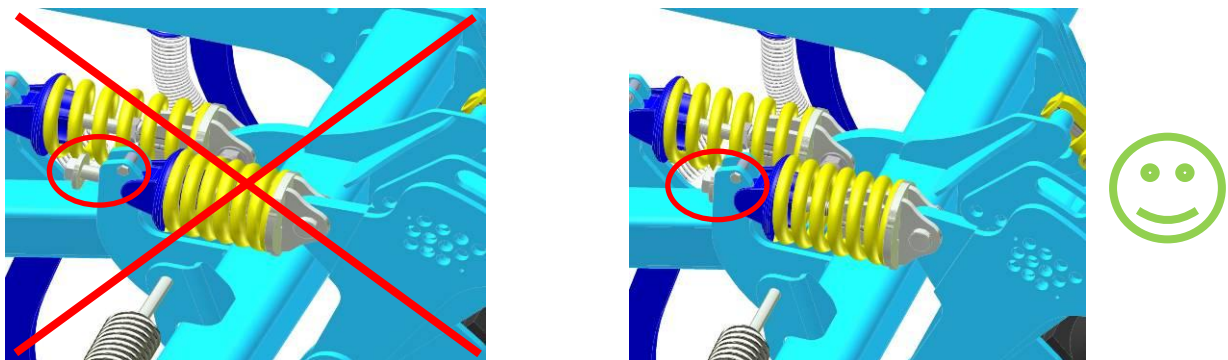

7.1.2 Adjusting the Gates of Pneumatic Rolls

The setting of the sowing depth is executed with the use of a pin which is set in the holes of the setting plate by shifting the stop board. One opening corresponds with the given setting according to the setting plate in the stop board.

In order to make the depth setting functional, all setting plates must be set to the same value, i.e. in the same opening of the plate!!!

Picture 58 – Setting the depth

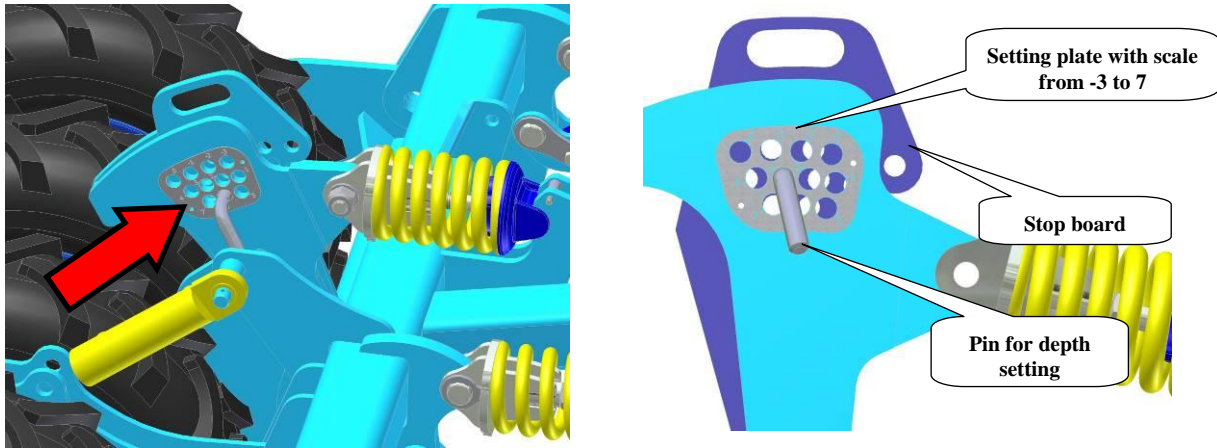

Openings in the stop boards.

Picture 59 – Openings in the stop boards
FRONT

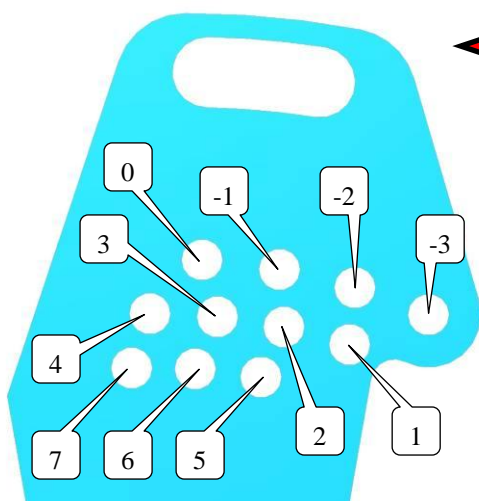

REAR

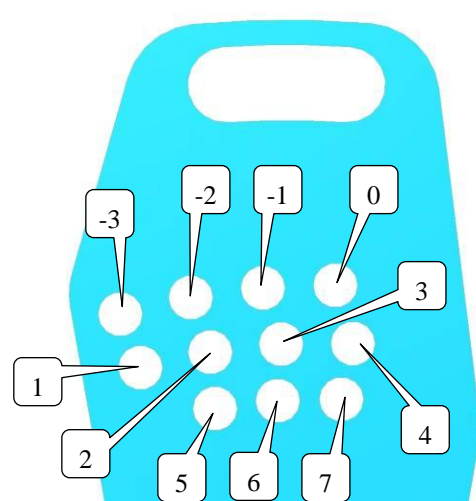

7.1.3 Adjusting Front Land Levellers

The height of the levellers is set hydraulically from the tractor cabin. The angle setting is executed with the use of the screw. Its position is changed in the holes of the setting plate.

Picture 60 – Setting the levellers

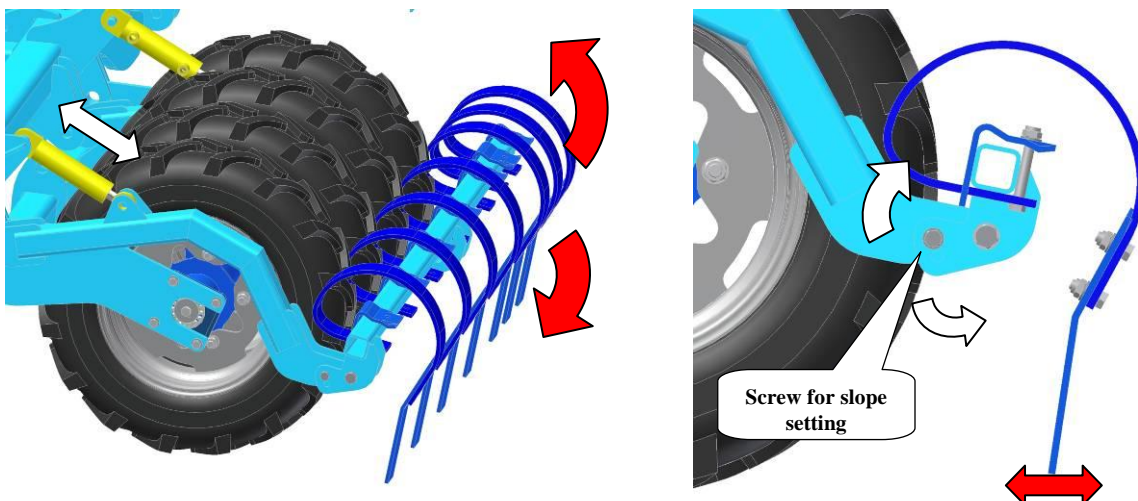

7.1.4 Adjusting the Harrowing

The height setting of harrowing is performed with the use of the handle. The angle setting is executed by the pin. Its position is changed in the holes of the setting plate.

Picture 61 – Setting the harrowing

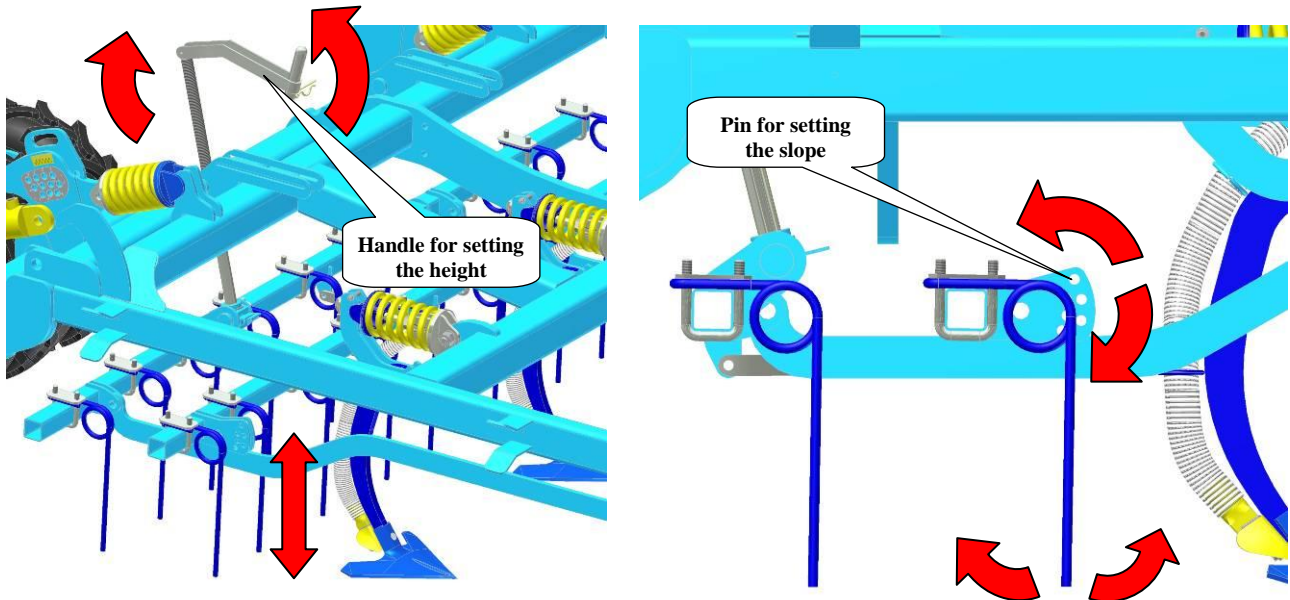

7.2. SHARE PROTECTION

- The basic setting of the supporting spring is set by the producer to 184 ± 2 mm so that it is horizontal.
- Check regularly that the nuts of the bottom and upper stopper are tight, if not, tighten them.
- Check regularly that the nuts of the supporting screw inside the spring are tight.

Picture 62 – Share protection

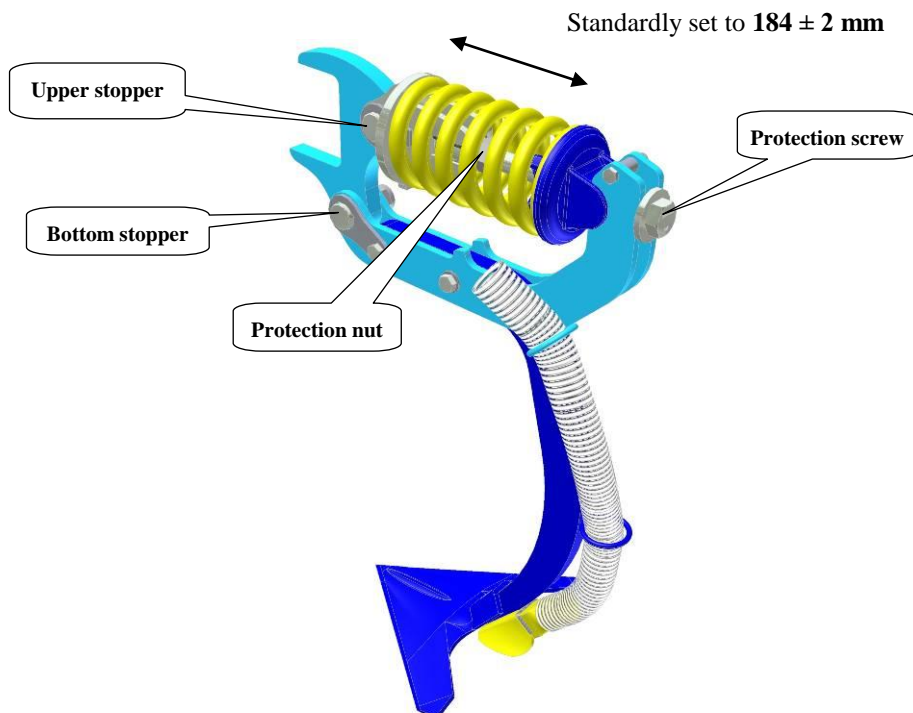

7.3. CALIBRATION THE MACHINE PLANE

- The basic machine plane is preset by the producer.
- Check this plane regularly once during the season, after you replace all the shares.
- The check must be performed on a flat and solid surface with bumps up to 1 cm.

- Plane calibration:
1. Place the machine on a flat and solid surface
 2. Unfold the machine into the working position
 3. Lift the front levellers and harrowing to the highest position so that they do not touch the pad when placed on the pad
 4. Set the depth setting plates to "0"
 5. Lower the machine to the ground so that shares are sitting on the ground
 6. Turn the screw for the machine springing (clockwise) so that a gap is created between the stop board and the stop position of the pneumatic roll frame
 7. Then turn the screw for the machine springing (anti-clockwise) so that the stop board is leaning against the stop of the pneumatic roll and stop turning at the moment when the shares start to lift from the pad.
 8. Set all 13 pieces of springing in the machine in the this way

Picture 63 – Plane of the machine

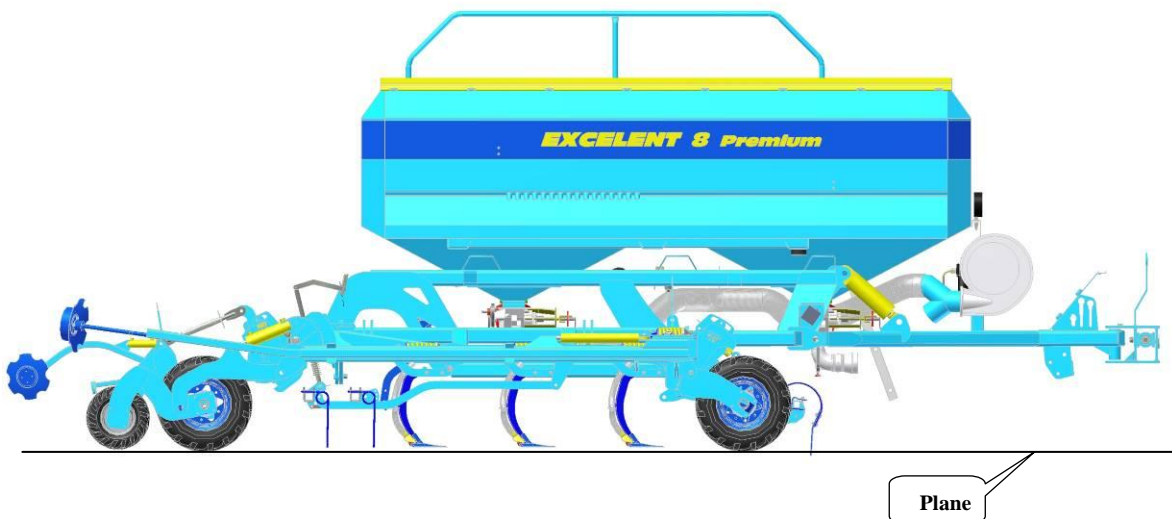

Picture 64 – Setting the plane of the machine

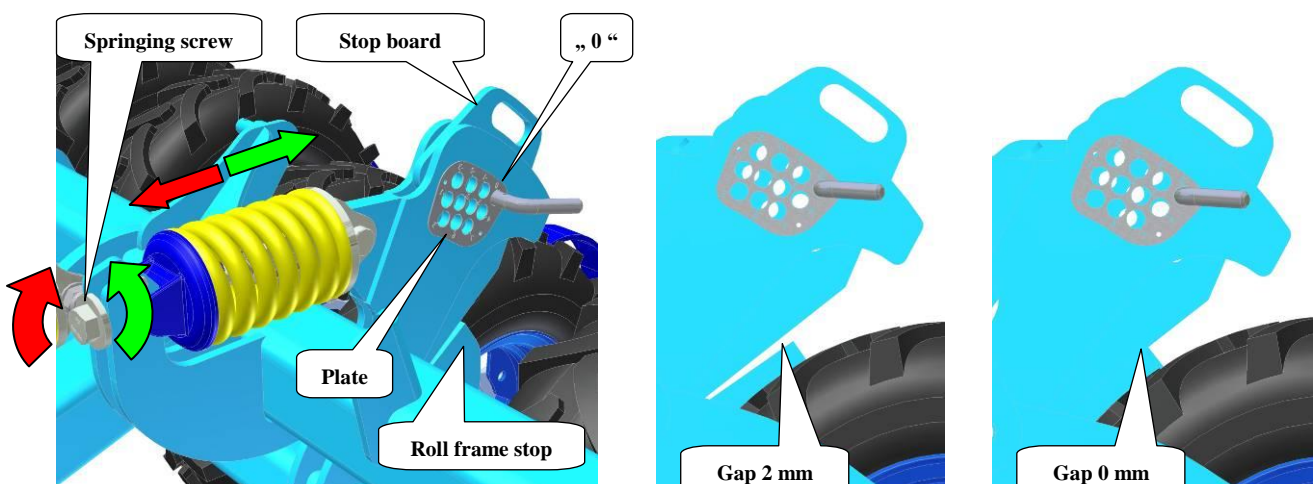

7.4. MAKERS

Markers can only be set to the centre of the tractor, they copy the terrain. Each marker can be manipulated individually and they can be lowered hydraulically. The speed of opening a marker is regulated by choke valves. One rule applies that you should always choke the flow of oil returning from the piston-rods of the markers. Set the choke valves as needed and observe all instructions of safety at work.

The guarantee will not be accepted if there has been an unauthorized intervention in the system. In case of any defects in the system, contact the Service Department of the production plant.

The distance of the marker disc range is from the frame of the outermost share. Always test in practice on the field.

Picture 65 - Setting of the markers

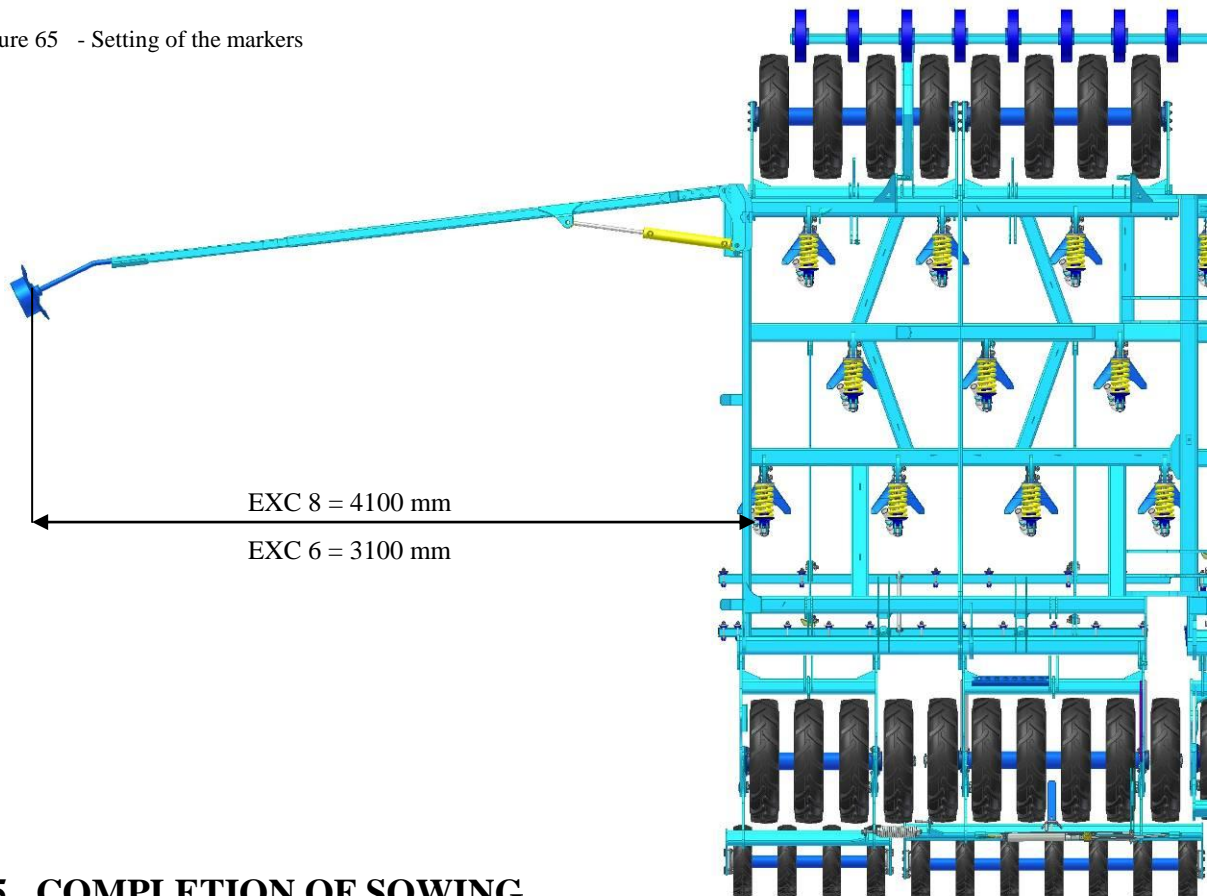

7.5. COMPLETION OF SOWING

If there are still seeds in Container 1 after the end of sowing, place a container under the lid in Container 2 (see Picture 66) and release lid 3. If you do not pour the seeds onto a grid (in large capacity hoppers) but into sacks (in large capacity hoppers) but into sacks and if there is still quite a lot of seeds in the hopper, empty the hopper with the use of the separator on the lid 3. The separator allows stopping the flow of seeds from the hopper when needed.

Picture 66 – Detail of emptying the container

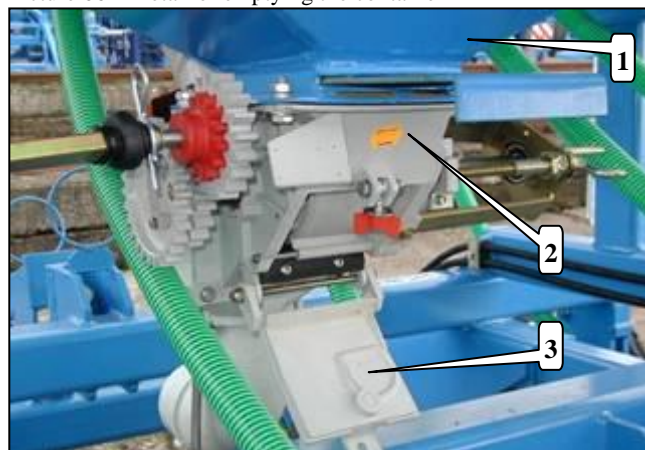

When you empty the container, we recommend “sowing” a few metres with the empty machine and running fan in order to remove the residues of seeds from the feeder and the whole system of the machine.

Prompt removal of the seed residues, especially when you do not use the machine for a longer period of time, prolongs its usable life and prevents complications in the following operation.

8. SUMMARY OF TASKS BEFORE THE COMMENCEMENT OF WORK

- **Aggregate** the machine with the tractive equipment according to the instructions in Chap.3/str.12
- **Connect the hydraulics and electronics** of the sowing machine with the tractor
- **Turn on the display unit** and unfold the machine
- **Adjust the plane of the machine** – set the lower stop of the tractor three-point mounting, all hatches of the rubber-tyred wheels must be set to the same height
- **Set the required data on the second display** – swathe of the sprayer, start of sowing, acoustic signals
- **Set the necessary sowing sample** – set the value on the turnstile according to the chart, turn on the third display, fill up the sowing mechanism, set the number of M1 engine revs to zero, perform a trial sowing, enter the value of the weighed sample, set the number of M2 engine revs to zero, perform a trial sowing, enter the value of the weighed sample, switch to the basic display and execute sowing calibration
- **Set the priority** to the hydraulic circuit to which the hydraulic motor of the fan is connected
- Set the air pressure to the value of **6-8 kPa** – by regulating the oil flow in the tractor
- Pressurize the down pressure in the side frames – to the value of **30 bar EXC 6 (50 bar EXC 8)**
- Set the required **hydraulic functions** – markers, marking rail lines etc.
- Lower the front part of the machine by the tractor three-point mounting **during the drive**
- After that lower the rear part of the machine – when the machine is completely recessed, let the hydraulic circuit run under pressure for 5-7 seconds and then set it to the **floating position!!!!**
- **Maximal working speed** according to the graph: sowing sample x speed x air pressure
- When starting sowing in the corner of the land or when sowing the wedges, use the **presowing** function – press the green arrow depicting the recess of the machine – this automatically starts the sowing (the simulation of the tractor motion will start, which will replace the radar function) – **the machine must start moving in 10 seconds!!!!!!**

9. MAINTENANCE AND REPAIRS OF THE MACHINE



Observe the safety instructions for maintenance and treatment.

- Only persons according to Chapter A.3/p. 6 may perform repairs of the machine. When leaving the tractor cabin, the operator must switch off all hydraulic circuits and appliances on the machine (ventilator) and the engine and the operator must prevent unauthorized access to the tractor.
- The replacement of worn shares can only be executed when the machine is standing still (not operating).
- If you have to use welding during a repair and have the machine connected to the tractor, make sure that all supply cables are disconnected from the alternator and accumulator.
- Check that all screws and other assembly points are tight before each use of the machine and whenever needed.
- Regularly check the wear and tear of the working parts of the machine or replace the worn working parts with new ones.
- Adjusting, cleaning and lubricating the machine may only be performed when the machine is standing still (the machine is stopped and is not working).
- When the machine is lifted, use an appropriate supporting device propped at designated places or at appropriate places.
- When adjusting, cleaning, maintaining and repairing the machine, secure those parts of the machine that could put the operator in danger by fall or other movement.

- Repairs of the hydraulic circuits may be performed only when the machine is unfolded and resting on the working bodies on the ground.
- When repairing the hydraulic circuits of the machine, first remove pressure from the hydraulic circuits of the machine with the use of control levers of the hydraulic system in the tractor cabin.
- For attaching the machine when manipulating it with the use of lifting equipment, use only places marked by stick-on labels with the symbol of a chain „“.
- If there is a defect or damage on the machine, immediately turn off the tractor engine and secure the engine from turning on, secure the machine against movement ⇒ then you can remove the defect.
- When repairing the machine, use only original spare parts, suitable tools and protective equipment.
- Check the prescribed pressure in the tyres of the machine and the condition of the tyres regularly. Execute potential repairs of tyres in a professional workshop.
- Keep the machine clean.



Do not use a high-pressure cleaner or direct water jet for cleaning hydraulic rolls (piston rod) and bearings and electronic parts. The bearings and seals are not waterproof under high pressure.



9.1. REPLACEMENT OF WORN SHARES

- When replacing shares, always observe safety regulations and instructions.
- The machine must be aggregated with a tractor according to Chapter 3.1/p. 12 during the replacement of shares. The tractor engine must be switched off during the replacement of shares and the operator or mechanic must prevent unauthorized access to the tractor.
- The machine must be raised on the transportation axle and the tractor shoulders during the replacement of shares.
- Raise the rear tractor TBZ shoulders with the aggregated machine to the maximal position and secure it from falling. Then you may perform the replacement of worn shares
- The ball valve of the axle must be in the “closed” position, see Picture .18/str.17. You must ensure mechanical supports under the pole of the machine in case the tractor hydraulic system is not tight.
- Only replace shares when the machine is unfolded and resting on the working bodies on the ground.

9.2. LUBRICATION PLAN FOR THE MACHINE

Tab. 12

| LUBRICATION POSITION | | INTERVAL | LUBRICANT |
|---|---------------|---------------|--|
| Pole joint | Picture 67 | 1 x week * | Plastic lubricant K EP2 - 30 DIN 51 502 |
| Stoppers of folding joints of the side frames | Picture 68 | 1 x week * | |
| Bearings | Picture 69,70 | after 100 ha* | |
| Bearings of axle | Picture 71 | every day * | |
| Handle for setting the harrowing | Picture 72 | 1 x week * | |

*- Applies to the period when the machine is used on the field.

Picture 67 – Pole joint

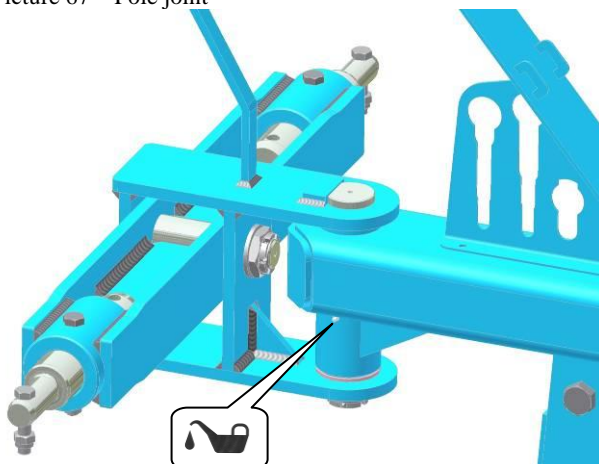

Picture 68 – joints

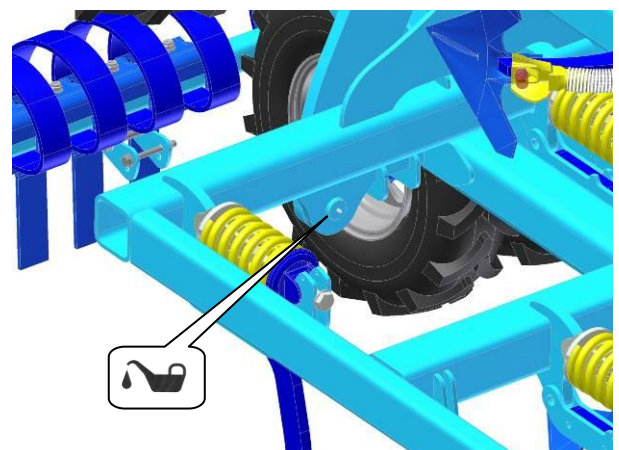

Picture 69 – Roll bearings



Picture 70 – Roll bearings

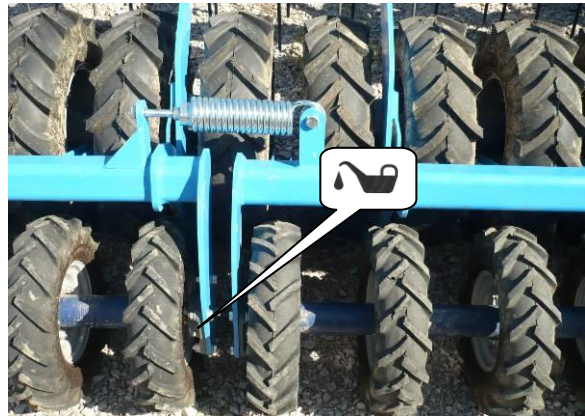

Picture 71 – Bearings of axle



Picture 72 – Handle for setting the harrowing

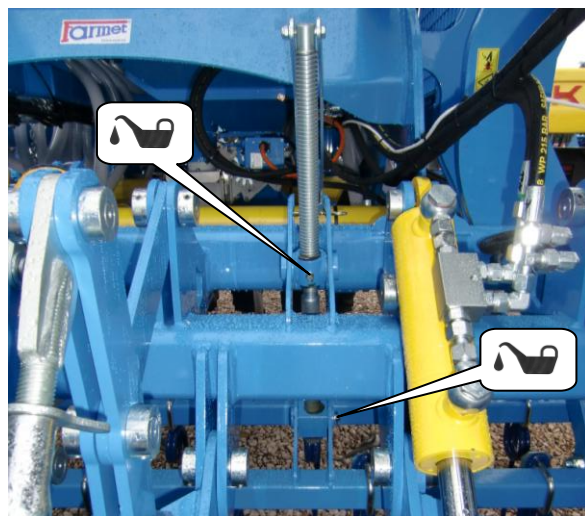

MANIPULATION WITH LUBRICANTS:

- Handle lubricants and oils as hazardous waste according to the valid acts and regulations.
- Protect yourself from direct contact with oils by using gloves or protective lotion.
- Wash oil stains on skin thoroughly with warm water and soap. Do not clean the skin with petrol, diesel oil or other dissolving agents.
- Oil is poisonous. If you swallow any, immediately seek a doctor.
 - Keep lubricants out of reach of children.

RECOMMENDED TIGHTENING MOMENTS OF BOLTING

| BOLTING | TIGHTENING MOMENT | NOTE |
|-------------------------------|-------------------|--|
| M8x1 | 8Nm | Fastening screws of house bearings |
| M8 (8.8) | 25Nm | |
| M10 (12.9) | 85Nm | Share screws |
| M12 (8.8) | 87Nm | House bearings |
| M16 (8.8) | 210Nm | Rubber-tyred roller wheels |
| M 20 (8.8) | 50Nm | Rotary harrowing screws |
| M20 (8.8) | 410Nm | Protection screws, axle rubber-tyred roller wheels |
| M24 (8.8) | 710Nm | Hopper screws |
| HYDRAULIC + AIR JOINTS | | |
| M16x1,5 | 60Nm | Hydraulic screwing, air screwing |
| M22x1,5 | 140Nm | Hydraulic screwing, air screwing |

10. STORING THE MACHINE

When you put the machine out of operation for a longer-period of time:

- Store the machine under a roof, if possible.
- Store the machine on an even and solid ground with sufficient bearing capacity.
- Clean the machine before storing and make sure that the machine is not damaged during the storage. Pay special attention to all labelled lubricating places and lubricate the machine according to the lubrication plan.
- Store the machine with folded frames in the transport position. Leave the machine on the axle and the standing leg; secure the machine against movement with wedges or other suitable instruments.
- The machine must not be leaning on the shares as they may get damaged.
- Prevent access by unauthorized persons to the machine.

11. PROTECTION OF ENVIRONMENT

- Check the tightness of the hydraulic system regularly.
- Replace or repair hydraulic tubes or other parts of the hydraulic system showing signs of damage, before oil starts to leak.
- Check the condition of hydraulic tubes and execute their timely replacement. The usable life of hydraulic tubes also includes the storage time.
- Deal with oils and fats according to valid acts and regulations on wastes.

12. DISPOSAL OF THE MACHINE AFTER THE END OF ITS USABLE LIFE

- The operator must make sure that the steel parts and parts in which the hydraulic oil or lubricant is used are separated for disposal.
- The operator will cut the steel parts according to safety regulations and hand them over to the scrap yard for secondary raw materials. For other parts follow the valid acts on wastes.

13. MAINTENANCE AND TERMS OF GUARANTEE

13.1.MAINTENANCE

Maintenance is provided by a business representative after a consultation with the producer or by the producer. Spare parts are provided through the sales network of individual sellers all over the Czech Republic. Use only spare parts according to the Spare Parts Catalogue officially published by the producer.

13.2.GUARANTEE

- 13.2.1 The producer provides 24-month guarantee for the following parts of the machine: main frame, axle and pole of the machine. The producer provides 12-month guarantee for the remaining parts of the machine. The guarantee starts on the date of the sale of the new machine to the end consumer (user).
- 13.2.2 The guarantee applies to hidden defects that appear during the proper use of the machine during the guarantee period and according to the terms and conditions stated in the instructions for use.
- 13.2.3 The guarantee does not apply to spare parts that can be worn out, i.e. to regular wear and tear of replaceable working parts (shares, blades etc.).
- 13.2.4 The guarantee does not apply to indirect consequences due to potential damage, such as decrease in the usable life etc.
- 13.2.5 The guarantee is related to the machine and does not cease to exist when the owner changes.
- 13.2.6 The guarantee is limited to disassembly and assembly, or replacement or repair of the faulty part. The contractual service of the company Farmet a.s. decides whether the faulty part will be replaced or repaired.
- 13.2.7 Only the authorized service technician of the producer may perform repairs or other interventions in the machine during the guarantee period, otherwise the guarantee will not be accepted. This provision does not apply to the replacement of spare parts that can be worn out (see Item 13.2.3).
- 13.2.8 The guarantee is conditioned by the use of original spare parts of the producer.



Report on the Delivery of the Machine and Putting into Operation

Type of machine:

Serial number of the machine:

Date of delivery and putting into operation:

The following workers were familiarised with the machine, complete instructions for use and maintenance and terms of guarantee:

| Name and surname | Function | Signature |
|------------------|----------|-----------|
| 1. | | |
| 2. | | |
| 3. | | |
| 4. | | |

The following documents were delivered with the machine:

| | | |
|-----------------------|-----|----|
| Log book | YES | NO |
| Instructions for use | YES | NO |
| Spare parts catalogue | YES | NO |

Other documents.....

The guarantee will not be accepted if the machine is operated by other persons than those stated in this report or if there have been any interventions in the machine that are not determined by the instructions for use!!!

The machine was delivered with all parts according to the purchase contract, functional and undamaged.

Delivered by (name and surname, function)

Accepted by (name and surname,

Stamp, date and signature

Stamp, date and signature

Send the completed document together with a copy of the letter of guarantee within 5 days since the machine has been put into operation as a registered letter to the address of the producer. The document is groundwork for accepting guarantee.

Farmet a. s.
Jiřinková 276
ČESKÁ SKALICE 552 03



Tel.: +420 491 450 140
Fax.: +420 491 450 136
GSM.: +420 774 715 738

LETTER OF GUARANTEE

MACHINE MODEL:

YEAR OF PRODUCTION/SERIAL NUMBER: _____

TECHNICAL INSPECTION: _____

BUYER (ADDRESS): _____

SELLER (ADDRESS): _____

GUARANTEE TERMS AND CONDITIONS:

- I. The producer provides 24-month guarantee for the following parts of the machine: main frame, axle and pole of the machine. The producer provides 12-month guarantee for the remaining parts of the machine. The guarantee starts on the date of the sale of the new machine to the end consumer (user).
- II. The guarantee applies to hidden defects that appear during the proper use of the machine during the guarantee period and according to the terms and conditions stated in the instructions for use.
- III. The guarantee does not apply to spare parts that can be worn out, i.e. to regular wear and tear of replaceable working parts (shares, blades etc.).
- IV. The guarantee does not apply to indirect consequences due to potential damage, such as decrease in the usable life etc.
- V. The guarantee is related to the machine and does not cease to exist when the owner changes.
- VI. The guarantee is limited to disassembly and assembly, or replacement or repair of the faulty part. The contractual service of the company Farmet a.s. decides whether the faulty part will be replaced or repaired.
- VII. The guarantee can only be accepted if the machine has been into operation under professional supervision (see the Report on the Delivery of the Machine and Putting into Operation) and if guarantee inspections prescribed by the producer are performed (see Instructions for Use).
- VIII. Only an authorized service technician of the producer may perform repairs or other interventions in the machine during the guarantee period, otherwise the guarantee will not be accepted. This provision does not apply to the replacement of spare parts that can be worn out (see Item III).
- IX. The guarantee is conditioned by the use of original spare parts of the producer.

MANUFACTURER

SELLER

DATE

DATE OF THE FIRST SALE

ⒸES PROHLÁŠENÍ O SHODĚ
ⒸCE CERTIFICATE OF CONFORMITY
ⒸEG-KONFORMITÄTSEKTLÄRUNG
ⒸDÉCLARATION CE DE CONFORMITÉ
ⒸСЕРТИФИКАТ СООТВЕТСТВИЯ ЕС
ⒸDEKLARACJA ZGODNOŚCI WE

1. ⒸMy ⒸWe ⒸWir ⒸNous ⒸМы ⒸMy: **Farmet a.s.**
Jiřinková 276
552 03 Česká Skalice
Czech Republic
DIČ: CZ46504931
Tel/Fax: 00420 491 450136

ⒸVydáváme na vlastní zodpovědnost toto prohlášení. ⒸHereby issue, on our responsibility, this Certificate. ⒸGeben in alleiniger Verantwortung folgende Erklärung ab. ⒸPublions sous notre propre responsabilité la déclaration suivante. ⒸПод свою ответственность выдаем настоящий сертификат. ⒸWydajemy na własną odpowiedzialność niniejszą Deklarację Zgodności.

2. ⒸStrojní zařízení: - název : **Radličkový sečí stroj**
ⒸMachine: - name : **Share sowing machine**
ⒸFabrikat: - Bezeichnung : **Sämaschine**
ⒸMachinerie: - dénomination : **Planteuses à lames**
ⒸСельскохозяйственная машина: - наименование : **Лемешная сеялка**
ⒸUrządzenie maszynowe: - nazwa : **Siewnik radelkowy**
- typ, type : **EXCELENT Premium**
- model, modèle : **EXCELENT Premium 6**
- Ⓒvýrobní číslo :
- Ⓒserial number
- ⒸFabriknummer
- Ⓒn° de production
- Ⓒзаводской номер
- Ⓒnumer produkcyjny:

3. ⒸPříslušná nařízení vlády: č.176/2008 Sb. (směrnice 2006/42/ES). ⒸApplicable Governmental Decrees and Orders: No.176/2008 Sb. (Directive 2006/42/ES). ⒸEinschlägige Regierungsverordnungen (NV): Nr.176/2008 Slg. (Richtlinie 2006/42/ES). ⒸDécrets respectifs du gouvernement: n°.176/2008 du Code (directive 2006/42/CE). ⒸСоответствующие постановления правительства: № 176/2008 Сб. (инструкция 2006/42/ES). ⒸOdpowiednie rozporządzenia rządowe: nr 176/2008 Dz.U. (Dyrektywa 2006/42/WE).

4. ⒸNormy s nimiž byla posouzena shoda: ⒸStandards used for consideration of conformity: ⒸDas Produkt wurde gefertigt in Übereinstimmung mit folgenden Normen: ⒸNormes avec lesquelles la conformité a été évaluée: ⒸНормы, на основании которых производилась сертификация: ⒸNormy, według których została przeprowadzona ocena: ČSN EN ISO 12100, ČSN EN ISO 4254-1.

ⒸSchválil ⒸApprove by dne: 01.06.2012
ⒸBewilligen ⒸApprouvé
ⒸУтвердил ⒸUchwalif

V České Skalici dne: 01.06.2012

p. Gavlas Dušan
technický ředitel
Technical director

Farmet a.s.
Jiřinková 276
552 03 Česká Skalice
DIČ CZ46504931
38

Ing. Karel Žďárský
generální ředitel společnosti
General Manager



ⒸES PROHLÁŠENÍ O SHODĚ
ⒸCE CERTIFICATE OF CONFORMITY
ⒸEG-KONFORMITÄTSEKTLÄRUNG
ⒸDÉCLARATION CE DE CONFORMITÉ
ⒸСЕРТИФИКАТ СООТВЕТСТВИЯ ЕС
ⒸDEKLARACJA ZGODNOŚCI WE

1. ⒸMy ⒸWe ⒸWir ⒸNous ⒸМы ⒸМы: **Farmet a.s.**
Jiřinková 276
552 03 Česká Skalice
Czech Republic
DIČ: CZ46504931
Tel/Fax: 00420 491 450136

ⒸVydáváme na vlastní zodpovědnost toto prohlášení. ⒸHereby issue, on our responsibility, this Certificate. ⒸGeben in alleiniger Verantwortung folgende Erklärung ab. ⒸPublions sous notre propre responsabilité la déclaration suivante. ⒸПод свою ответственность выдаем настоящий сертификат. ⒸWydajemy na własną odpowiedzialność niniejszą Deklarację Zgodności.

2. ⒸStrojní zařízení: - název : **Radličkový sečí stroj**
ⒸMachine: - name : **Share sowing machine**
ⒸFabrikat: - Bezeichnung : **Sämaschine**
ⒸMachinerie: - dénomination : **Planteuses à lames**
ⒸСельскохозяйственная машина: - наименование : **Лемешная сеялка**
ⒸUrządzenie maszynowe: - nazwa : **Siewnik radelkowy**
- typ, type : **EXCELENT Premium**
- model, modèle : **EXCELENT Premium 8**
- Ⓒvýrobní číslo :
- Ⓒserial number
- ⒸFabriknummer
- Ⓒn° de production
- Ⓒзаводской номер
- Ⓒnumer produkcyjny:

3. ⒸPříslušná nařízení vlády: č.176/2008 Sb. (směrnice 2006/42/ES). ⒸApplicable Governmental Decrees and Orders: No.176/2008 Sb. (Directive 2006/42/ES). ⒸEinschlägige Regierungsverordnungen (NV): Nr.176/2008 Slg. (Richtlinie 2006/42/ES). ⒸDécrets respectifs du gouvernement: n°.176/2008 du Code (directive 2006/42/CE). ⒸСоответствующие постановления правительства: № 176/2008 Сб. (инструкция 2006/42/ES). ⒸOdpowiednie rozporządzenia rządowe: nr 176/2008 Dz.U. (Dyrektywa 2006/42/WE).

4. ⒸNormy s nimiž byla posouzena shoda: ⒸStandards used for consideration of conformity: ⒸDas Produkt wurde gefertigt in Übereinstimmung mit folgenden Normen: ⒸNormes avec lesquelles la conformité a été évaluée: ⒸНормы, на основании которых производилась сертификация: ⒸNormy, według których została przeprowadzona ocena: ČSN EN ISO 12100, ČSN EN ISO 4254-1.

ⒸSchválil ⒸApprove by dne: 01.06.2012
ⒸBewilligen ⒸApprouvé
ⒸУтвердил ⒸUchwalif

V České Skalici dne: 01.06.2012

p. Gavlas Dušan
technický ředitel
Technical director

Farmet a.s.
Jiřinková 276
552 03 Česká Skalice
DIČ CZ46504931
38

Ing. Karel Žďárský
generální ředitel společnosti
General Manager

