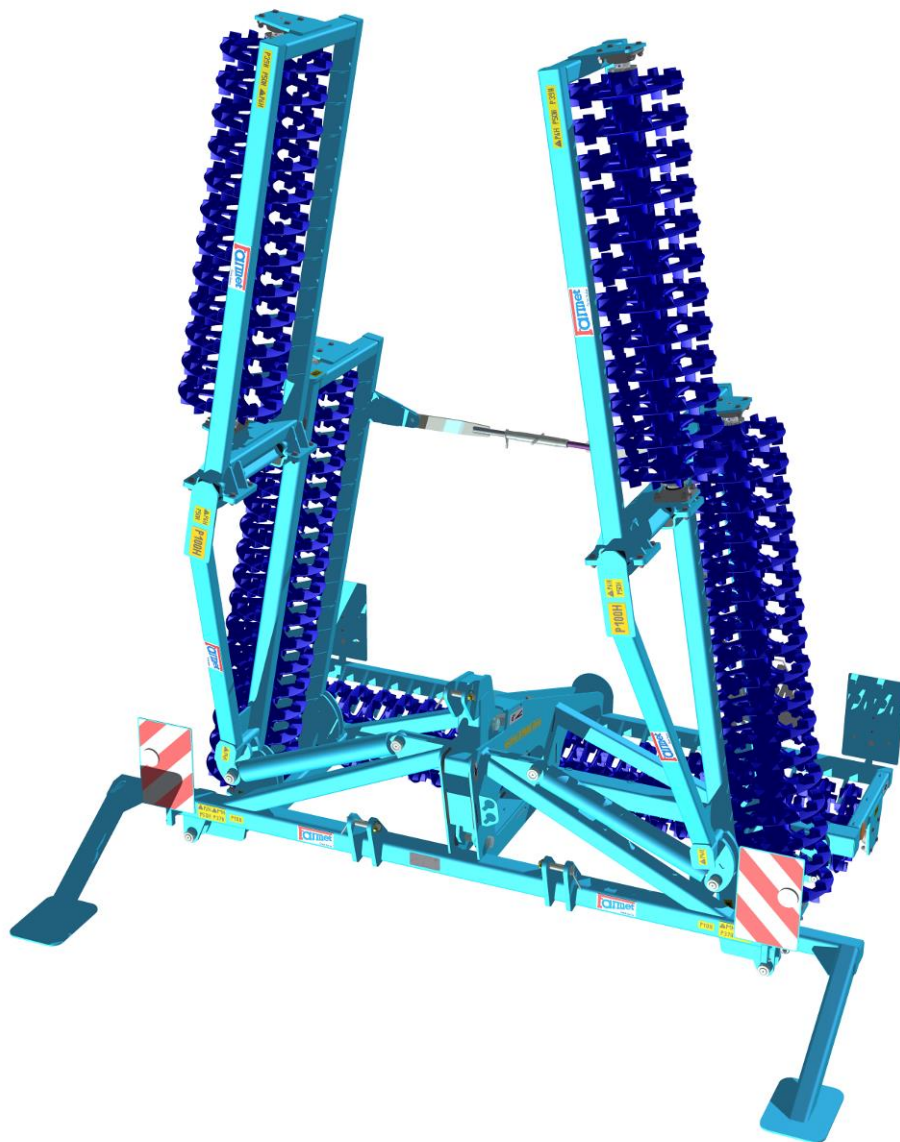


OPERATING MANUAL

CRUMBLING ROLLER

DV – 400C / 10000NS



Edition : 2 | Effective from : 1. 8. 2023

Dear Customer,

The mounted folding Crumbling Rollers of the DV 400 Series are quality products by Farmet a.s., Česká Skalice, Czech Republic.

Advantages and assets of your machine can only be fully utilized after studying these Operating manual thoroughly.

The serial number of the machine is stamped on the index plate and mentioned in the Operating manual (see Tab. 1). This serial number should be mentioned for reference when ordering spare parts or a possible repair. The index plate is located on the front part of the frame, next to the lower suspension.

All spare parts should be ordered according to the official **Spare Part Catalogue** issued by Farmet a.s., Česká Skalice, Czech Republic.

The Use of Your Machine

The DV Crumbling Roller is intended for compacting and levelling the surface of the field and, possibly, for crumbling bigger lumps in the field. It can be used either individually or in combination with a model of "Kompaktomat". The machine has been designed for tractors with the output of 60 kW. The optimal performance of the Crumbling Roller is at 12 to 14 km p. h.

Index plate of the machine:



Table 1 - Your Machine Characteristics

MACHINE TYPE	
MACHINE SERIAL NUMBER	
SPECIAL DESIGN OR ACCESSORIES	
.....	
.....	
.....	
.....	

- TABLE OF CONTENTS	Page 3
- LIMIT PARAMETERS	Page 4
TECHNICAL PARAMETERS	Page 4
SAFETY STATEMENT	Page 4
- A. GENERAL INSTRUCTIONS FOR USE	Page 5
PROTECTIVE TOOLS	Page 5
- B. MACHINE TRANSPORT USING TRANSPORT MEANS	Page 6
- C. MACHINE HANDLING USING LIFTING EQUIPMENT	Page 6
- D. WORK SAFETY LABELS	Page 6
- 1. MACHINE DESCRIPTION	Page 10
- 2. MACHINE ASSEMBLY AT THE CUSTOMER	Page 12
- 3. COMMISSIONING	Page 12
3.1. AGGREGATION TO A TRACTOR	Page 13
3.2. AGGREGATION OF THE MACHINE WITH FARMET KOMPAKTOMAT	Page 13
3.3. HYDRAULICS CONNECTION	Page 14
3.4. FOLDING AND UNFOLDING OF THE MACHINE	Page 15
- 4. MACHINE TRANSPORT ON ROADS	Page 17
- 5. ADJUSTING THE LENGTH OF THE TOP THREE-POINT HITCH DRAWBAR	Page 17
- 6. MACHINE MAINTENANCE AND REPAIRS	Page 19
6.1 REPLACING THE WORKING TOOLS	Page 20
6.2 REPLACEMENT OF THE WORKING ROLLER BEARINGS	Page 20
6.2.1 USING THE TOOL FOR BEARING DISASSEMBLY AND ASSEMBLY	Page 21
6.2.2 USING SPACER	Page 25
- 7. MACHINE STORAGE	Page 26
- 8. MACHINE LUBRICATION SCHEDULE	Page 26
- 9. ENVIRONMENTAL PROTECTION	Page 27
- 10. MACHINE DISPOSAL AFTER SERVICE LIFE EXPIRY	Page 27
- 11. SERVICING AND WARRANTY CONDITION	Page 27
11.1. SERVICING	Page 27
11.2. WARRANTY	Page 27
- CE CERTIFICATE OF CONFORMITY	Page 28

LIMIT PARAMETERS

- ^(x) The machine is intended for compacting and levelling the surface of the field and, possibly, for crumbling bigger lumps in the field. Another type of use exceeding the determined purpose is forbidden.
- ^(x) The machine is only operated by one person – the tractor driver.
- ^(x) Machine operator must not use the machine in a different way, especially:
 - ^(x) Transport of persons and animals on the machine structure
 - ^(x) Transport of burdens on the machine structure
 - ^(x) Aggregation of the machine with another towing equipment than stated in Chapter "3.1, 3.2".

TECHNICAL PARAMETERS

Tab. 2 – Technical parameters

PARAMETERS	DV 400C/10000
Operating Width (mm)	9850
Transport Width (mm)	2912
Transport Height (mm)	3755
Transport Length (mm)	2180
Number of the Crosskill Wheels	81
Operating Performance (Hectares per Hour)	7 - 10
Towing Vehicle (kW)	50
Operating Speed (km per hour)	12 – 14
Max. Transport Speed (km.p.h.)	20
Maximum Slope Accessibility	6°
Weight (kg)	2550

SAFETY STATEMENT



This warning sign warns about an immediate dangerous situation ending with death or severe injury.



This warning sign warns about a dangerous situation ending with death or severe injury.



This warning sign warns about a situation that may end with a smaller or slight injury. It also warns about dangerous actions related to the activity that could lead to an injury.

A. GENERAL INSTRUCTIONS FOR USE

A.1 ^(x) The machine is made in accordance with the latest equipment state and approved safety regulations. However, dangers of user or third person injury or machine damage or creation of other material damage may arise during use.

A.2 ^(xx) Use the machine only in a technically sound condition, in accordance with its purpose, aware of possible dangers, and while adhering to the safety instructions of this operating manual! Immediately remove especially the failures that may negatively affect safety!

A.3 ⁽⁷⁾ Machine operation may be performed by a person authorised by the operator under these conditions:


- ⁽⁸⁾ It must own a valid driver's licence of the corresponding category,
- ⁽⁹⁾ It must be demonstrably familiarised with the safety regulations for work with the machine and must practically master the machine operation,
- ⁽¹⁰⁾ The machine may not be operated by juveniles.
- ⁽¹¹⁾ It must know the meaning of the safety signs located on the machine. Their respecting is important for safe and reliable machine operation.

A.4 ⁽¹²⁾ Maintenance and servicing repairs on the machine may only be performed by a person:


- ⁽¹³⁾ Authorised by the operator,
- ⁽¹⁴⁾ Educated in the machinery field with knowledge of repairs of similar machines,
- ⁽¹⁵⁾ Demonstrably familiarised with safety regulations for work with the machine,
- ⁽¹⁶⁾ During a repair of a machine connected to a tractor, it must own a driver's licence of the corresponding category.


A.5 ⁽¹⁷⁾ Machine operator must secure the safety of other persons when working with the machine or transporting the machine.

A.6 ⁽¹⁸⁾ During machine work in the field or during transport, the operator must control the machine from the tractor's cabin.


 **A.7** ⁽¹⁹⁾ The operator may enter the machine structure only with the machine at rest and blocked against movement, namely only for these reasons:

- ⁽²⁰⁾ Adjustment of the machine working parts,
- ⁽²⁵⁾ Unlocking the connecting rod before unfolding the lateral frames.

 **A.8** ^(xxx) When stepping on the machine, do not step on roller tyres or other rotary parts. Those may turn and you can cause very serious injuries by the subsequent fall.

 **A.9** ⁽²²⁾ Any changes or modifications of machine may be performed only with written consent of the manufacturer. For possible damage arisen due to ignoring this instruction, the producer bears no responsibility. The machine must be maintained equipped with prescribed accessories and equipment including safety marking. All warning and safety signs must be legible and in their places. In case of damage or loss, these signs must be immediately renewed.

A.10 ⁽²³⁾ The operator must have the Operating Manual with the work safety requirements available at any time when working with the machine.

 **A.11** ⁽²⁴⁾ The operator must not consume alcohol, medicines, narcotic and hallucinogenic substances that decrease his attention and coordination capabilities while using the machine. If the operator must use medicines prescribed by a physician or uses freely sold medicines, he must be informed by a physician, whether he is capable of responsible and safe operation of the machine under these circumstances.


Protective Tools

For the operation and maintenance use:



- Tight clothes
- Protective gloves and goggles for protection against dust and sharp parts of the machine



B. MACHINE TRANSPORT USING TRANSPORT MEANS

- B.1 ⁽¹⁾ The transport means designed for machine transport must have the load capacity minimally identical with the weight of the transported machine. The total weight of the machine is stated on the production label.
- B.2 ⁽²⁾ The dimensions of the transported machine including the transport means must comply with the valid regulations for road traffic (decrees, laws).
-  B.3 ⁽³⁾ The transported machine must be always fastened to the transport means so that its spontaneous loosening could not happen.
- B.4 ⁽⁴⁾ The carrier is responsible for damage caused by the loosening of incorrectly or insufficiently fastened machine to the transport means.

C. MACHINE HANDLING USING LIFTING EQUIPMENT

- C.1 ⁽¹⁾ The lifting equipment and tying means designed for handling of the machine must have their load capacity at least identical with the weight of the handled machine.
-  C.2 ⁽²⁾ Machine fastening for handling may only be performed in places designed for that and marked with self-adhesive labels showing the "chain" symbol. 
- C.3 ⁽³⁾ After fastening (suspending) at designated points, it is forbidden to move in the space of possible reach of the handled machine.

D. WORK SAFETY LABELS

Warning safety labels serve for operator protection.

General:


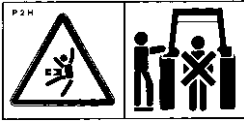
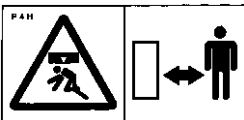
D.1 Strictly observe the warning safety labels.

D.2 All safety instructions also apply to other users.

D.3 Upon damage or destruction of the aforementioned "SAFETY LABEL" located on the machine, THE OPERATOR IS OBLIGED TO REPLACE IT WITH A NEW ONE!!!

The position, appearance, and precise meaning of work safety labels on the machine is determined in the following table (Tab. 3) and in the figure (Fig. 1, 2).

Table 3 – Self-adhesive warning safety labels located on the machine

WARNING SAFETY LABEL	LABEL TEXT	MACHINE POSITION
	Read the Operating manual carefully before operation. When operating the machine, observe all the related safety instructions and regulations.	P 1 H
	Do not step between the tractor and the machine when coupling or uncoupling. Do not step between the tractor and the machine until they are at rest and the engine turned off.	P 2 H
	Keep away of the reach of the lifted machine.	P 4 H

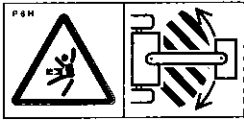

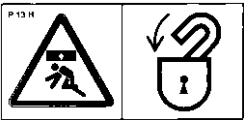


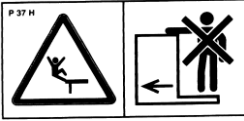

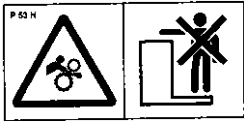
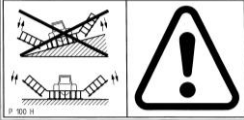
	<p>Keep away from the reach of the tractor + machine if the tractor engine is running or the set moving.</p>	<p>P 6 H</p>
	<p>Before uncoupling the machine from the tractor, it should be supported with the telescopic foot so that it cannot fall down.</p>	<p>P 10 H</p>
	<p>Secure the lateral frames with the connecting rod against undesirable unfolding before transporting the machine.</p>	<p>P 13 H</p>
	<p>Do not insert your hands in the lateral and central frames contact space when unfolding the lateral frames into the working position.</p>	<p>P 20 H</p>
	<p>Keep a safe distance from electric devices when working with the machine or transporting it.</p>	<p>P 39 H</p>
	<p>Transportation on the machine is strictly forbidden.</p>	<p>P 37 H</p>
	<p>Keep away of the reach of the lateral frames when folding or unfolding them</p>	<p>P 50 H</p>
	<p>Keep away from rotating parts of the machine unless they are at rest</p>	<p>P 53 H</p>
	<p>It is not allowed to fold and unfold the side frames of the machine while standing on a slope or inclined surface.</p>	<p>P 100 H</p>

Fig. 1 - Location of safety labels on the machine

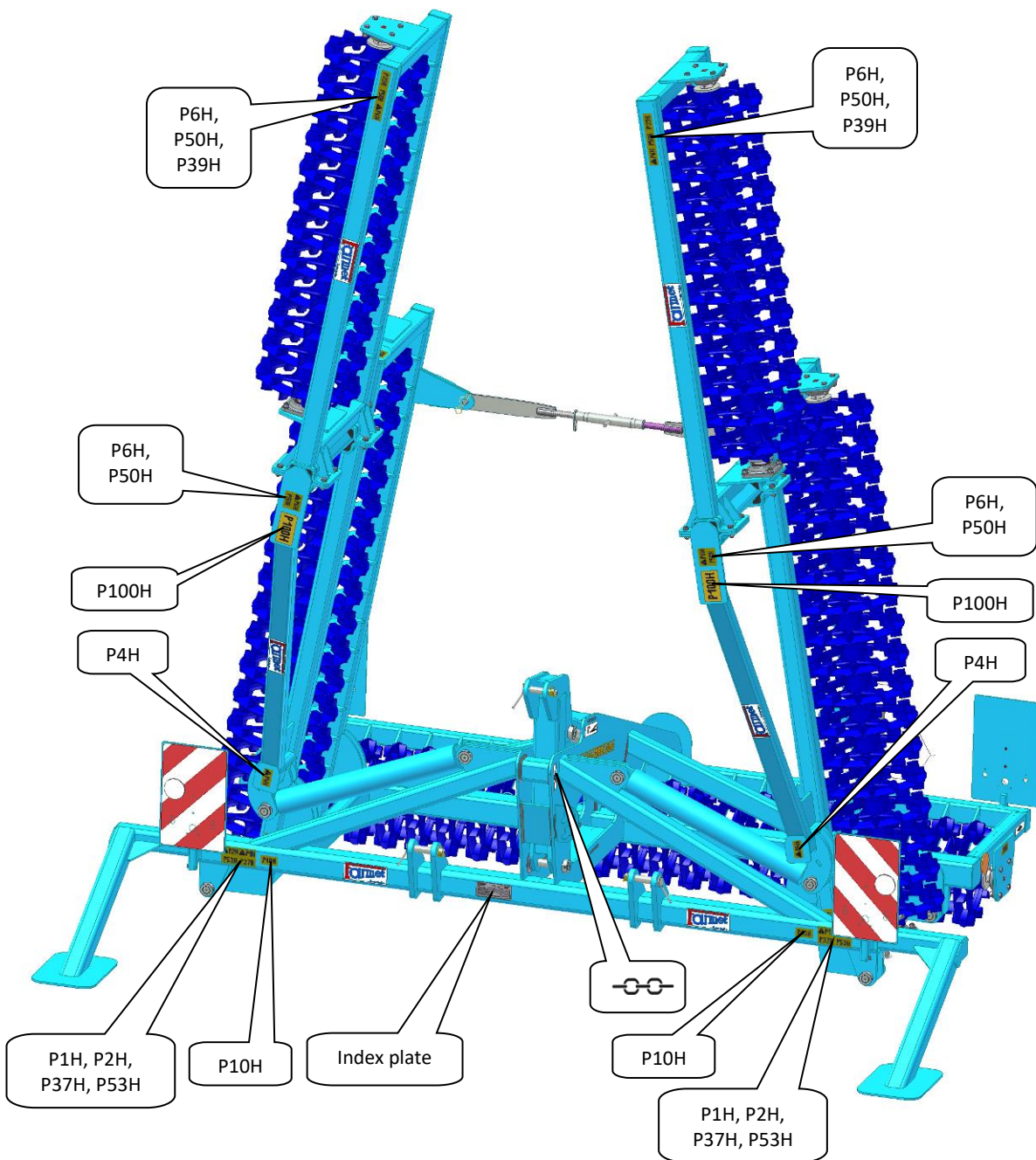
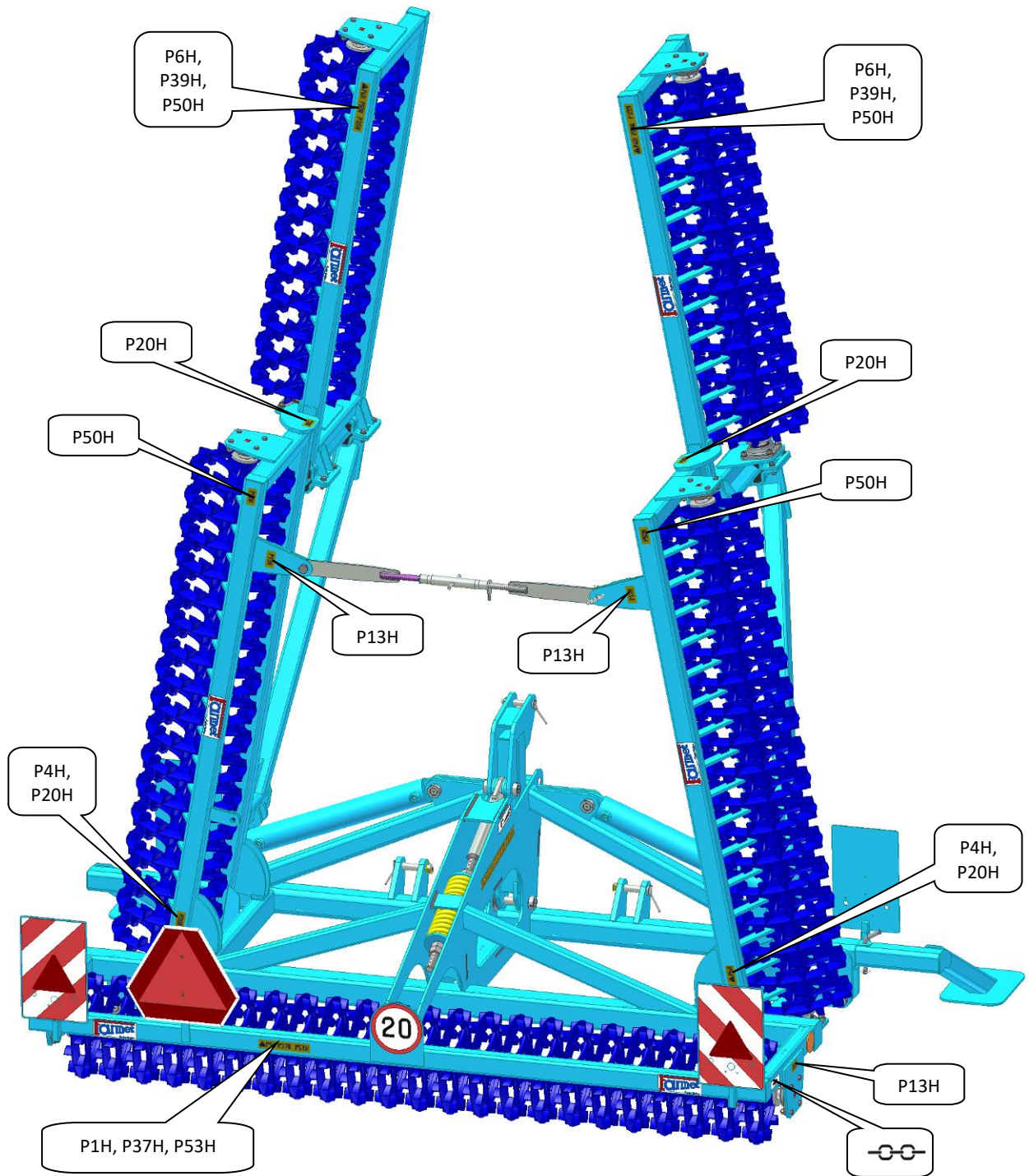


Fig. 2 - Location of safety labels on the machine



1. MACHINE DESCRIPTION

The DV 400C Crumbling Rollers are designed as mounted and folding machines. It consists of five supporting frames (Fig. 3, Fig. 4), where the central frame is equipped with a three-point hitch, type TBZ 2, with the third point being spring-loaded. The side frames are also spring-loaded with rubber segments. Each frame is equipped with a section of working crosskill wheels, with a diameter of 400 mm. The folding and unfolding of lateral frames are carried out by means of linear hydraulic motors connected to the outer circuit of the tractor hydraulic system.

Fig. 3 - Machine Description - unfolded

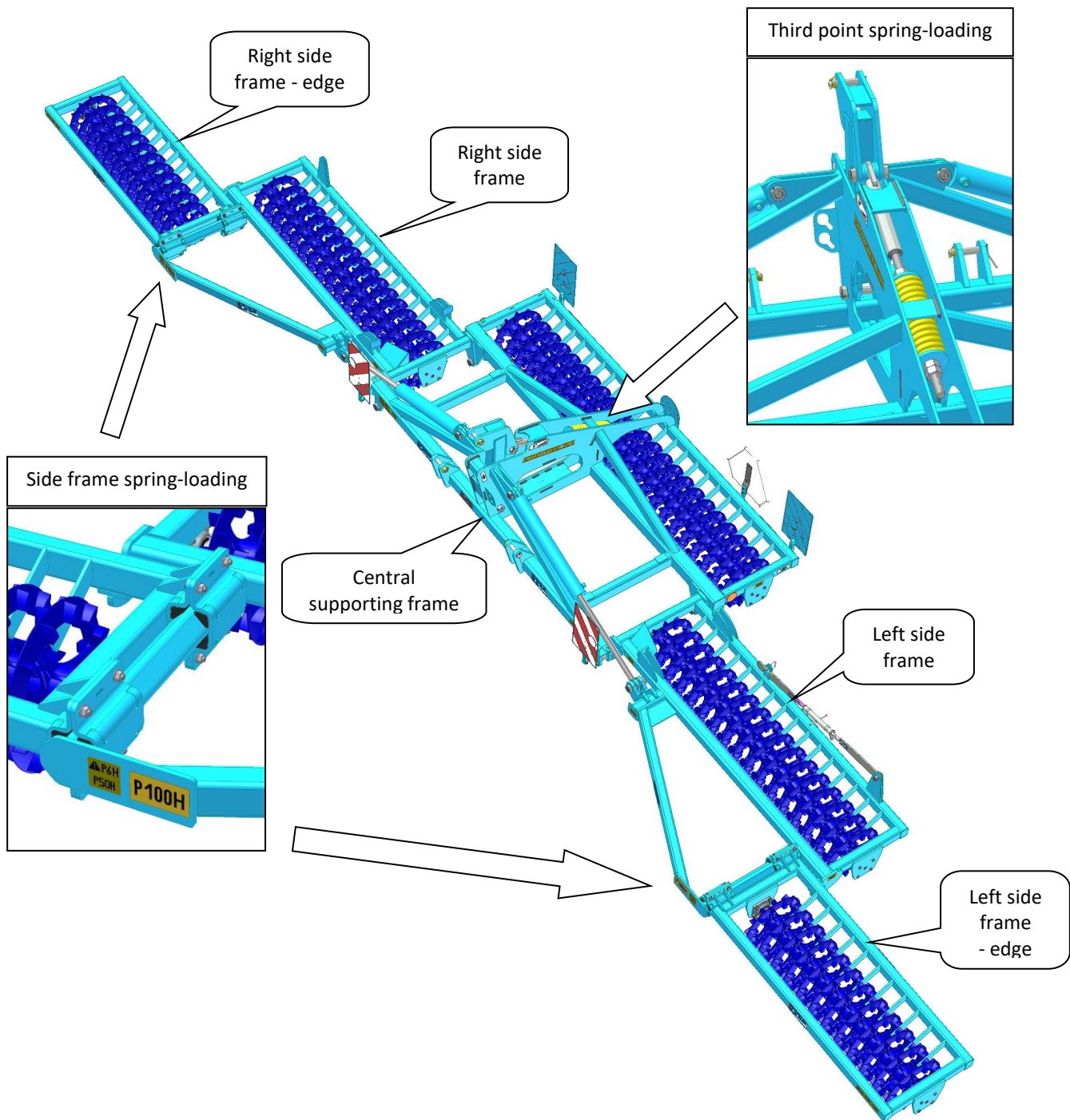
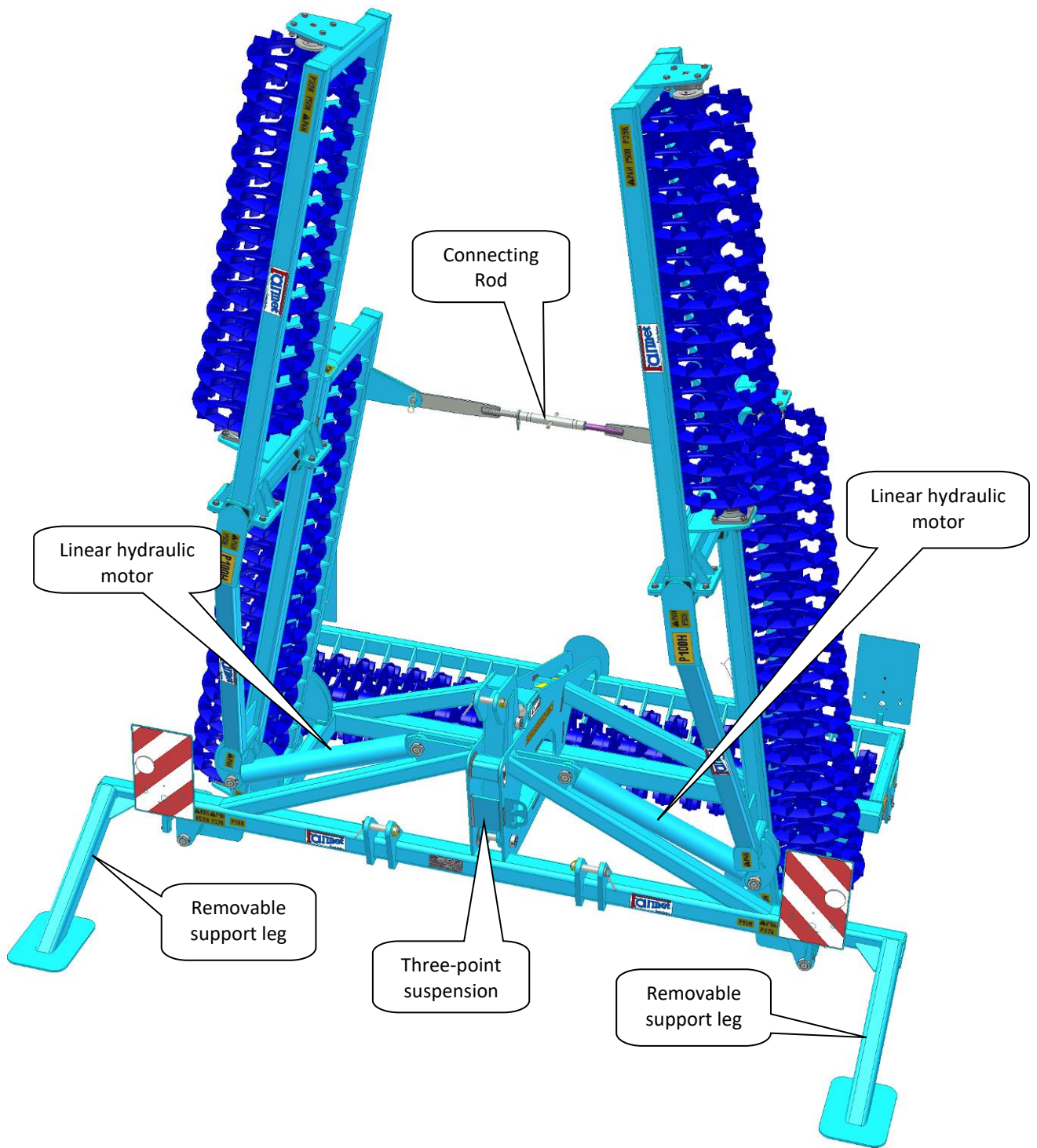


Fig. 4 - Machine Description – folded



THE SUPPORT LEGS CAN ONLY BE USED WHEN THE MACHINE IS FOLDED.
THE LEGS HAVE TO BE DISASSEMBLED PRIOR TO UNFOLDING THE MACHINE.

2. MACHINE ASSEMBLY AT THE CUSTOMER



- The operator must perform the assembly according to the instructions of the producer, best in cooperation with the expert servicing technician determined by the producer.
- The operator must secure a functional test of all assembled parts after the completion of the machine assembly.
- The operator must secure that the handling of the machine using lifting equipment during its assembly is in accordance with chapter "C".

3. COMMISSIONING



- Before taking over the machine, test and check, whether damage occurred during transport and whether all parts contained in the bill of delivery were supplied.
- Before commissioning the machine, carefully read this operating manual, especially Chapters **A-D**. Before the first use of the machine, familiarise yourselves with its controls and overall function.
- During work with the machine, observe not only the instructions of this operating manual, but also generally valid regulations of work safety, health protection, fire and transport safety, and environmental protection.
- The operator must check the machine before every use (commissioning) from the standpoint of completeness, work safety, work hygiene, fire safety, transport safety, and environmental protection. A machine showing signs of damage must not be commissioned.
- Aggregation of the machine with the tractor is to be performed on a flat and hardened surface.
- When working on slopes, observe the lowest allowable slope grade of the set **TRACTOR - MACHINE**.
- Before starting the tractor motor, check whether no person or animal is in the working space of the set and push the warning sound signal.
- The operator is responsible for the safety and all damage caused by the operation of the tractor and the connected machine.
- The operator is obliged to adhere to the technical and safety regulations of the machine determined by the producer when working.
- When working with the machine, the operator(s) must observe the prescribed speed according to the Manual, Table 2.
- The operator is obliged to lower the machine to the ground and secure the set against movement before leaving the tractor cabin.

3.1. AGGREGATION TO A TRACTOR

- The machine can be connected only to a tractor, whose curb weight is identical or higher than the overall weight of the connected machine.
- The machine operator must observe all generally valid regulations of work safety, health protection, fire safety, and environmental protection.
- The operator may connect the machine exclusively to a tractor that is equipped with a rear three-point suspension and a functional undamaged hydraulic system.
- **When the machine has been aggregated to a tractor, remove the support legs prior to unfolding the machine (Fig. 7)**
- The table of requirements for the towing means for work with the machine:

Requirement for the tractor engine power for machine	DV 400C / 10000	60 kW
Requirement for the tractor's TPS	Lower suspension joints spacing (measured on the joint axes)	870+/- 1,5 mm
	Diameter of the hole in the lower suspension joints for the machine suspension hinged pins	28,7 – 29,03 mm
	Diameter of the hole in the upper suspension joint for the machine suspension hinged pin	25,7 – 25,91 mm
Tractor hydraulic system requirements	Side frame folding circuit	The pressure in the circuit min. 125 bar – max. 160 bar, one ISO 12,5 quick-coupler socket



When connecting, no persons may stay in the space between the tractor and the machine.

- The machine aggregated with the tractor changes the distribution of the weight to the individual axles of the tractor. The weight of the front axle is reduced and therefore the controllability gets worse. It also affects braking properties.
- For safety reasons, the loading capacity of the axles, the tires and the tractor suspension must be kept. The category of the tool suspension and three-point suspension of the tractor must be the same. Use only the weights prescribed by the tractor manufacturer for balancing.

3.2. AGGREGATION OF THE MACHINE WITH FARMET KOMPAKTOMAT

- The machine can be aggregated with Farmet K1000NS equipped with a rear TBZ 2.
- Prior to aggregation with Farmet Kompaktomat, study the operating instructions for semi-mounted cultivators and proceed according to Chapter 8. AGGREGATION OF KOMPAKTOMAT WITH OTHER EQUIPMENT.
- **When the machine has been aggregated with Farmet Kompaktomat, remove the support legs (Fig. 7)**

3.3. HYDRAULICS CONNECTION

- Connect the hydraulics only when the hydraulic circuits of the machine and the tractor (aggregate) are in a pressure-less condition.
- The hydraulic system is under high pressure. Regularly check for leaks and immediately remove obvious damage of all lines, hoses, and pipe unions.
- When seeking and removing leaks, use only the suitable tools.
- For connecting the hydraulic system of the machine to the tractor, use the plug (on the machine) and the socket (on the tractor) of the quick-couplers of the same type. Perform the connection of the quick-couplers of the machine to the hydraulic circuits of the tractor so that the folding of the side frames (**BLUE DUST CAP** - the slide-out function of the linear hydraulic motor **and WHITE DUST CAP** - the slide-in function of the linear hydraulic motor) is on one control circuit.



In order to prevent accidental or foreign person (children, passengers) caused movement of the hydraulics, the control switchboards on the tractor must be secured or blocked in the transport position.



It is forbidden to disassemble the parts of the hydraulic system that are under pressure. Hydraulic oil that penetrates skin under high pressure causes serious injuries. In case of an injury immediately seek medical help.

HYDRAULIC OIL SPECIFICATIONS

The hydraulic circuit of the machine is filled with oil at the factory:

Performance level: API GL 5; SAE 10W-30; SAE 80




Manufacturer's specification: ALLISON C4; CATERPILLAR TO-4; VOLVO VCE WB 101; 97303 JONH DEERE 20C/20D ZF TE-ML 03E/05F/06E/06F/06K/17E/21F; PARKER

DENISON HF-0/HF-1/HF-2 New HOLLAND NH 420A/410B MASSEY FERGUSON M1135/M1141/M1143/ M1145 KUBOTA UDT Fluid CASE IH MS-1204/MS-

1206/ MS-1207/MS-1209 FORD M2C134D M2C86B/C CNH MAT 3525/ MAT3526 SPERRY VICKERS/EATON M2950S, I-280-S SAUER

SUNDSTRAND(DANFOSS) Hydro Static Trans fluid; CASE CNH MAT 3540(CVT), Claas(CVT), AGCO CVT; ML200, Valtra G2-10(XT-60+)

3.4. FOLDING AND UNFOLDING OF THE MACHINE

-  ▪ With all hydraulic movements, lower the speed of the moving parts of the machine before stopping by throttling the corresponding valve at the control unit!
-  ▪ The hydraulics for the folding and unfolding must be connected to the double-action control unit.
-  ▪ The operator must ensure that during folding and unfolding of the side frames, no person or animal is within their reach (i.e. at the place of their impact, fig.6) or vicinity and that no one puts his fingers into the joint space.
- Perform folding and unfolding on flat and solid surfaces or laterally to the slope with the fully open control unit.
- Remove stuck soil from folding points, soil may impair function and cause damage to the mechanics.
- During folding or unfolding, check the side frames and have them continuously fold into the end position.
- The support legs must be removed prior to unfolding the aggregated machine (Fig. 7).



Before unlocking the connection rod, the operator(s) must secure the set against undesirable motion and check (from the tractor cab) by using the hydraulic system control levers whether or not there is oil in the piston rods. Only after the operator is sure that there is oil in the piston rod, may he proceed to unlocking the connection rod.

Procedure for lowering the machine:

- Lift the machine in the arms of the three-point hitch.
- Lower the side frameworks smoothly.
- Lower the machine to the ground using the arms of the three-point hitch.
- Block or close the controlling unit.
- Fix the connecting rod (Fig. 5a) securing the side frames, be careful and do not enter the space within the reach of the machine (Fig. 6).

Procedure for unfolding the machine:

- Check that the support legs have been removed, if they have not, remove them (Fig. 7).
- If the machine is not resting on the ground, lower the machine in the arms of the three-point hitch to the ground.
- Remove the connecting rod (Fig. 5b), be careful and do not enter the space within the reach of the machine (Fig. 6).
- Lift the machine in the arms of the three-point hitch.
- Unfold the side frameworks smoothly.
- Block or close the controlling unit.

Fig. 5 – connecting rod:

a) position of the connecting rod during transport
- securing side frames

b) position of the connecting rod at work prior to unfolding
- releasing side frames

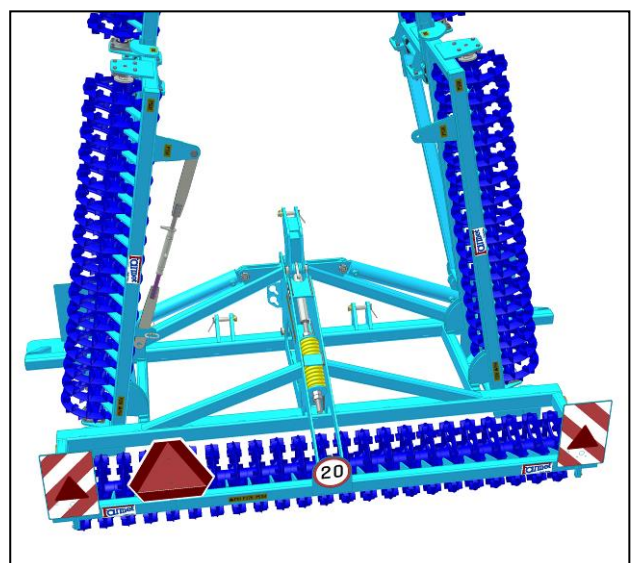
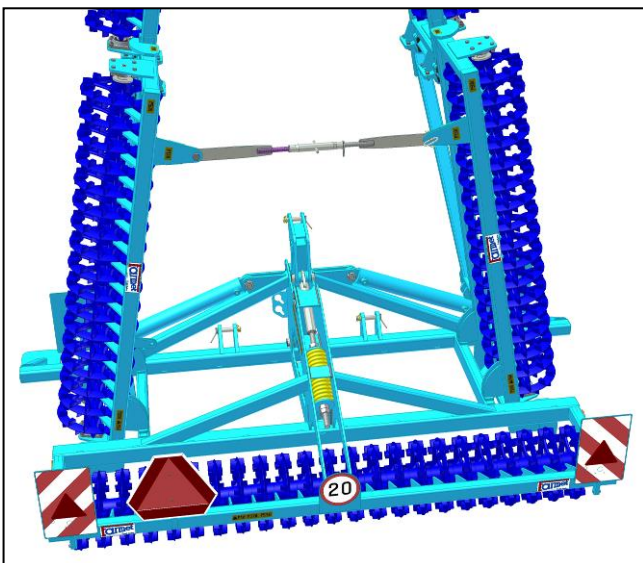


Fig. 6: reach of the machine – do not enter the shaded zone

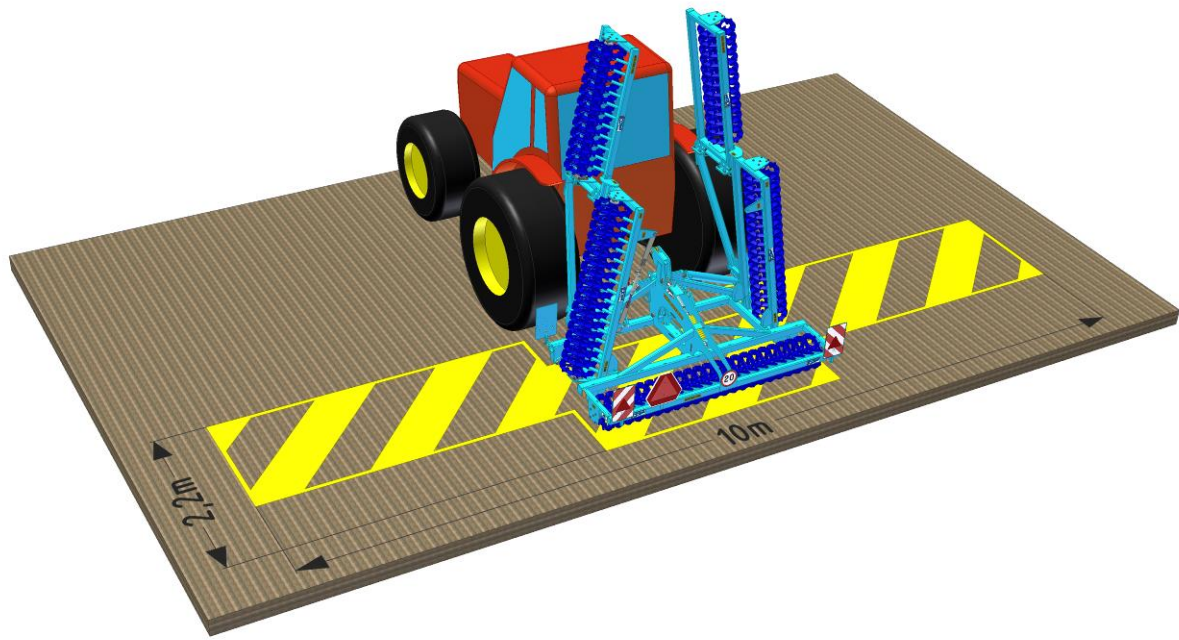
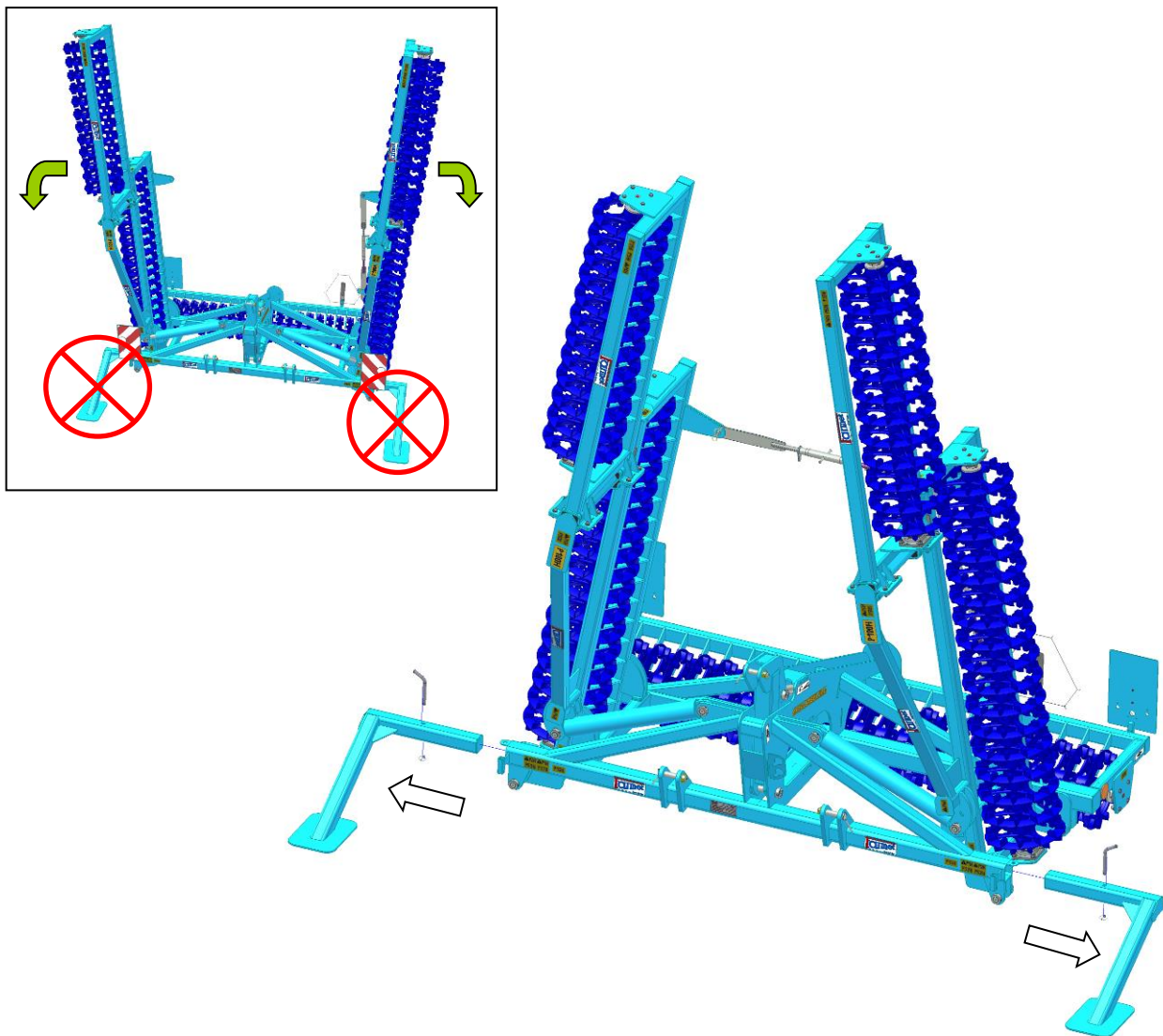


Fig. 7: support legs of the machine – removal (necessary prior to unfolding the machine)



4. MACHINE TRANSPORT ON ROADS

Transport Position of the machine:

- The machine side frames must be tilted down to transport position.
- The machine side frames must be secured by means of the connecting rod (Fig. 5a).
- Connect the machine by linking to the tractor by means of three-point suspension.
- The removable support legs must be removed prior to transportation of the machine (Fig. 7).
- The machine must be equipped with shields with marking of contours, functional lighting, and the triangle of the rear marking for slow vehicles (according to ECE No. 69).
- The lighting must be activated during travelling on roads.
- The tractor must be equipped with a special light device of an orange colour, which must be activated during travelling on roads.
- The maximum transport speed during travelling on roads is **20 kph**.
- Secure the lower shoulders of the tractor TPS from side swing.



Ban of transport with decreased visibility!

- The operator is obliged to pay increased attention during transport on roads, due to the transport dimensions of the machine.
- The operator must observe the valid regulations for transport on roads (laws, decrees) after connecting the machine to the tractor, for reason of a change of the axle load. The driving properties of the set also change depending on the terrain nature, adapt the manner of driving to these conditions.
- The operator is obliged to present the machine certificate of roadworthiness as needed, according to the valid regulations for road traffic (decree, law) (only in the Czech Republic).
- The operator is obliged to secure sufficient outlook during reversing from his position of the tractor driver. In case of insufficient outlook, the operator is obliged to call a competent and informed person.
- For the transport purpose, the operator should tilt the side frames down and secure them against non-required swinging by disconnection of the hydraulic circuit of the machine and tractor.
- The operator must secure the arms of the rear TPS of the tractor in the transport position during road transport, i.e. prevent unexpected arm drop using the hydraulic arm control lever. At the same time, the arms of the rear TPS of the tractor must be secured against side swinging.
- During machine transport on roads, the operator must observe the valid laws and decrees that deal with this topic and which specify the relationships of the tractor axle load depending on transport speed.

5. ADJUSTING THE LENGTH OF THE TOP THREE-POINT HITCH DRAWBAR



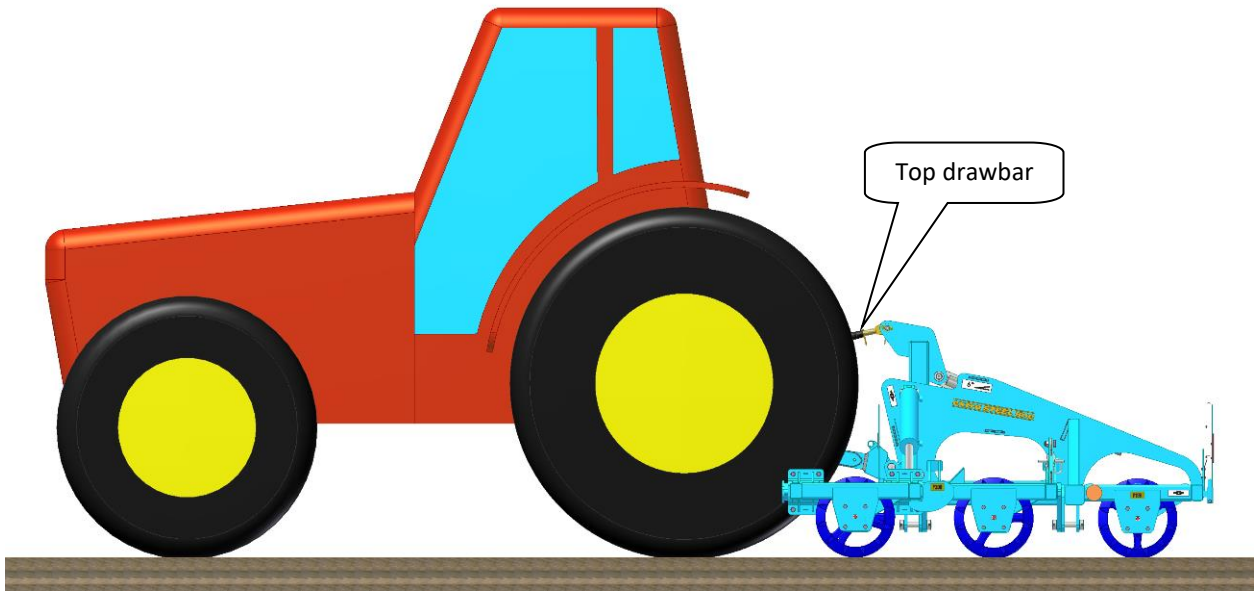
Adjustment should be carried out only on machine positioned on the rollers.

- The length of the top drawbar of the tractor three-point hitch has to be adjusted after the machine is connected to the tractor.

CORRECT ADJUSTMENT OF THE LENGTH OF THE TOP THREE-POINT HITCH DRAWBAR (Fig. 8)

When the length of the drawbar is adjusted correctly, the machine stands on the ground in parallel with the ground when lowered down, i.e., all three rows of rollers are in plane with the ground. This ensures an even distribution of force on the entire machine.

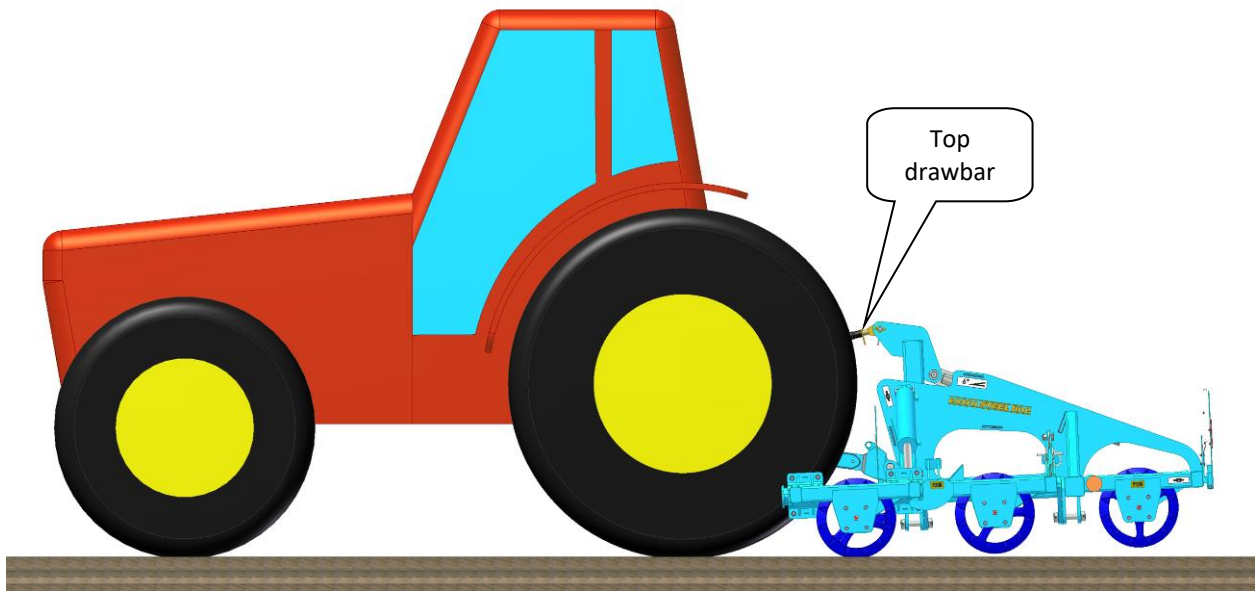
Fig. 8 – correct adjustment of the drawbar



SHORT SETTING OF THE LENGTH OF THE TOP THREE-POINT HITCH DRAWBAR (Fig. 9)

When the length of the drawbar is set too short, the machine only stands on the front row of rollers when lowered to the ground. This applies excessive load on the rollers and on the three-point hitch of the machine.

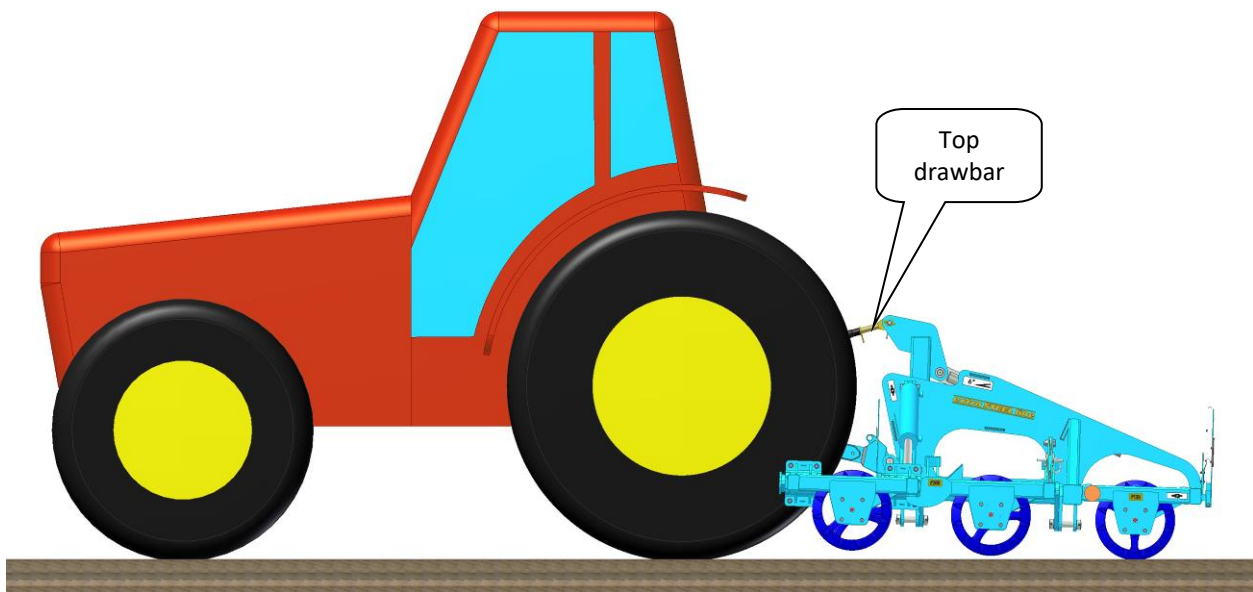
Fig. 9 – short setting of the drawbar



LONG SETTING OF THE LENGTH OF THE TOP THREE-POINT HITCH DRAWBAR (Fig. 10)

When the length of the drawbar is set too long, the machine stands on the rear row of rollers when lowered to the ground. This applies excessive load on the rollers and on the machine frame.


Fig. 10 – long setting of the drawbar



6. MACHINE MAINTENANCE AND REPAIRS

 **Observe the safety instructions for treatment and maintenance.**

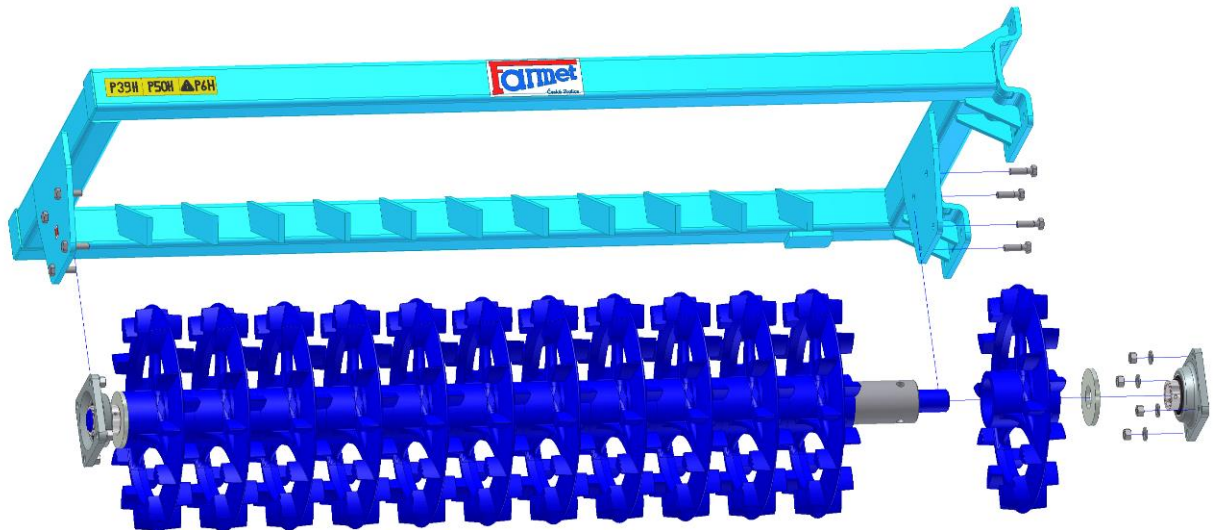
- If it is necessary to weld during the repair and have the machine connected to the tractor, it must have disconnected supply cables from the alternator and the accumulator.
- Check the tightening of all screw and other assembly connections at the machine before every use of the machine, furthermore continuously as needed.
- Continuously check the wear of the working bodies of the machine, possibly replace these worn working bodies with new ones.
- Adjustment, cleaning, and lubrication of the machine may only be performed with the machine at rest (i.e. the machine is standing and not working).
- Plants and other residues potentially caught on the shaft by the bearing have to be removed, otherwise the bearing will get damaged.
- When greasing the bearings, observe caution to prevent their damage.
- When working on a lifted machine, use suitable support equipment supported at marked points or at points suitable for that.
- During adjustment, cleaning, maintenance, and repair of the machine, you must secure those parts of the machine that could endanger the operator by falling or another movement.
- For catching the machine during handling using lifting equipment, use only the places marked with self-adhesive labels with the chain sign "—⚙—".
- Upon a failure or damage of the machine, immediately turn off the tractor's engine and secure against restarting, secure the machine against movement ⇒ only then you can remove the failure.
- During repairs of the machine, use exclusively the genuine spare parts, suitable tools and protective equipment.
- Keep the machine clean.

 **Do not clean bearings and hydraulic rollers with a high-pressure cleaner or direct water stream. The seals and bearings are not watertight at high pressure.**

6.1 REPLACING THE WORKING TOOLS

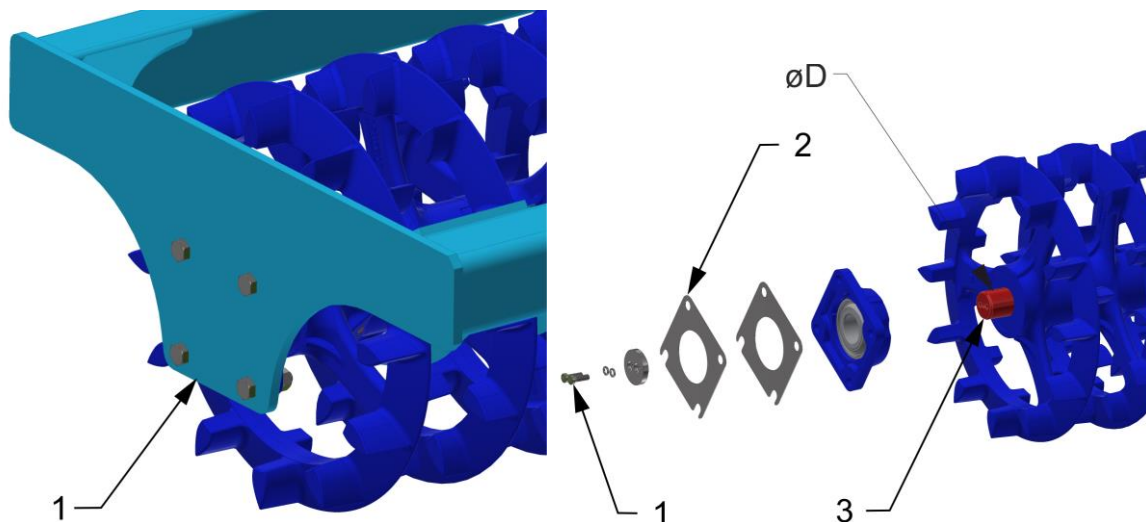
- When replacing worn-and-torn or damaged Crosskill wheels, remove the bearings from the supporting frames of the machine, force them off the roller shaft and replace the old wheels by new ones. Then put the bearings back on the shaft (Fig.11). Then install the roller you have assembled in this way back in the supporting frames.
- All and any replacements of the working tools should be made in a service shop and all the labour-protection rules should be strictly observed.

Fig. 11 – Roller assembly / disassembly



6.2 REPLACEMENT OF THE WORKING ROLLER BEARINGS

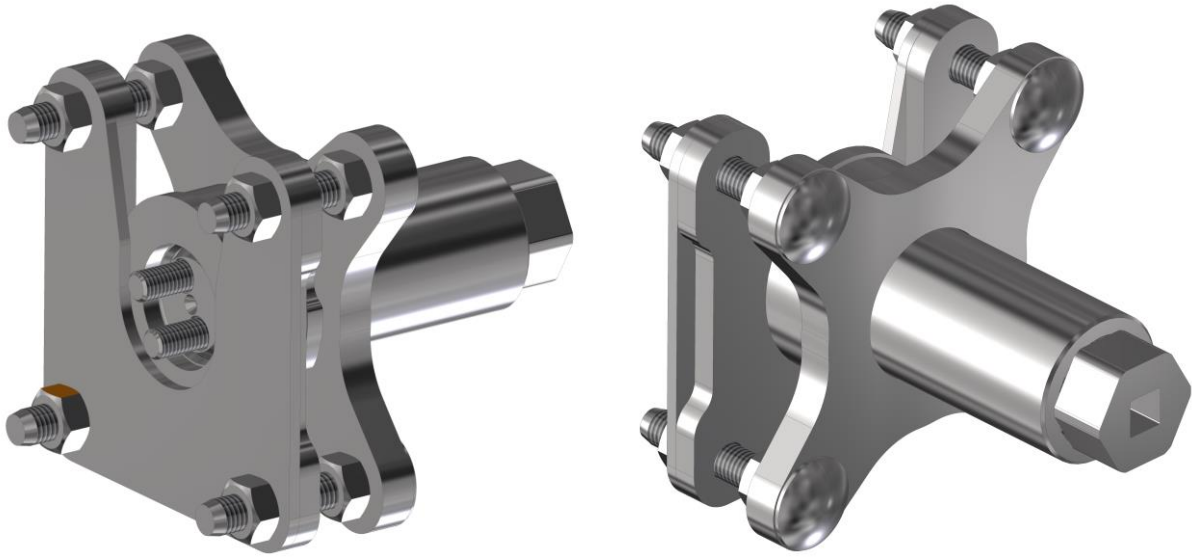
- Always follow the safety regulations and directives when replacing the bearings of rollers.
- The machine must be aggregated with the tractor according to Chapter “3.1” when replacing the bearings. The tractor engine must be switched off for the replacement of bearings and the operator, or repairman, must prevent any access to unauthorised persons to the tractor.
- Only replace the roller bearings on a solid and flat ground and when the machine is in standstill.
- In the case of leaks in the tractor hydraulic system, you are required to provide mechanical supports under the machine drawbar.



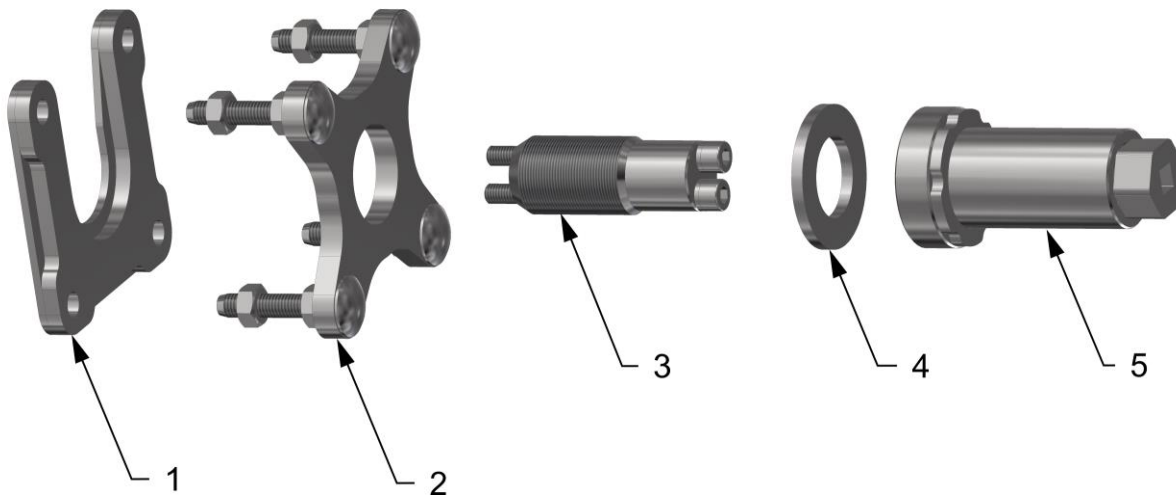
<p>1 – Roller bearing</p>	<p>1 – Bolt 2 – Spacers 3 – Pin cylinder $\varnothing D$ – 40 mm – Bolt M10 (50 Nm) / M8 (20 Nm) $\varnothing D$ – 45 mm – Bolt M12 (86 Nm) / M10 (20 Nm) $\varnothing D$ – 50 mm – Bolt M12 (86 Nm) / M10 (20 Nm) $\varnothing D$ – 60 mm – Bolt M12 (86 Nm) / M10 (20 Nm)</p>
---------------------------	---

6.2.1 USING THE TOOL FOR BEARING DISASSEMBLY AND ASSEMBLY

➤ The tool placed in the box on the machine



Tool parts:

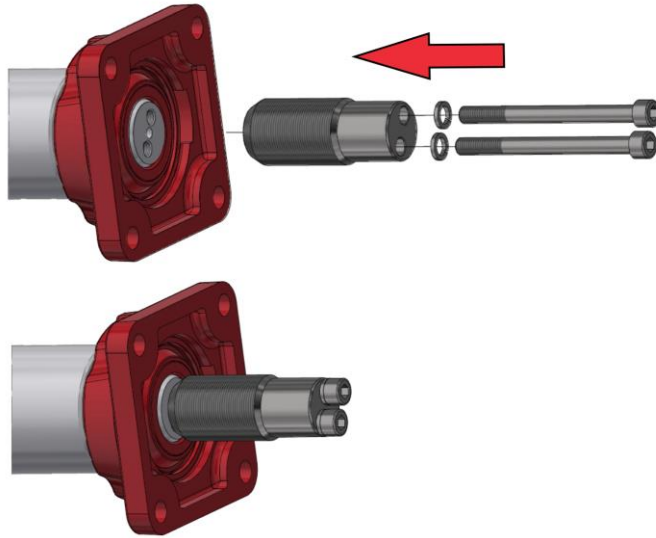


- 1 – Part for disassembling the bearing ring
- 2 – Part for disassembling the bearing or bearing ring
- 3 – Tool pin + bolts
- 4 – Liner
- 5 – Tool body

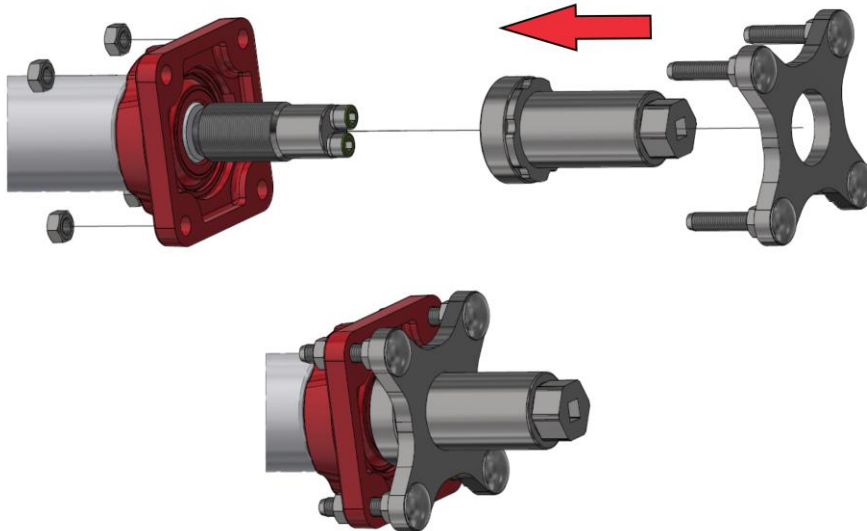
6.2.1.1 COMPLETE BEARING DISASSEMBLY

➤ Procedure:

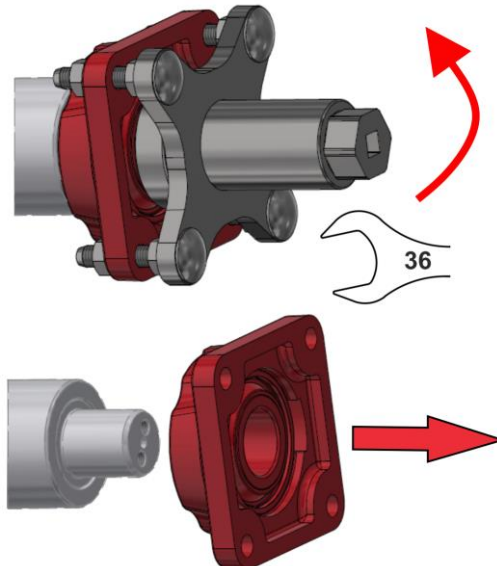
1. Mount and screw the tool pin onto the cylinder pin



2. Screw the tool body in, insert the part for bearing disassembly and mount onto the bearing using the nuts



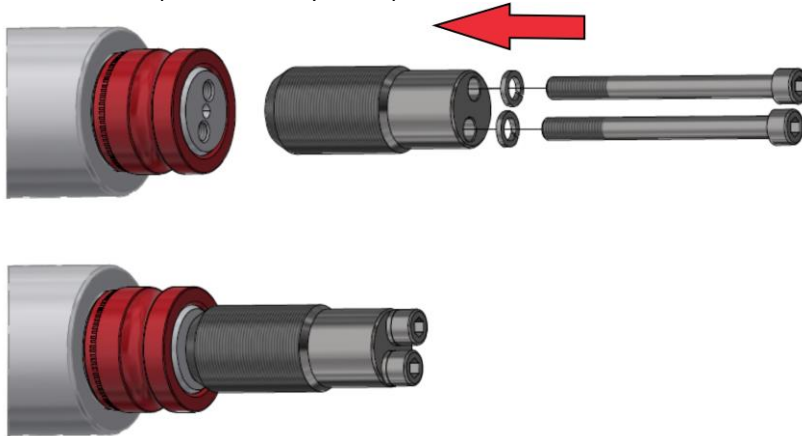
3. Disassemble the bearing by screwing the tool body using spanner size 36



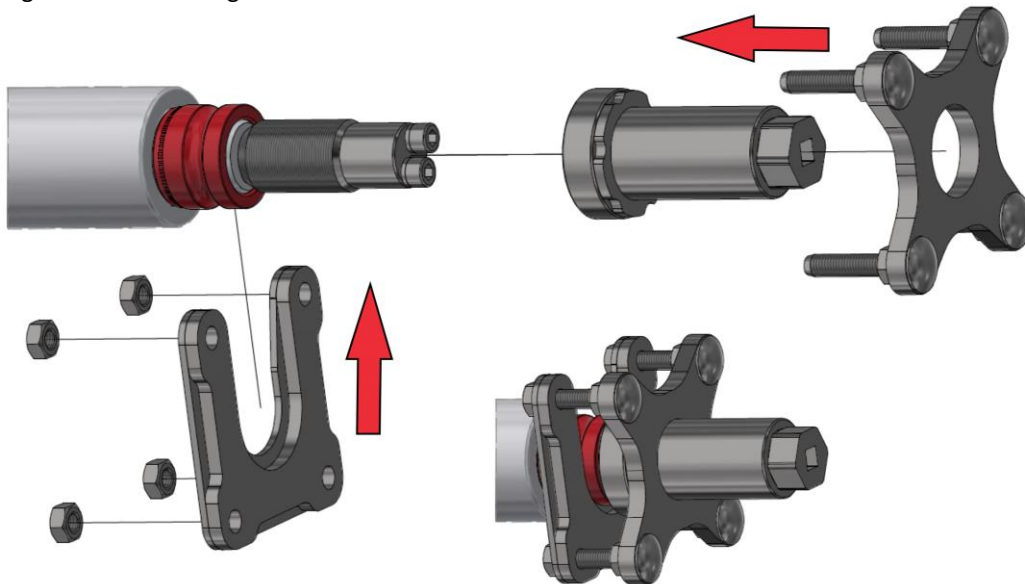
6.2.1.2 DISASSEMBLY OF THE RING

➤ Procedure:

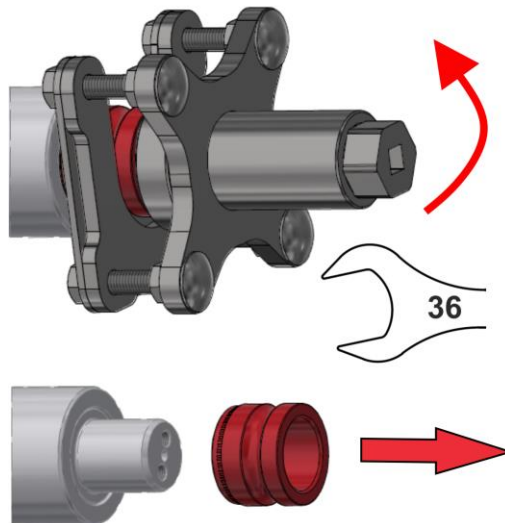
1. Mount and screw the tool pin onto the cylinder pin



2. Screw the tool body, mount the part for disassembling the bearing, mount the part for disassembling the ring and attach it using the nuts



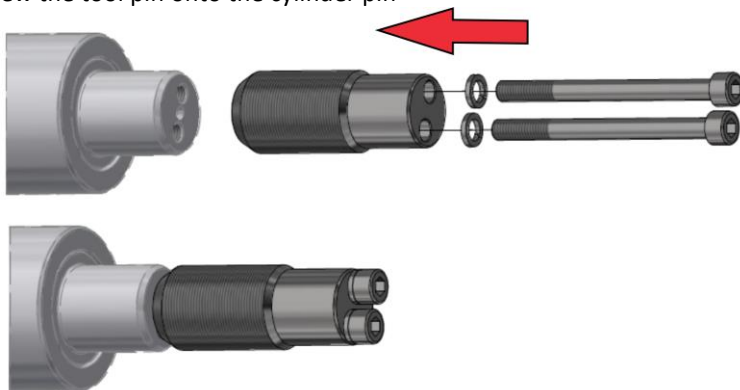
3. Disassemble the ring by screwing the tool body using spanner size 36



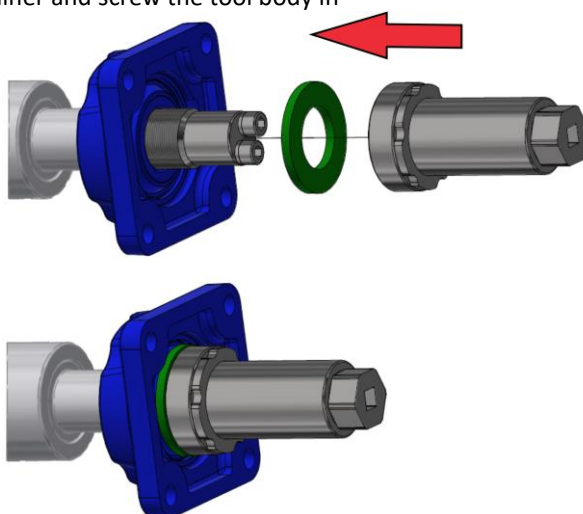
6.2.1.3 ASSEMBLING BEARINGS ONTO PINS

➤ Procedure:

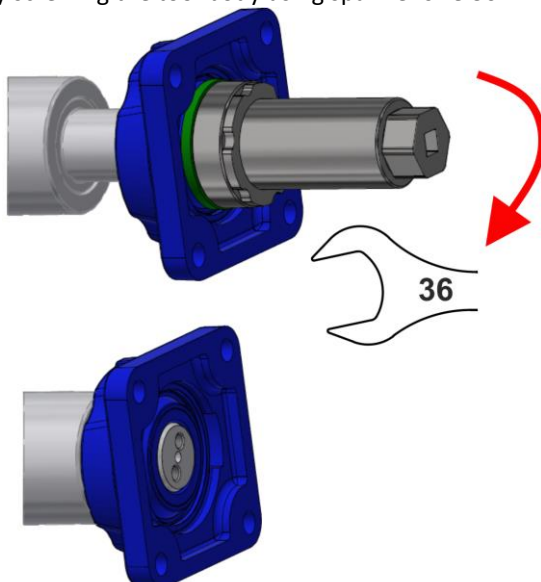
1. Mount and screw the tool pin onto the cylinder pin



2. Mount the bearing + liner and screw the tool body in

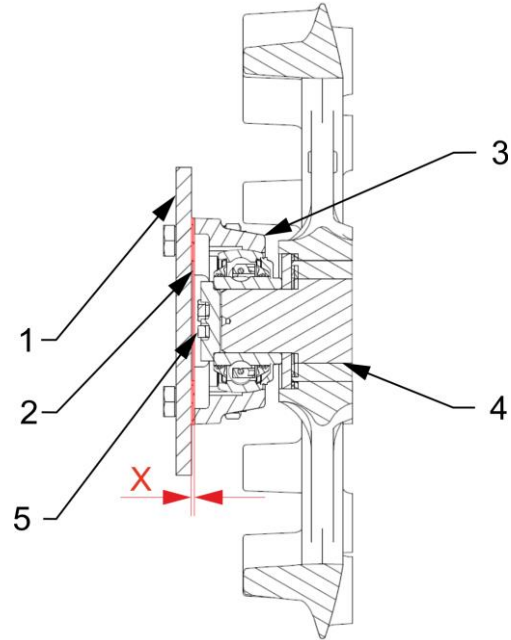
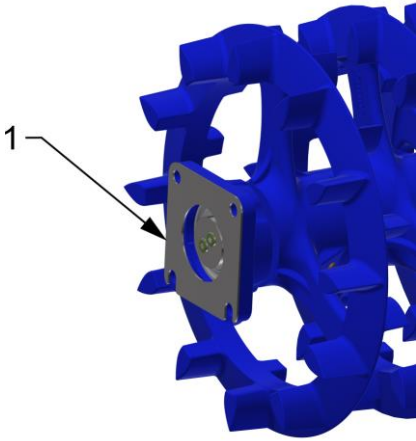


3. Assemble the bearing by screwing the tool body using spanner size 36



6.2.2 USING SPACER

- The spacers are used for defining production tolerances. Therefore, they do not have to be always used.
 - Mount the house bearings to the rollers
 - Insert the roller with the bearings between the frame side plates and assess whether you need to use the SPACERS



1 – Spacers	1 – Side plates 2 – Spacers 3 – House bearing 4 – Pin cylinder 5 – Bolt Parameter "X" = is there a gap? YES = Use spacers NO = Do not use spacers
-------------	---

7. MACHINE STORAGE

Long-term machine shutdown:

- Store the machine under a roof if possible.
- Store the machine on a flat and solid surface with sufficient load capacity, secure it against spontaneous movement.
- Clean the machine before storing and conserve so that it is not damaged in any way during storage.
- Pay special attention to all marked lubrication points and properly lubricate them according to the lubrication plan.
- Store the machine in a folded position, secured with the connecting rod, resting on rollers and support legs, or unfolded, resting on rollers (Fig. 12).
- Secure the machine against access of unauthorised persons.

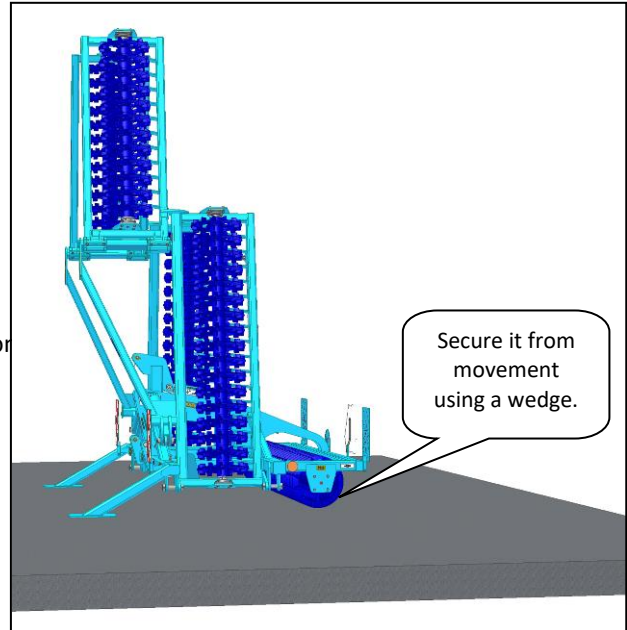
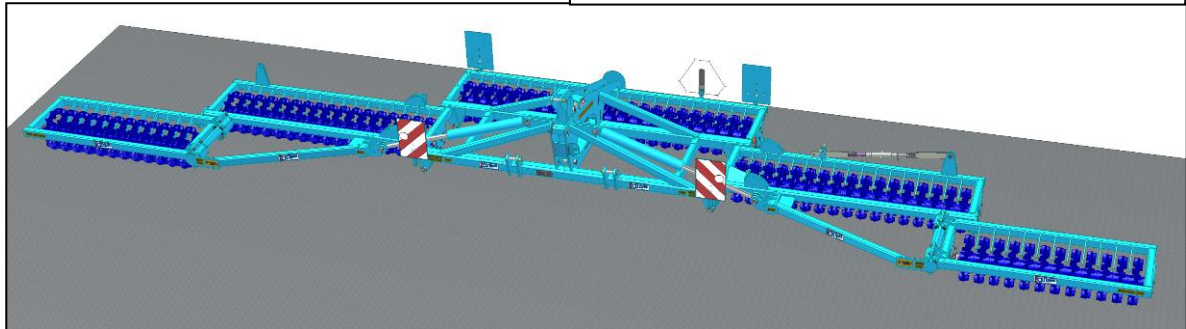


Fig.12 – unfolded machine



8. MACHINE LUBRICATION SCHEDULE

Table 4 – Locations and interval for lubrication of the machine

LUBRICATION POINT		INTERVAL	LUBRICANT
Roller Bearings *	Fig.13	<ul style="list-style-type: none"> - Daily, always before the work with the machine. - Always after the end of works during machine storing. - Always before storing the machine (for a period, when the machine will be stored without work). 	Plastic lubricant based on lithium

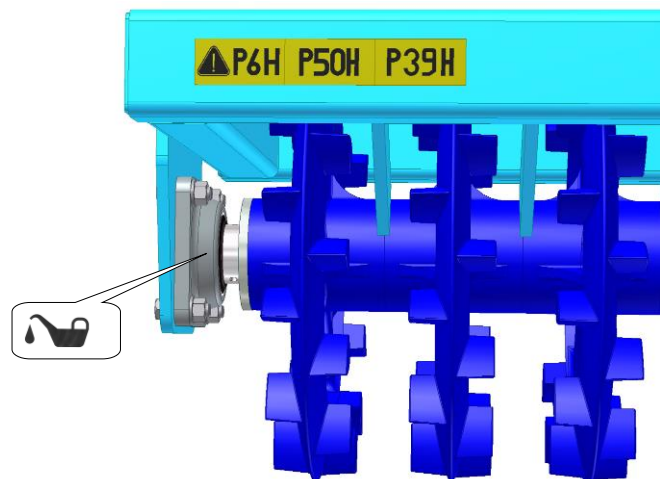
Fig 13 - Roller bearings



Lubricant handling:

Protect yourselves against direct contact with oils by using gloves or protective creams. Thoroughly wash oil spots on the skin using warm water and soap. Do not clean the skin with petrol, engine diesel fuel or other solvents. Oil is poisonous. If you swallowed the oil, immediately seek a physician.

- Protect the lubricants against children.



9. ENVIRONMENTAL PROTECTION

- Check tightness of the hydraulic system regularly.
- All the hydraulic hoses and the other parts of the hydraulic system showing signs of damage should be replaced or repaired.
- Remember that the service life of the hydraulic hoses includes their storage time before they were used.
- Dispose the used lubricants according to the related regulations.

10. MACHINE DISPOSAL AFTER SERVICE LIFE EXPIRY

- The operator must secure during machine disposal that steel parts and parts, in which hydraulic oil or lubricating grease moves are differentiated.
- Steel parts must be cut by the operator while observing safety regulations and handed over to the secondary raw material collection point. He must proceed with other parts according to valid laws about waste.

11. SERVICING AND WARRANTY CONDITIONS

11.1 SERVICING

Servicing is secured by the dealer after consulting with the manufacturer, possibly directly by the manufacturer. Spare parts then using the sales network by individual sellers in the entire country. Use only the spare parts according to the spare parts catalogue officially issued by the manufacturer.

11.2 WARRANTY

- 11.2.1** The manufacturer provides a warranty of 24 months for these machine parts: main frame, axle, and machine tow bar. For other parts of the machine, the manufacturer provides a warranty of 12 months. The warranty is provided from the date of sale of the new machine to the end user (consumer).
- 11.2.2** The warranty applies to hidden defects that will show in the warranty period with proper use of the machine and while fulfilling the conditions stated in the operating manual.
- 11.2.3** The warranty does not apply to wearable spare parts, i.e. regular mechanical wear and tear of replaceable parts of the working sections (shares, edges, etc.).
- 11.2.4** The warranty does not apply to indirect consequences of possible damage, such as service life decrease etc.
- 11.2.5** The warranty is bound to the machine and is not void upon an owner change.
- 11.2.6** The warranty is limited to the disassembly and assembly, possibly replacement or repair of the defective part. The decision, whether to replace or repair the defective part, is up to the contractual workshop of Farmet.
- 11.2.7** During the warranty period, only the authorised servicing technician of the manufacturer may perform repairs or other interventions into the machine. In the opposite case, the warranty will not be acknowledged. This provision does not apply to the replacement of wearable spare parts (see point 11.2.3).
- 11.2.8** The warranty is conditioned by using the genuine spare parts of the manufacturer.

(CZ) ES PROHLÁŠENÍ O SHODĚ
 (GB) CE CERTIFICATE OF CONFORMITY
 (D) EG-KONFORMITÄTSERKLÄRUNG
 (F) DÉCLARATION CE DE CONFORMITÉ
 (RU) СЕРТИФИКАТ СООТВЕТСТВИЯ ЕС
 (PL) DEKLARACJA ZGODNOŚCI WE

1. (CZ) My (GB) We (D) Wir (F) Nous (RU) Мы (PL) My: **Farmet a.s.**
 Jiřínková 276
 552 03 Česká Skalice
 Czech Republic
 DIČ: CZ46504931
 Tel/Fax: 00420 491 450136

(CZ) Vydáváme na vlastní zodpovědnost toto prohlášení. (GB) Hereby issue, on our responsibility, this Certificate. (D) Geben in alleiniger Verantwortung folgende Erklärung ab. (F) Publiions sous notre propre responsabilité la déclaration suivante. (RU) Под свою ответственность выдаем настоящий сертификат. (PL) Wydajemy na własną odpowiedzialność niniejszą Deklarację Zgodności.

2. (CZ) Strojní zařízení: - název : **Drobící válce**
 (GB) Machine: - name : **Crumbling roller**
 (D) Fabrikat: - Bezeichnung : **Zerabbröckelwalzen**
 (F) Machinerie: - dénomination : **Rouleau cassant**
 (RU) Сельскохозяйственная машина: - наименование : **Дробильные катки**
 (PL) Urządzenie maszynowe: - nazwa : **Wały rozdrabniające**

- typ, type : **DV 400C**
 - model, modèle : **DV 400C/10000 NS**
 - (CZ) výrobní číslo :
 - (GB) serial number
 - (D) Fabriknummer
 - (F) n° de production
 - (RU) заводской номер
 - (PL) numer produkcyjny:

3. (CZ) Příslušná nařízení vlády: č.176/2008 Sb. (směrnice 2006/42/ES). (GB) Applicable Governmental Decrees and Orders: No.176/2008 Sb. (Directive 2006/42/ES). (D) Einschlägige Regierungsverordnungen (NV): Nr.176/2008 Slg. (Richtlinie 2006/42/ES). (F) Décrets respectifs du gouvernement: n°.176/2008 du Code (directive 2006/42/CE). (RU) Соответствующие постановления правительства: № 176/2008 Сб. (инструкция 2006/42/ES). (PL) Odpowiednie rozporządzenia rządowe: nr 176/2008 Dz.U. (Dyrektywa 2006/42/WE).

4. (CZ) Normy s nimiž byla posouzena shoda: (GB) Standards used for consideration of conformity: (D) Das Produkt wurde gefertigt in Übereinstimmung mit folgenden Normen: (F) Normes avec lesquelles la conformité a été évaluée: (RU) Нормы, на основании которых производилась сертификация: (PL) Normy, według których została przeprowadzona ocena: ČSN EN ISO 12100, ČSN EN ISO 4254-1.

(CZ) Schválil (GB) Approve by dne: 01.06.2012
 (D) Bewilligen (F) Approuvé
 (RU) Утвердил (PL) Uchwalif

p. Gavlas Dušan
 technický ředitel
 Technical director



Farmet a.s.
 Jiřínková 276
 552 03 Česká Skalice
 DIČ CZ46504931
 3P

V České Skalici dne: 01.06.2012

Ing. Karel Žďárský
 generální ředitel společnosti
 General Manager

