

OPERATING MANUAL

TRITON HEAVY

TRNH 300 P



Edition: 1 | effective from: 1. 9. 2022

Dear customer,

Semi-carried cultivators **TRITON HEAVY** are quality products of Farmet a.s. Ceska Skalice.

You can fully utilise the advantages of your machine after thoroughly studying the operating manual.

The serial number of the machine is punched on the production label and written in the operating manual (see Table 1). This machine serial number must be stated whenever ordering spare parts for possible repairs. The production label is located on the middle frame near the tow bar.

Use only spare parts for these machines according to the **Spare parts catalogue** officially issued by the manufacturer, Farmet a.s. Ceska Skalice.

Possibilities of Use of the Cultivator

The **TRITON HEAVY** cultivator is designed for cultivation of all types of soils up to a processing depth of 400 mm.

Production label of the machine **TRNH 300 P**

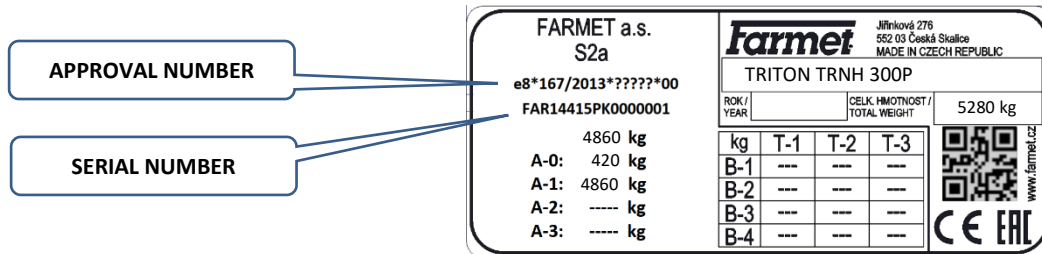

Table 1 – Your Machine Characteristic

MACHINE TYPE	
MACHINE SERIAL NUMBER	
SPECIAL DESIGN OR ACCESSORIES	
.....	
.....	
.....	
.....	

TABLE OF CONTENTS

MACHINE LIMIT PARAMETERS	4
Technical parameters.....	4
Safety statement	5
A. GENERAL INTRUCTIONS FOR USE.....	6
B. MACHINE TRANSPORT USING TRANSPORT MEANS	7
C. MACHINE HANDLING USING LIFTING EQUIPMENT	8
D. WORK SAFETY LABELS	9
1. DESCRIPTION	12
1.1. Machine section arrangement	12
1.2. Working parts	13
1.3. Working without rollers	15
2. HYDRAULICS	16
2.1. Shut off (ball) valve function and position	16
2.2. Hydraulics control panel with two closing valves.....	16
2.3. Description of machine hydraulics	17
2.4. Using the hydraulics control panel.....	19
2.5. Working with the disc and chisel sections	20
3. MACHINE ASSEMBLY AT THE CUSTOMER	21
4. COMMISSIONING	21
5. AGGREGATION TO A TRACTOR	22
6. MACHINE TRANSPORT ON ROADS.....	23
6.1 Scharp machine projection.....	25
7. MACHINE ADJUSTMENT.....	26
7.1. Working depth adjustment	26
7.2. Adjusting the levelling discs	30
7.3. Adjusting side deflectors	31
7.4. Edge levelling discs	32
8. MACHINE MAINTENANCE AND REPAIRS.....	33
8.1. Checking the accumulator pressure	34
9. MACHINE STORAGE.....	35
10. MACHINE LUBRICATION SCHEDULE	36
11. ENVIRONMENTAL PROTECTION.....	37
12. MACHINE DISPOSAL AFTER SERVICE LIFE EXPIRITY.....	37
13. SERVICING AND WARRANTY CONDITIONS.....	37
ⒸCE Certificate of Conformity	38

MACHINE LIMIT PARAMETERS

- ^(x) The machine is designed for soil cultivation when agricultural soil cultivation. Another type of use exceeding the determined purpose is forbidden.
- ^(x) The machine is only operated by one person - the tractor operator.
- ^(x) Machine operator must not use the machine in a different way, especially:
 - ^(x) Transport of persons and animals on the machine structure,
 - ^(x) Transport of burdens on the machine structure,
 - ^(x) Aggregation of the machine with another towing equipment than stated in Chapter „5./p.22“.

TECHNICAL PARAMETERS

Table 2 – Technical Parameters

PARAMETERS	TRNH 300 P
Working width (mm)	3 000
Transport width (mm)	3 000
Transport height (mm)	1 950
Machine total length (mm)	8 500
Working depth (mm) shares/discs	100-400/60-180*
Number of chisel shares	7
Number of discs	14
Working performance (ha/h)	2,4-3,6
Towing means (kW)	155-260**
Working speed (kph)	8-12
Maximum transport speed (kph)	30
Maximum slope grade (°)	6
Tyre dimensions - transport port	400/70-24, 14PR
Machine weight (kg)	5 280***

*For discs 620 mm, working depth setting is described in detail in Chap.7.1/p.26

**Recommended towing means, the real towing force may significantly vary according to the processing depth, soil conditions, land slope, working body wear and adjustment

***For the heaviest version with a double roller and an additional weight

Weight distribution on the machine during transport

Version with a double roller

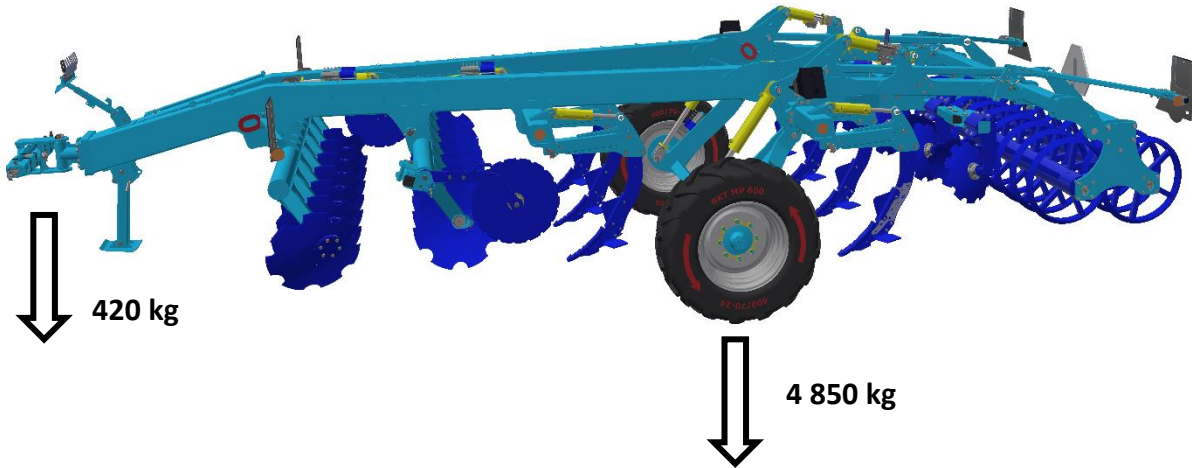

SAFETY STATEMENT

	This warning sign warns about an immediate dangerous situation ending with death or severe injury.
	This warning sign warns about a dangerous situation ending with death or severe injury.
	This warning sign warns about a situation that may end with a smaller or slight injury. It also warns about dangerous actions related to the activity that could lead to an injury.

A. GENERAL INSTRUCTIONS FOR USE

- ^(x) The machine is made in accordance with the latest equipment state and approved safety regulations. However, dangers of user or third person injury or machine damage or creation of other material damage may arise during use.
- ^(xx) Use the machine only in a technically sound condition, in accordance with its purpose, aware of possible dangers, and while adhering to the safety instructions of this operating manual!
The manufacturer is not liable for damages caused by the use of the machine that is in contradiction with the limit parameters of the machine and with the instructions for the use of the machine. The user bears the risk.
Immediately remove especially the failures that may negatively affect safety!
- ⁽⁷⁾ Machine operation may be performed by a ⁽⁸⁾ person authorised by the operator under these conditions:
 - ⁽⁸⁾ It must own a valid driver's licence of the corresponding category,
 - ⁽⁹⁾ It must be demonstrably familiarised with the safety regulations for work with the machine and must practically master the machine operation,
 - ⁽¹⁰⁾ The machine may not be operated by juveniles,
 - ⁽¹¹⁾ It must know the meaning of the safety signs located on the machine. Their respecting is important for safe and reliable machine operation.
- ⁽¹²⁾ Maintenance and servicing repairs on the machine may only be performed by a person:
 - ⁽¹³⁾ Authorised by the operator,
 - ⁽¹⁴⁾ Educated in the machinery field with knowledge of repairs of similar machines,
 - ⁽¹⁵⁾ Demonstrably familiarised with safety regulations for work with the machine,
 - ⁽¹⁶⁾ During a repair of a machine connected to a tractor, it must own a driver's licence of the corresponding category.
- ⁽¹⁷⁾ Machine operator must secure the safety of other persons when working with the machine or transporting the machine.
- ⁽¹⁸⁾ During machine work in the field or during transport, the operator must control the machine from the tractor's cabin.
- ⁽¹⁹⁾ The operator may enter the machine structure only with the machine at rest and blocked against movement, namely only for these reasons:
 - ⁽²⁰⁾ Adjustment of the machine working parts,
 - ⁽²¹⁾ Repair and maintenance of the machine,
 - ⁽²⁹⁾ Release and securing of spherical valves of the axle,
 - ⁽²⁷⁾ Securing of spherical valves of the axle before folding the side frames,
 - ⁽²⁸⁾ Adjustment of the working parts of the machine before work.
- ^(xxx) When climbing on the machine, do not step on the axle tyres, rollers or other revolving parts. Those may turn and you can cause very serious injuries by the subsequent fall.
- ⁽²²⁾ Any changes or modifications of machine may be performed only with written consent of the manufacturer. For possible damage arisen due to ignoring this instruction, the producer bears no responsibility. The machine must be maintained equipped with prescribed accessories and equipment including safety marking. All warning and safety signs must be legible and in their places. In case of damage or loss, these signs must be immediately renewed.
- ⁽²³⁾ The operator must have the Operating Manual with the work safety requirements available at any time when working with the machine.
- ⁽²⁴⁾ The operator must not consume alcohol, medicines, narcotic and hallucinogenic substances that decrease his attention and coordination capabilities while using the machine. If the operator must use medicines prescribed by a physician or uses freely sold medicines, he must be informed by a physician, whether he is capable of responsible and safe operation of the machine under these circumstances.



PROTECTIVE TOOLS

For the operation and maintenance use

- Tight clothes
- Protective gloves and goggles for protection against dust and sharp parts
- of the machine



B. MACHINE TRANSPORT USING TRANSPORT MEANS

- B.1 ⁽¹⁾ The transport means designed for machine transport must have the load capacity minimally identical with the weight of the transported machine. The total weight of the machine is stated on the production label.
- B.2 ⁽²⁾ The dimensions of the transported machine including the transport means must comply with the valid regulations for road traffic (decrees, laws).
-  B.3 ⁽³⁾ The transported machine must be always fastened to the transport means so that its spontaneous loosening could not happen.
- B.4 ⁽⁴⁾ The carrier is responsible for damage caused by the loosening of incorrectly or insufficiently fastened machine to the transport means.
- B.5 ⁽⁵⁾ To fasten the machine, use the recommended points shown in the picture: slings and the central frame of the machine.
- B.6 ⁽⁵⁾ All ball valves must be closed.

PLACE FOR MACHINE FASTENING

- The points for fastening are shown in red

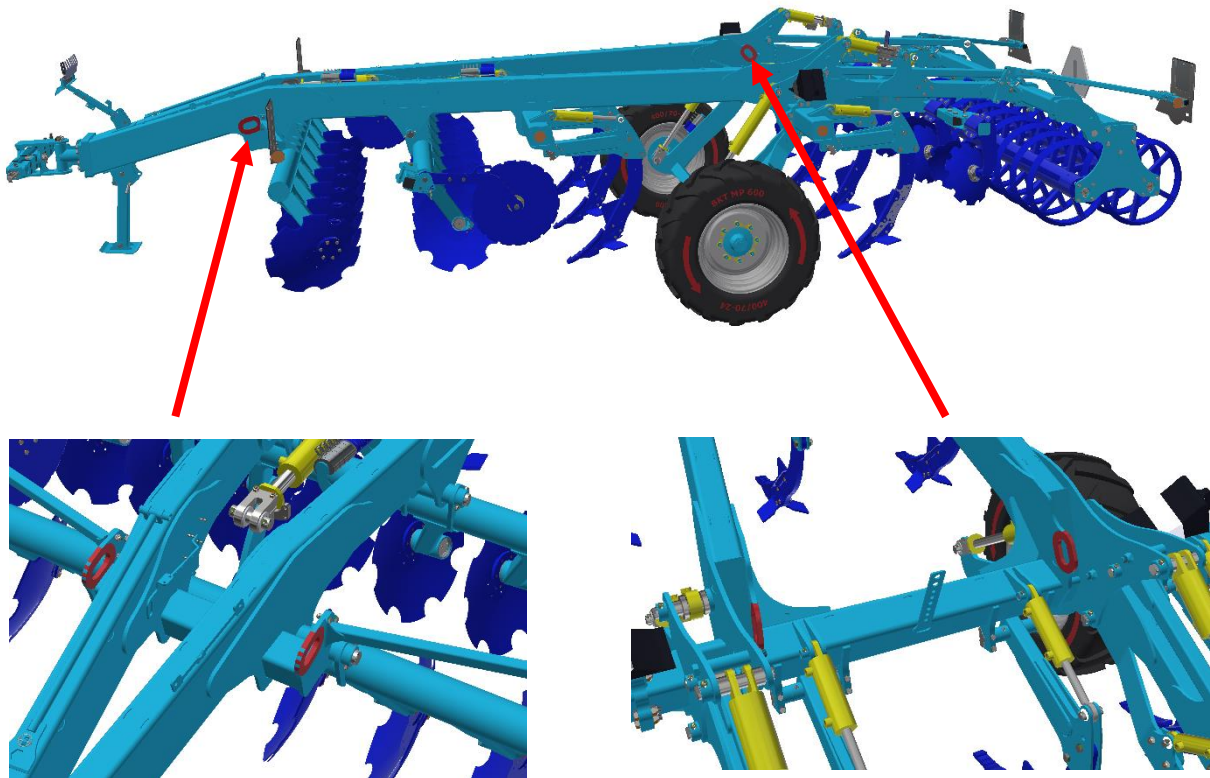

C. MACHINE HANDLING USING LIFTING EQUIPMENT

C.1 ⁽¹⁾ The lifting equipment and tying means designed for handling of the machine must have their load capacity at least identical with the weight of the handled machine.



C.2 ⁽²⁾ Machine fastening for handling may only be performed in places designed for that and marked with self-adhesive labels showing the "chain" symbol. —○—

C.3 ⁽³⁾ After fastening (suspending) at designated points, it is forbidden to move in the space of possible reach of the handled machine.

C.4 ⁽⁴⁾ Do not use the lugs on the roller supports under any circumstances when manipulating with the whole machine. The lugs are only designed for replacing rollers and their maximum load capacity is 500 kg (as shown on the label near the lugs).

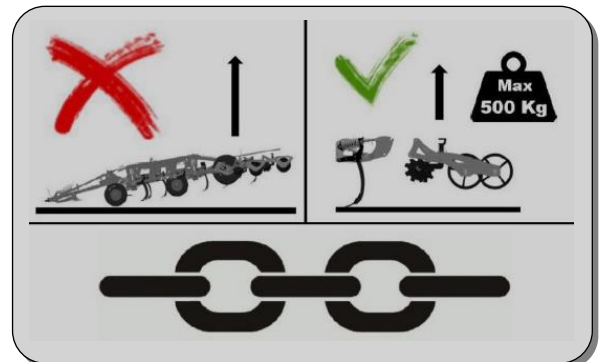

LUGS FOR LIFTING THE MACHINE

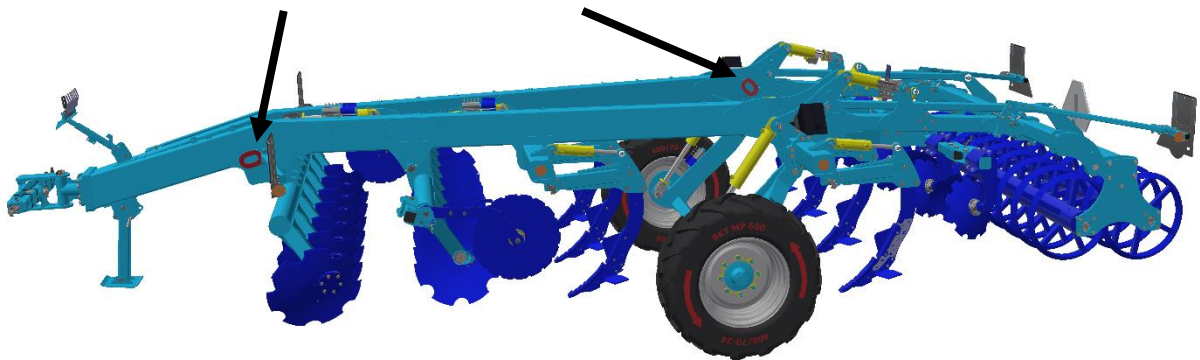

D. WORK SAFETY LABELS

Warning safety labels serve for operator protection.



General:

- A) Strictly observe the warning safety labels.
- B) All safety instructions also apply to other users.
- C) Upon damage or destruction of the aforementioned "SAFETY LABEL" located on the machine, THE OPERATOR IS OBLIGED TO REPLACE IT WITH A NEW ONE!!!

The position, appearance, and precise meaning of work safety labels on the machine is determined in the following tables (Tab. 3) and in the figure (page 11).

Table 3 – Self-adhesive warning safety labels located on the cultivator

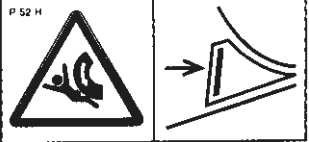
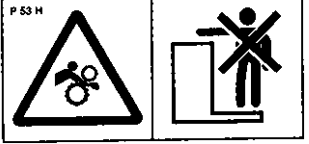
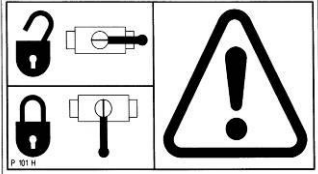
WARNING SAFETY LABEL	LABEL TEXT	MACHINE POSITION
	<p>Before handling the machine, carefully read the operating manual. Observe the instructions and safety regulations for machine operation during use.</p>	P 1 H
	<p>Travelling and transport on the machine structure is strictly forbidden.</p>	P 37 H
	<p>When connecting or disconnecting, do not step between the tractor and the machine, also do not enter this space, if the tractor and the machine are not at rest and the engine is not turned off.</p>	P 2 H
	<p>Stay outside the reach of the tractor - agricultural machine set, if the tractor engine is in operation.</p>	P 6 H
	<p>When folding the side frames, do not reach into the space of the machine folding joints. There is a danger of cutting when setting the depth of the machine.</p>	P 20 H
	<p>Before commencing the machine transport, secure the axle with spherical valves against unexpected drop.</p>	P 13 H
	<p>When working and transporting the machine, maintain safe distance from the electric appliances.</p>	P 39 H

	<p>Secure the machine against unwanted movement by positioning on its working bodies.</p>	<p>P 52 H</p>
	<p>Stay outside the reach of the tractor - agricultural machine set, if the tractor engine is in operation.</p>	<p>P 53 H</p>
	<p>The shown positions of the lever and the function of the hydraulic spherical valve located on the piston rod.</p>	<p>P 101 H</p>
	<p>Before commencing the machine transport, secure the axle with spherical valves against unexpected drop.</p>	<p>P 100 H</p>

LOCATION OF SAFETY LABELS ON THE MACHINE

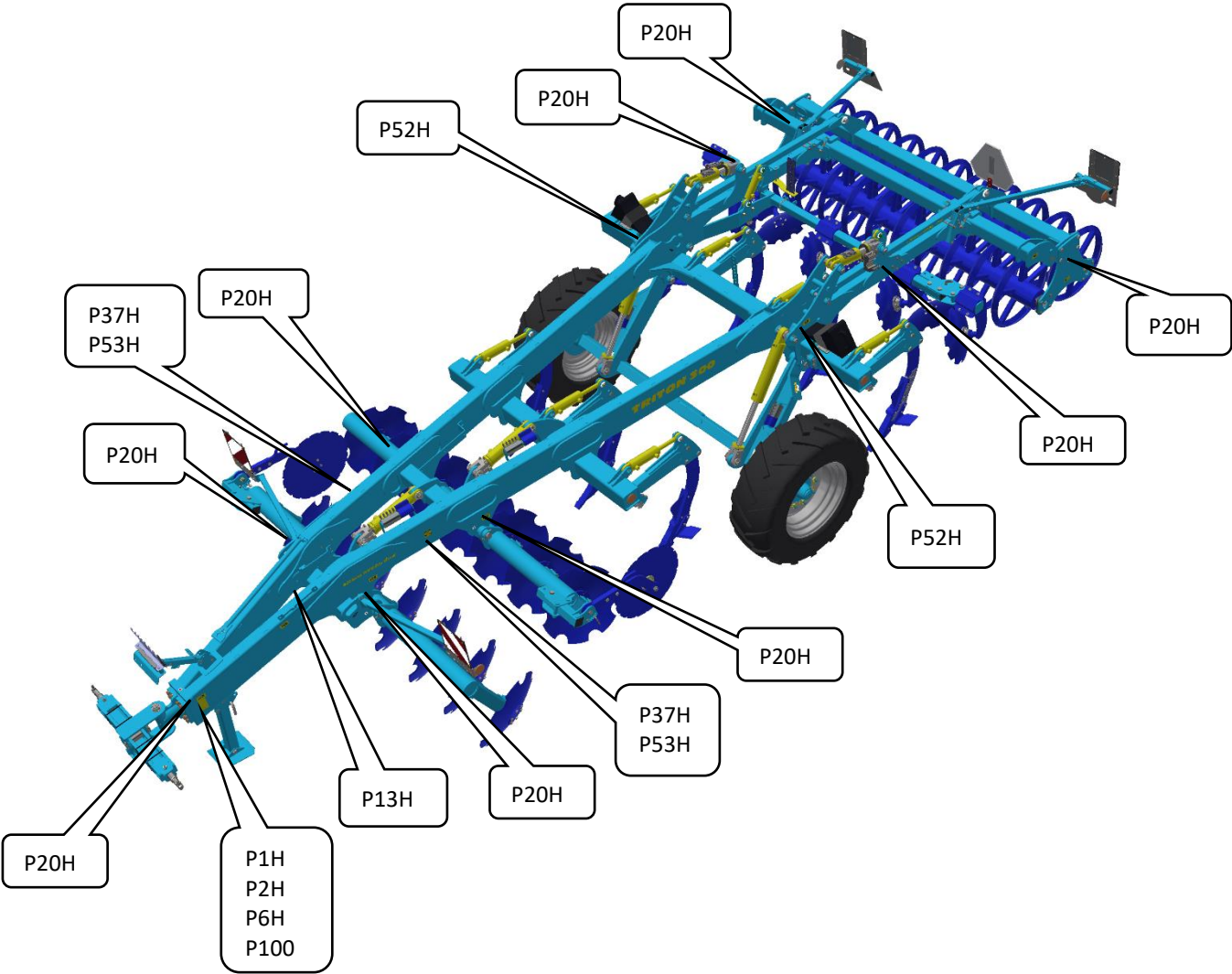

1. DESCRIPTION

The **TRITON 300 P** machine is designed as semi-carried and not folding. The basic version consists of the drawbar, which connects to the pulling vehicle according to the corresponding equipment. Then, there is a central frame with the transport axle and the working section frames. The discs are mounted in two rows on the front part of the central frame. The disc rows are followed with two rows of shares with automatic hydro-pneumatic spring protection. There is a row of levelling discs after the second share row that levels the soil. The last part of the machine consists of rollers that compact the aerated soil.

Basic technological specification of the machine:

- ✓ All-area stubble cultivation after harvest with intense mixing effect
- ✓ Processing soil up to a depth of 40 cm, tillage replacement
- ✓ Excellent incorporation of crop residue into soil.

1.1. MACHINE SECTION ARRANGEMENT

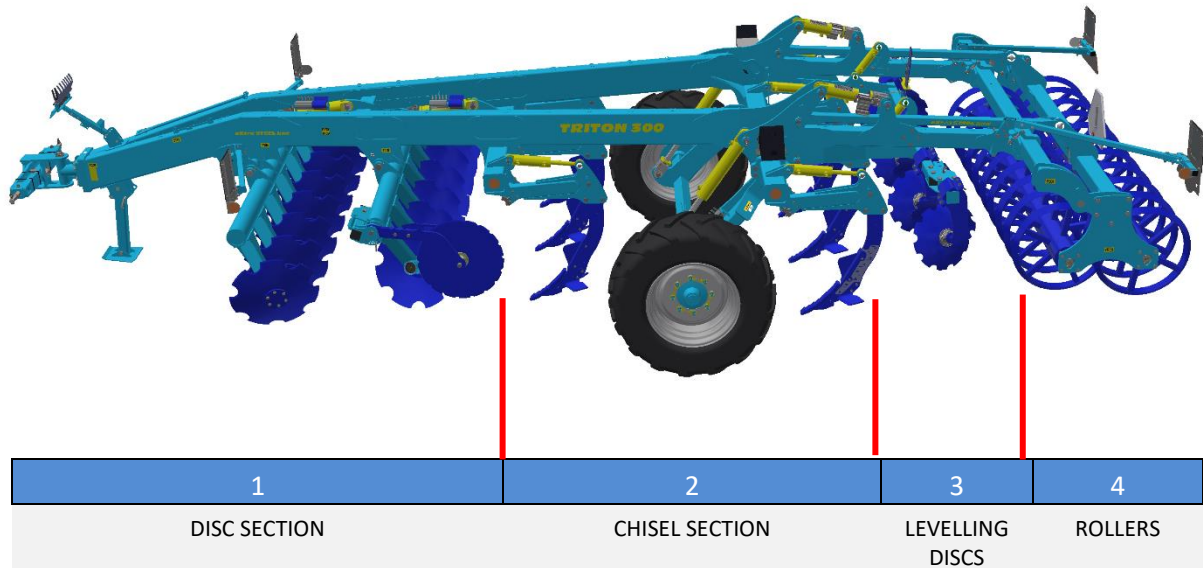

1.2. WORKING PARTS

DISC WORKING UNIT

- Disc diameter 620 mm
- Hydro-pneumatic overload protection of the section
- Release force 2,000 kg
- Massive, welded beam for the row of discs
- Individual Farmet maintenance-free bearing of the individual discs with grease

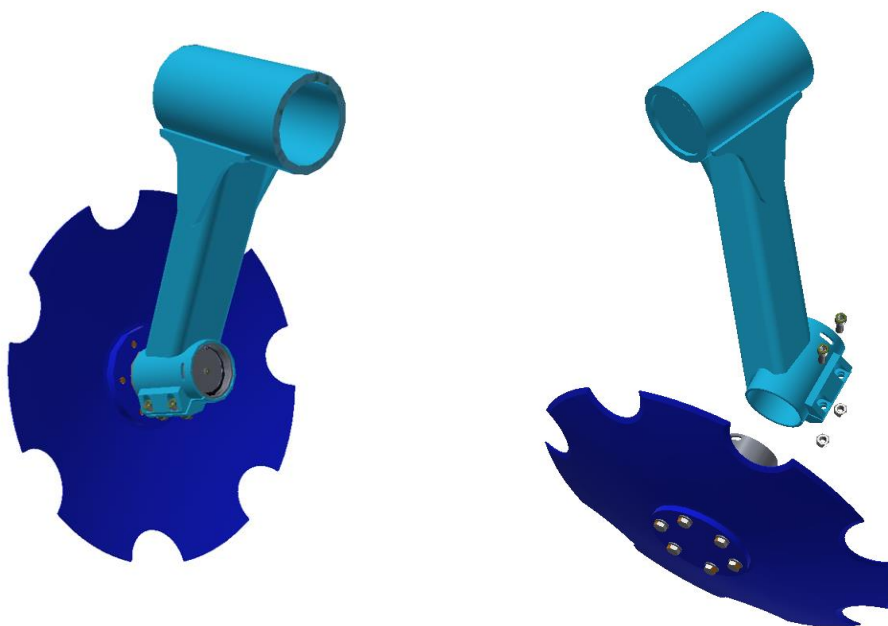

CHISEL WORKING UNIT

- The scope of release of the unit is determined by the piston-rod lift.
- Regularly check pin connections and belts for mounting the main pin of the unit. If there is slackness and the pin turns against the frame, tighten the bolt connection at the prescribed torque ($M12\ 10.9 = 111\text{ Nm}$).
- Regularly check tightening of the nuts in the mounted working components (chisel, wings, mouldboard).

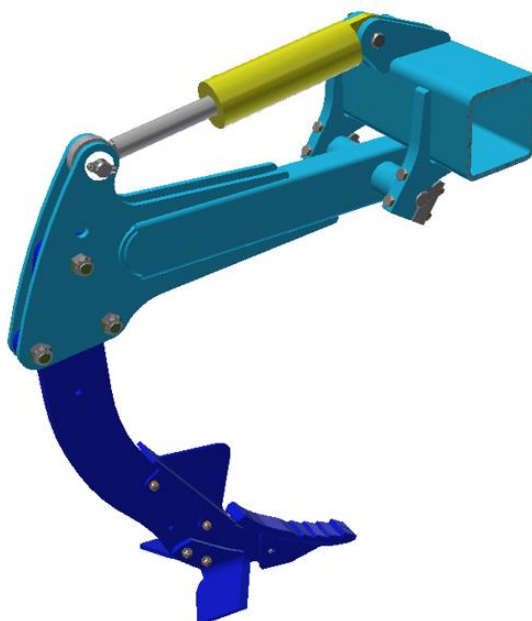

OVERVIEW OF THE WORKING PARTS

CHISEL CARBIDE 55

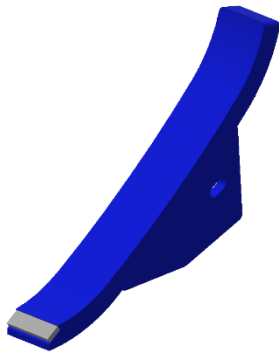

CHISEL CARBIDE 75

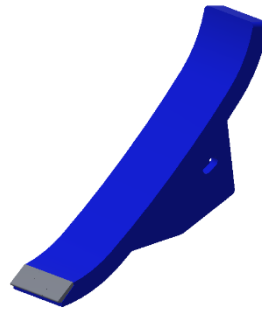

CHISEL MULTICARBIDE PRO 50

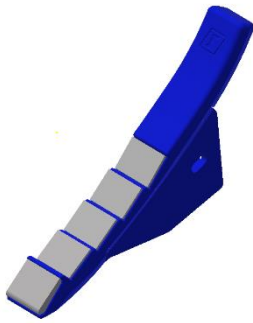

CHISEL MULTICARBIDE PRO 75

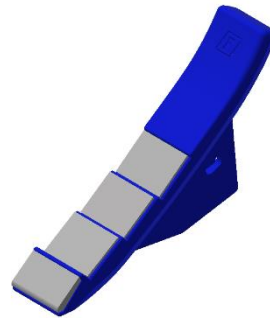

SHARE TOP

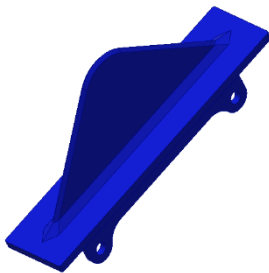

CUTTING WINGS 100 or 135

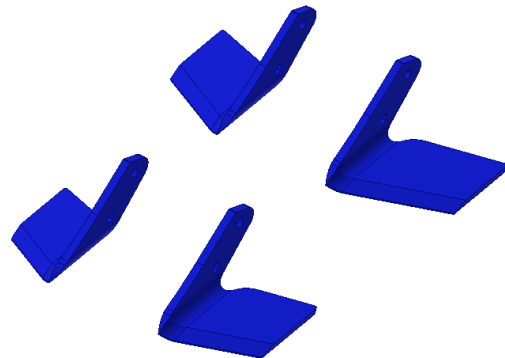

1.3. WORKING WITHOUT ROLLERS

- The machine is designed to be used without the rollers.
- It makes it possible to use the machine when the conditions are wet or when a coarser soil structure is required after cultivation.

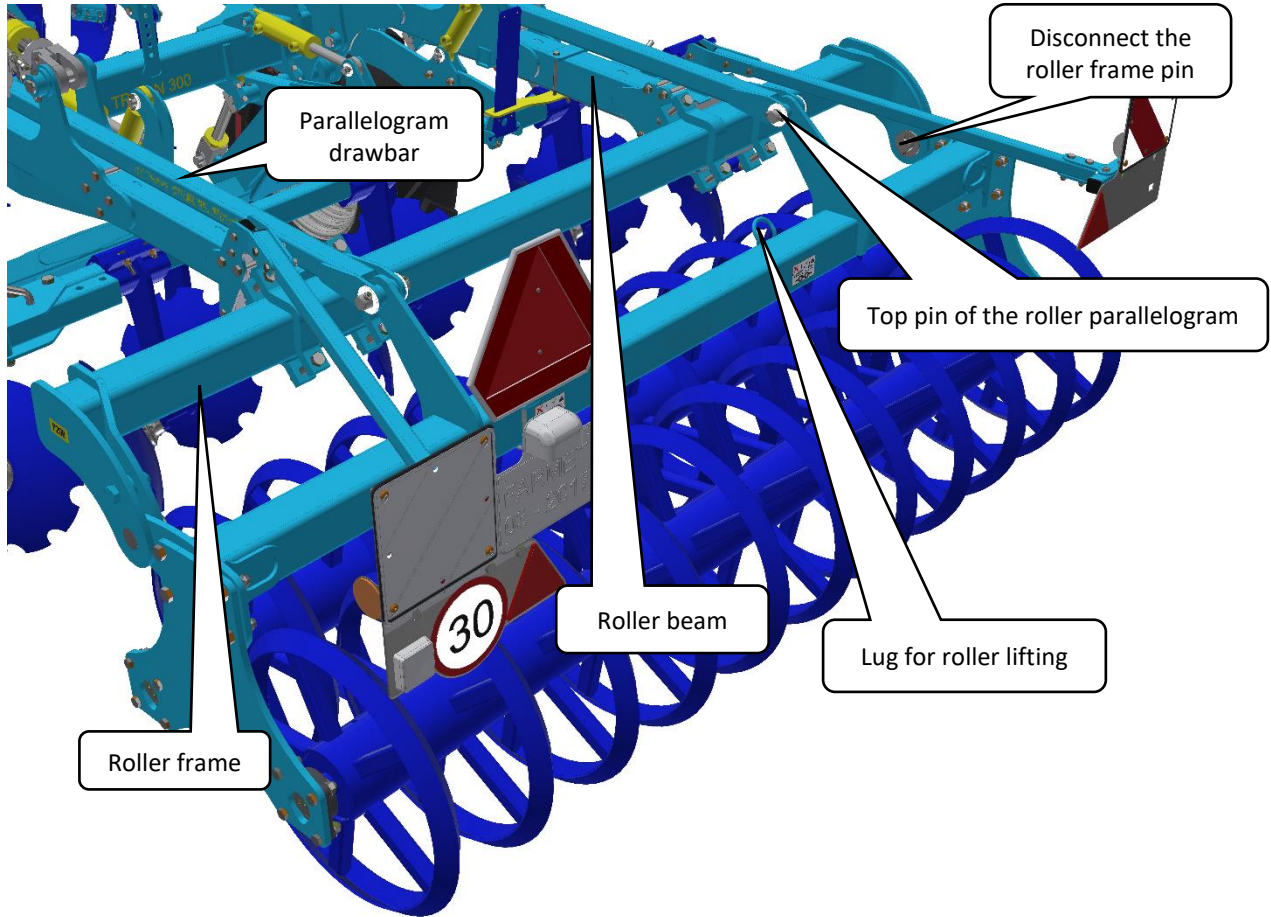

Disconnecting the roller

- 1) Place the rollers on a firm and flat surface.
- 2) Disconnect the top pin of the roller parallelogram.
- 3) Disassemble the pin of the roller frame, the roller frame can be moved hydraulically.
- 4) Carefully drive away from the roller.
- 5) Disassemble the parallelogram drawbar, the machine is prepared for work.

The roller is assembled in a reversed order.

To handle the roller, use the lifting lugs. The roller weighs about 700 kg according to the type.

2. HYDRAULICS

2.1. SHUT OFF (BALL) VALVE FUNCTION AND POSITION

- Shut-off (ball) valves are used in the machine on a well-arranged panel.

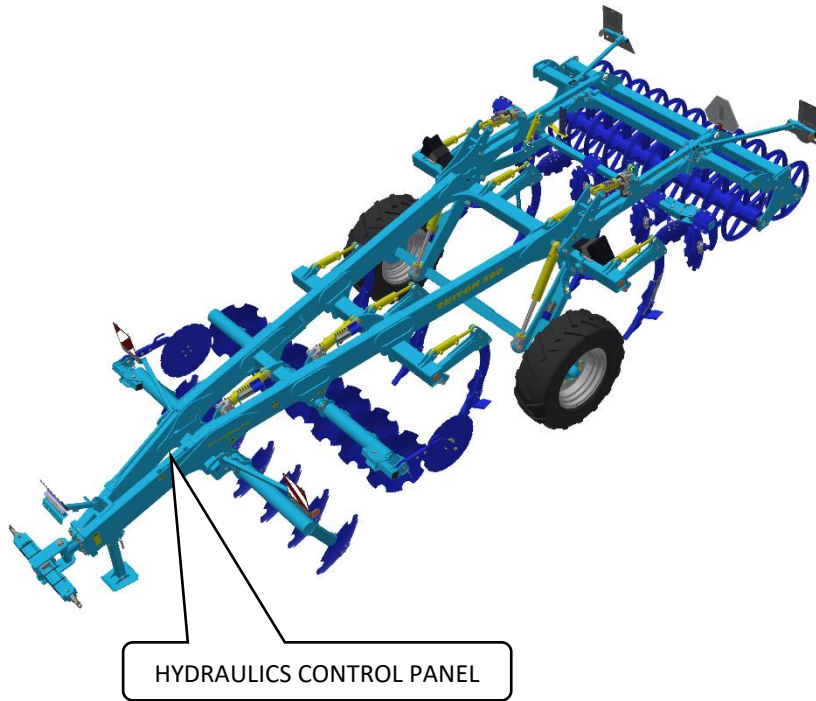

2.2. HYDRAULICS CONTROL PANEL WITH TWO CLOSING VALVES

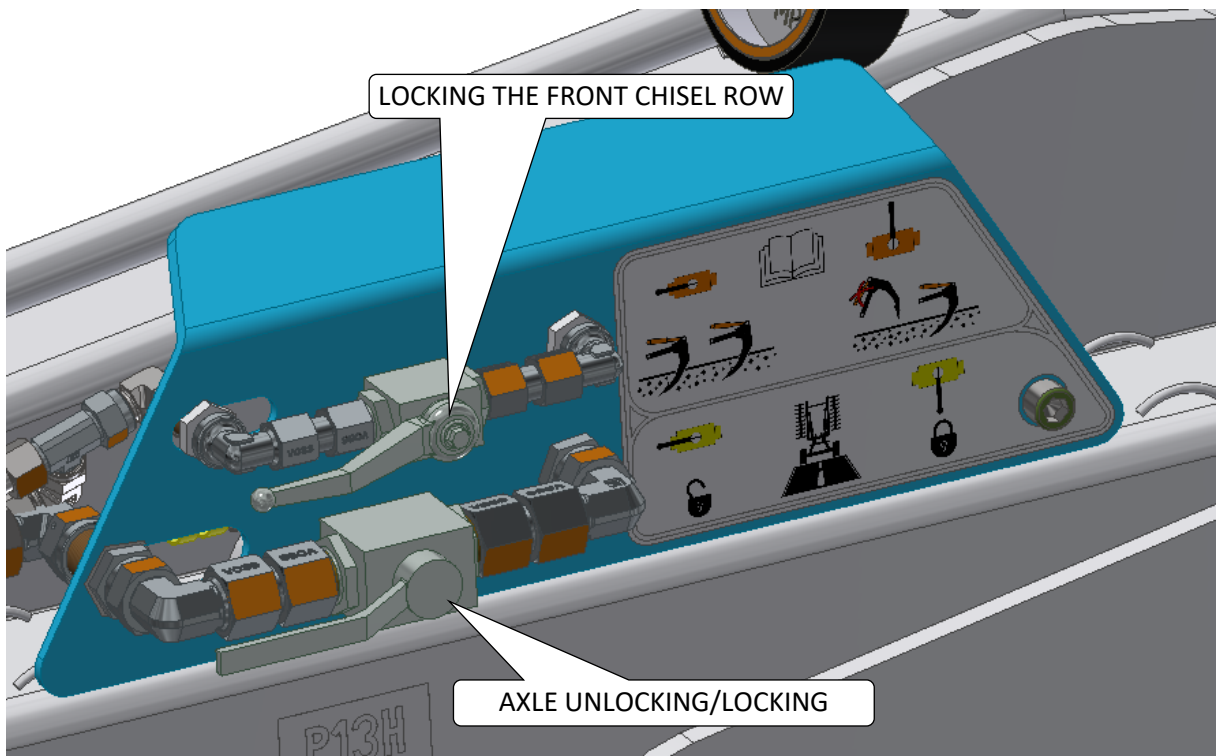

2.3. DESCRIPTION OF MACHINE HYDRAULICS

- When disconnecting the quick couplers, both valves on the drawbar must be closed in the same way as for road transportation.
- Connect the hydraulics only when the hydraulic circuits of the machine and the tractor (aggregate) are in a pressure-less condition.
- The hydraulic system is under high pressure. Regularly check for leaks and immediately remove obvious damage of all lines, hoses, and pipe unions.
- When seeking and removing leaks, use only the suitable tools.
- For connecting the hydraulic system of the machine to the tractor, use the plug (on the machine) and the socket (on the tractor) of the quick couplers of the same type. Connect the quick-couplers of the machine to the hydraulic circuits of the tractor so that the **YELLOW DUST CAPS** for lifting the machine on the axle are on one control circuit, the **GREEN DUST CAPS** for setting the front disc section are on the second control circuit, the **BLUE DUST CAPS** for controlling the rear packer discs are on the third control circuit, and the **WHITE DUST CAPS** for controlling the setting of the working depth of the machine on the rollers are on the fourth control circuit and the **BLACK DUST CAPS** for pressurizing chisel protection are on the fifth circuit.



In order to prevent accidental or foreign person (children, passengers) caused movement of the hydraulics, the control switchboards on the tractor must be secured or blocked in the transport position.

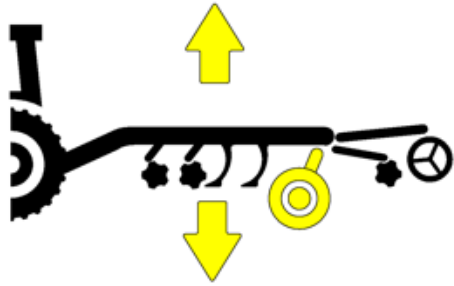

YELLOW DUST CAPS – controlling the transport axle

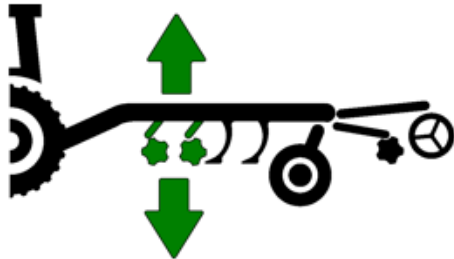

GREEN DUST CAPS – controlling the position of the front disc section

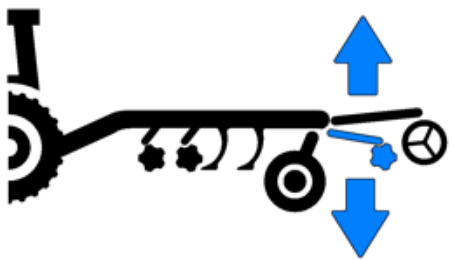

BLUE DUST CAPS – controlling the position of the rear packer discs (supporting legs – when included)

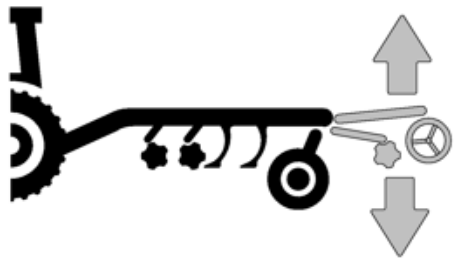

WHITE DUST CAPS – roller position control – machine depth setting

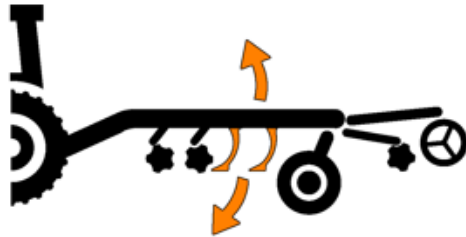

BLACK DUST CAPS – **orange circuit**, hydraulic protection of the chisel units



Parts of the hydraulic system of the machine, which are under pressure, are forbidden to disassemble. Hydraulic oil that penetrates the skin under high pressure causes severe injuries. In case of injury, seek a physician immediately.

2.4. USING THE HYDRAULICS CONTROL PANEL

- There is a control panel with valves (the number of levers may differ according to the machine equipment).
- Changing the levers switch over or close the ball valves in the hydraulic circuits.
- The lever positions according to the pictograms below determine the setting of the hydraulic circuits for the required function of the machine.



When driving on roads, the **YELLOW** circuit valve must be in the closed position.

VALVE FOR LOCKING THE AXLE IN TRANSPORT

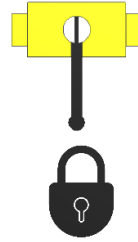
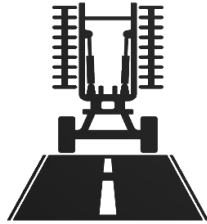
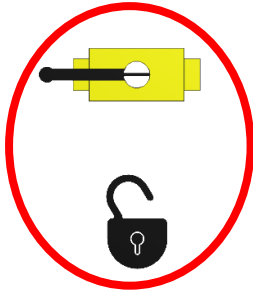

STRAIGHT-WAY VALVE

The machine is in the working position. The **YELLOW** circuit of the axle is open, and the piston- rods can move.

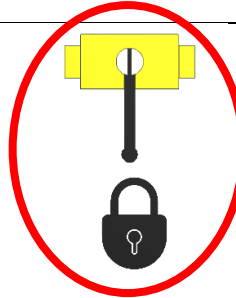
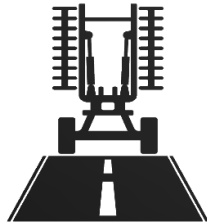
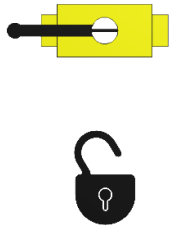

CLOSED VALVE

The machine is in the transport position. The **YELLOW** axle circuit is blocked.

VALVE FOR DEACTIVATING THE FRONT ROW OF THE CHISEL UNITS

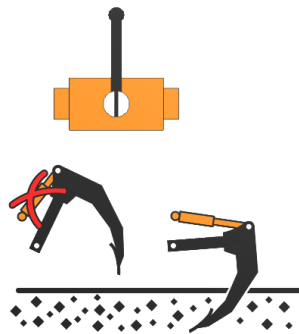
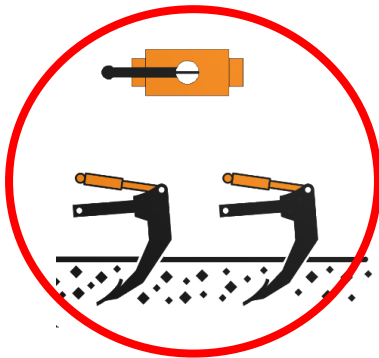

STRAIGHT-WAY VALVE

Both rows of the chisel units are functional and the release force is set by pressurizing the **ORANGE** circuit according to the pressure gauge.

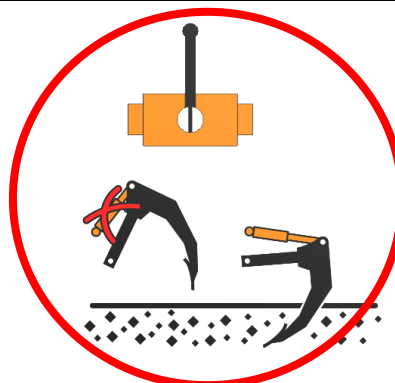
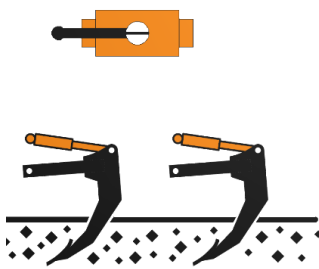

CLOSED VALVE

The front row of the chisel units is blocked. The valve is used for deactivating the front units at the top position to allow working with the rear section only. The rear row must be returned into the working position and the release force pressurized when the front units have been blocked.

2.5. WORKING WITH THE DISC AND CHISEL SECTIONS

- The protection of both rows of discs and chisels is performed using the pressure accumulators.
- The circuits of the hydraulic protection of discs and chisels must be pressurized at the prescribed values.
- The pressure in the system is displayed on pressure gauges, see the picture.
- The pressure does not usually need to be adjusted during work.
- The pressure may temporarily increase on the pressure gauge during work; it is a normal function of release.
- If the pressure exceeds the maximum permitted values, decrease the soil cultivation depth.
- Check the pressure and intactness of the accumulators according to the maintenance plan to ensure the proper function of the protection.
- Both hydraulic circuits must be in the floating position for work (green and orange)

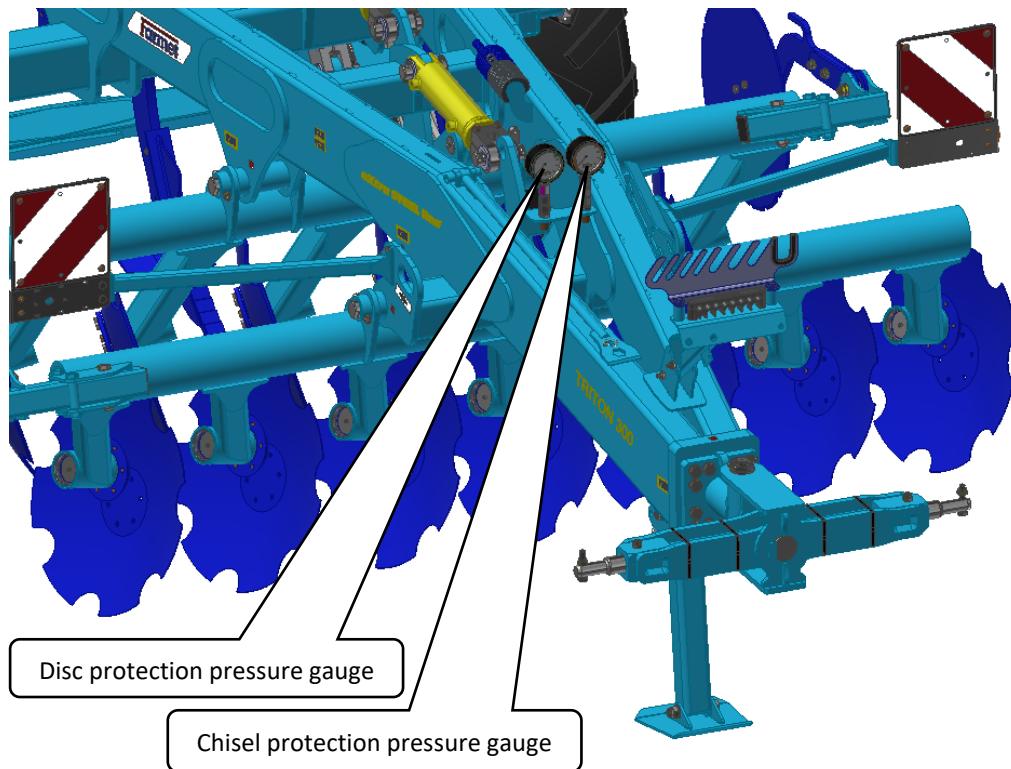

Pressurizing chisel protection

- Before work, set the protection pressure (orange circuit) at 50–75 bar
- High pressure may cause overload or damage the tines and chisels
- At the stated pressure, the protection force of chisels is 750 kg

Pressurizing disc protection

- Before work, set the protection pressure (green circuit) at 180 bar
- High pressure may cause overload or damage the tines and discs
- At the stated pressure, the protection force of discs is 2,000 kg

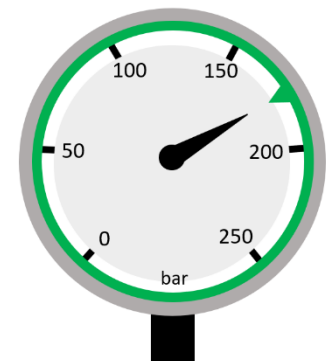
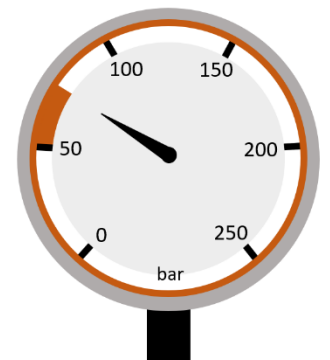

3. MACHINE ASSEMBLY AT THE CUSTOMER

- The operator must perform the assembly according to the instructions of the producer, best in cooperation with the expert servicing technician determined by the producer.
-  ▪ The operator must secure a functional test of all assembled parts after the completion of the machine assembly.
- The operator must secure that the handling of the machine using lifting equipment during its assembly is in accordance with chapter „C“.

4. COMMISSIONING

- Before taking over the machine, test and check, whether damage occurred during transport and whether all parts contained in the bill of delivery were supplied.
-  ▪ Before commissioning the machine, carefully read this operating manual, especially Chapters **A-D**. Before the first use of the machine, familiarise yourselves with its controls and overall function.
- During work with the machine, observe not only the instructions of this operating manual but also generally valid regulations of work safety, health protection, fire and transport safety, and environmental protection.
- The operator must check the machine before every use (commissioning) from the standpoint of completeness, work safety, work hygiene, fire safety, transport safety, and environmental protection. A machine showing signs of damage must not be commissioned.
- Aggregation of the machine with the tractor is to be performed on a flat and hardened surface.
- When working on slopes, observe the lowest slope grade of the set **TRACTOR - MACHINE**.
- Before starting the tractor motor, check whether no person or animal is in the working space of the set and push the warning sound signal.
- The operator is responsible for the safety and all damage caused by the operation of the tractor and the connected machine.
- The operator is obliged to adhere to the technical and safety regulations of the machine determined by the producer when working.
- The operator is obliged to retract the working bodies of the machine from the ground when turning at the headland.
- The operator is obliged to observe the prescribed working depths and speeds stated in the manual in Tabl.2 when working with the machine.
- The operator is obliged to lower the machine to the ground and secure the set against movement before leaving the tractor cabin.

5. AGGREGATION TO A TRACTOR

- The machine can be connected only to a tractor, whose curb weight is identical or higher than the overall weight of the connected machine.
- The machine operator must observe all generally valid regulations of work safety, health protection, fire safety, and environmental protection.
- The operator may connect the machine exclusively to a tractor that is equipped with a rear three-point suspension and a functional undamaged hydraulic system.
- It is possible to use the transport axle with the valve on the drawbar piston rod closed to set the height of the drawbar.
- The table of requirements for the towing means for work with the machine:

Requirement for the tractor engine power for cultivator TRITON TRNH 300 P		155-260 kW
Requirement for the bottom hitch	Bottom hitch	TBZ kat. 3, 4
Requirement for the tractor's hydraulic system	Rear roller depth setting circuit	Circuit pressure 200 bar, 2 pcs of quick-coupler sockets ISO 12,5
	Axle lifting circuit	
	Levelling disc circuit	
	Circuit for lifting the front disc section	
	Chisel protection circuit	



When connecting, no persons may stay in the space between the tractor and the machine.

HYDRAULIC OIL SPECIFICATIONS

The hydraulic circuit of the machine is filled with oil at the factory:

Performance level: API GL 5; SAE 10W-30; SAE 80

Manufacturer's specification: ALLISON C4; CATERPILLAR TO-4; VOLVO VCE WB 101; 97303 JONH DEERE 20C/20D ZF TE-ML 03E/05F/06E/06F/06K/17E/21F; PARKER

DENISON HF-0/HF-1/HF-2 New HOLLAND NH 420A/410B MASSEY FERGUSON M1135/M1141/M1143/M1145 KUBOTA UDT Fluid CASE IH MS-1204/MS-

1206/ MS-1207/MS-1209 FORD M2C134D M2C86B/C CNH MAT 3525/ MAT3526 SPERRY VICKERS/EATON M2950S, I-280-S SAUER

SUNDSTRAND(DANFOSS) Hydro Static Trans fluid; CASE CNH MAT 3540(CVT), Claas (CVT), AGCO CVT; ML200, Valtra G2-10(XT-60+)

6. MACHINE TRANSPORT ON ROADS



Transport position of **TRITON TRNH 300 P**

- Connect the machine by attaching it to the tractor.
- Lift the machine up on the axle, move the lever for locking the machine on the hydraulics control panel into the locked position for transport.
- The machine must be equipped with removable shields with marking of contours, functional lighting, and the board of the rear marking for slow vehicles (according to ECE No. 69).
- The lighting must be activated during travelling on roads.
- The tractor must be equipped with a special light device of an orange colour, which must be activated during travelling on roads.
- The maximum transport speed during travelling on roads is **30 kph**.



Checking the nuts on the transport axle

- Use the plastic arrow “Check Point” to check for loose nuts. It promptly shows the condition of the nuts, whether they are loose or not.
- Always check the Check Points before driving.
- When the arrows are not facing one another, the nuts have to be tightened to the required torque and the Check Point arrows have to point against one another as shown in the green picture.

Torque for the axle nuts:

M18x1,5 - 265Nm

M20x1,5 - 343Nm

M22x1,5 - 440Nm

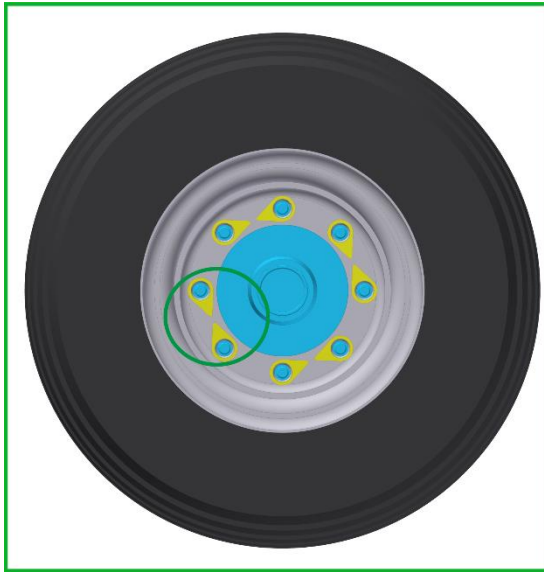

INITIAL POINT-TO-POINT CONFIGURATION

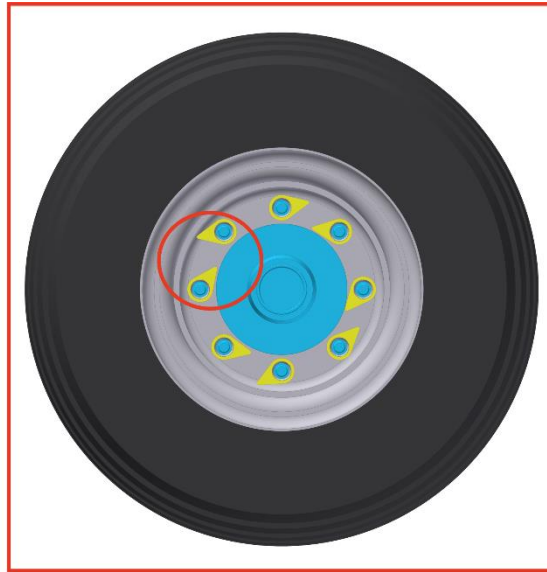

DANGER – WHEEL NUTS HAVE LOOSENED!



Ban of transport with decreased visibility!

- Bring the machine into the transport position.
- The operator is obliged to pay increased attention during transport on roads, due to the transport dimensions of the machine.
- The operator must observe the valid regulations for transport on roads (laws, decrees) after connecting the machine to the tractor, for reason of a change of the axle load. The driving properties of the set also change depending on the terrain nature, adapt the manner of driving to these conditions.
- The operator is obliged to present the machine certificate of roadworthiness as needed, according to the valid regulations for road traffic (decree, law) (only in the Czech Republic).
- The operator is obliged to secure sufficient outlook during reversing from his position of the tractor driver. In case of insufficient outlook, the operator is obliged to call a competent and informed person.
- During machine transport on roads, the operator must observe the valid laws and decrees that deal with this topic and which specify the relationships of the tractor axle load depending on transport speed.

6.1 SHARP MACHINE PROJECTION



- The machine contains sharp structural projections
- **It is prohibited to operate and transport the machine on roads when visibility is reduced!!** - Persons or objects, or other road traffic participants could get caught.
- **The machine operator must be extra cautious when driving on roads and consider the width of the machine and safe distance from persons, vehicles and objects, or other road traffic participants!!**

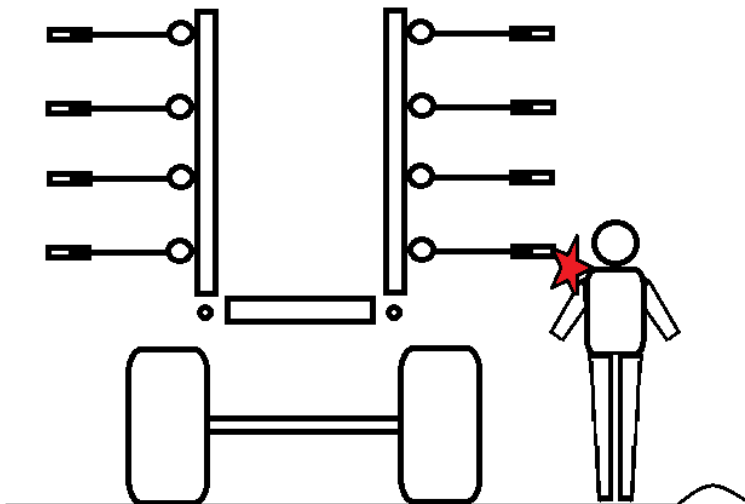

7. MACHINE ADJUSTMENT

7.1. WORKING DEPTH ADJUSTMENT

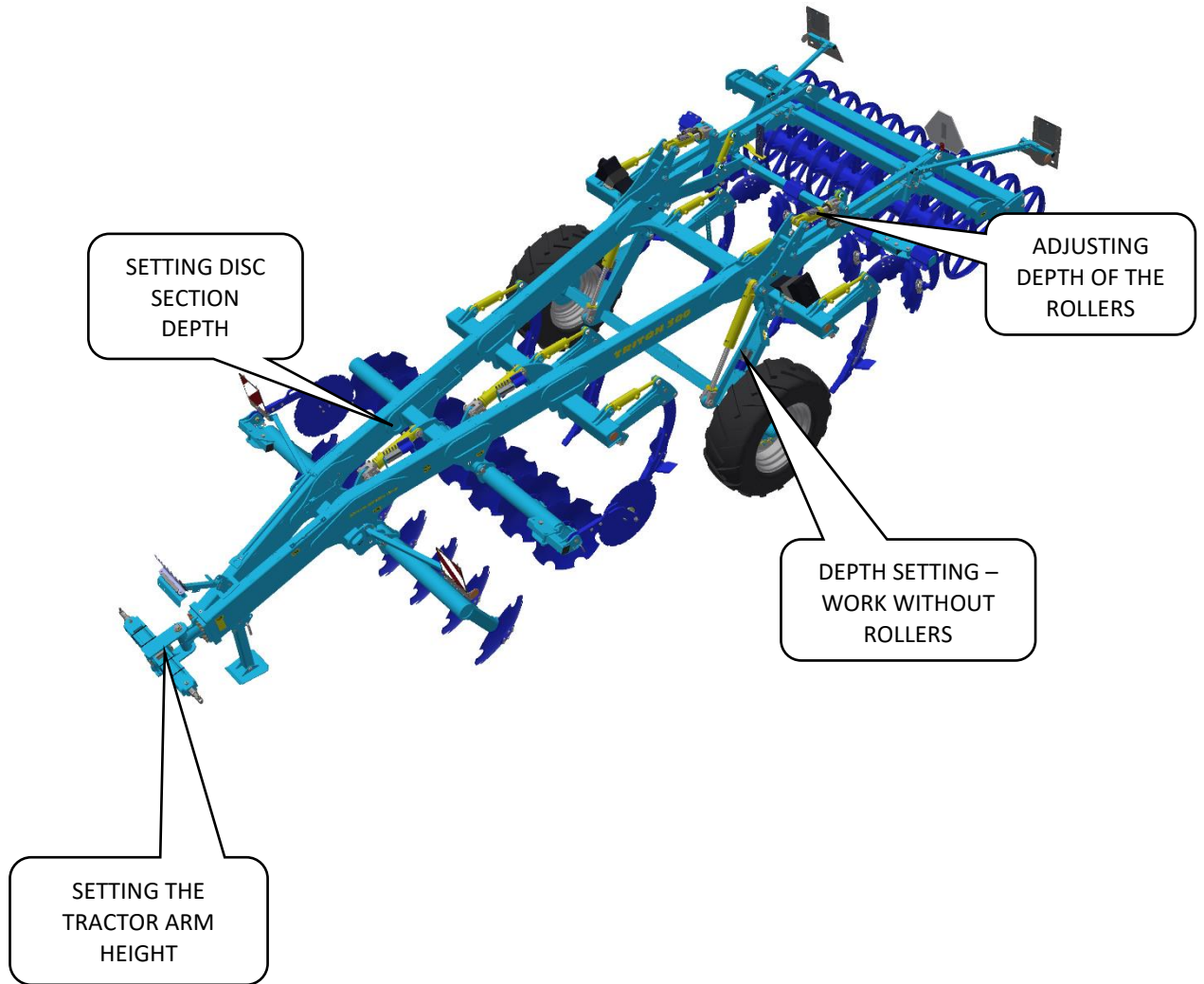

SETTING THE WORKING DEPTH OF THE CHISELS

- The chisel working depth is set by adjusting the height of the machine support frame above ground.
- In the front of the machine, depth is set using the height of the tractor hitch above ground.
- In the rear of the machine, depth is set by the piston-rods of the rollers.
- The machine frame must always be parallel to the ground in order to ensure proper soil cultivation.
- Setting is done by changing the number of spacers or clips on the piston-rods.
- The table states the individual working positions and the number of space washers needed to achieve the required machine depth.
- The stated working depths of the individual positions are for information only. They might differ according to the individual soil conditions. It is possible to add or remove a required number of space washers as needed.
- The working depth of the machine must be set to avoid frequent release of the hydro-pneumatic tine protection. The protection should work only sporadically. The maximum occurrence of release is one tine on the entire machine after 100–200 m of travel. If the release occurs more frequently, reduce the cultivation depth or use narrow chisels. Frequent releasing of the protection may lead to excessive wear of pins and other parts of the protection, requiring more frequent replacements.



The number of the space washers must be the same on all piston-rods!!!

17		10 / 4,5
16		12 / 5,0
15		14 / 5,4
14		16 / 6,1
13		18 / 6,8
12		19 / 7,5
11		21 / 8,2
10		23 / 8,9
9		25 / 10,1
8		26 / 10,3
7		28 / 10,9
6		30 / 11,7
5		32 / 12,4
4		33 / 13,1
3		35 / 13,8
2		37 / 14,5
1		39 / 15,2
0		40 / 15,9

[cm/in]

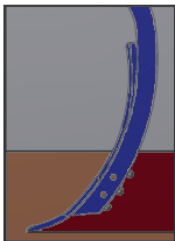

SETTING THE WORKING DEPTH OF THE CHISELS DURING WORK WITHOUT THE ROLLER

- When working without the rollers, the depth can be set using the transport axle.
- Working without rollers is especially convenient when the conditions are wet, or when a coarser soil structure is required, for example, in winter.
- It is forbidden to work on the axle when the rollers are lifted; the rollers must be disassembled for work.
- The depth is set by clips on the axle piston-rods.
- Set the depth according to the sticker on the axle and check the setting during work.
- Removing the small washer (dark blue, 13 mm) increases the working depth by about 30 mm; the large washer (grey, 25 mm) increases the depth by about 55 mm.

Both piston-rods of the axle must have the same number of clips!!!

6 / 2,2
8 / 3,3
11 / 4,3
14 / 5,4
17 / 6,5
19 / 7,6
22 / 8,7
25 / 9,8
28 / 10,9
31 / 12,0
34 / 13,1
37 / 14,2
40 / 15,4

[cm / in]

Examples:

Working at a chisel depth of 25 cm:

1. Set nine washers on both piston-rods of the roller.
2. Set the tractor arms at a position so that the main frame of the machine is horizontal with the ground.

Working with a chisel depth of 17 cm with disassembled rear roller:

1. Place 4 grey clips and 2 blue clips on the piston rods of the transport axle.
2. Set the tractor arms at a position so that the main frame of the machine is horizontal with the ground.

Setting the working depth of the front disc section

- The working depth of the disc section depends on the set depth of the chisels.
- The setting range for the front disc section is 330 mm so that it is possible to cover the range of the working depth of the discs from 60 to 180 mm for all the working depths of the chisel section.
- The working depth of the discs must never exceed **180 mm**.
- The working depth is set by clips on the piston-rods for the disc depth (**GREEN CIRCUIT**).
- Removing the small washer (**blue, 13 mm**) increases the working depth **by about 20 mm**
- Removing the large washer (**grey, 25 mm**) increases the working depth **by about 40 mm**
- To perform the settings, fully eject the piston-rods (**GREEN CIRCUIT**).
- To work, draw the piston-rods into the clip end stop and set the pressure on the pressure gauge at 180 bar.
- When changing the working depth of the chisels, always check the working depth of the disc section.
- Proceed from a smaller working depth to the higher working depth during setting.

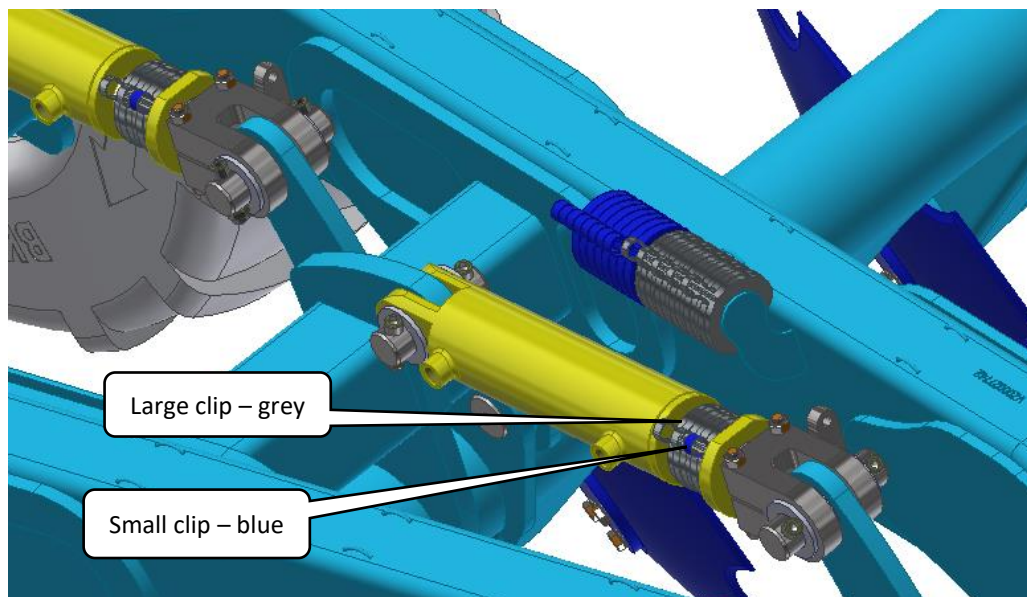

7.2. ADJUSTING THE LEVELLING DISCS

The depth of the levelling discs is set using the hydraulic circuit (BLUE). Be careful when performing the adjustment.

The height setting of the levelling discs can be checked on the indicator as shown in the picture (1 – minimum depth, 3 – maximum depth).

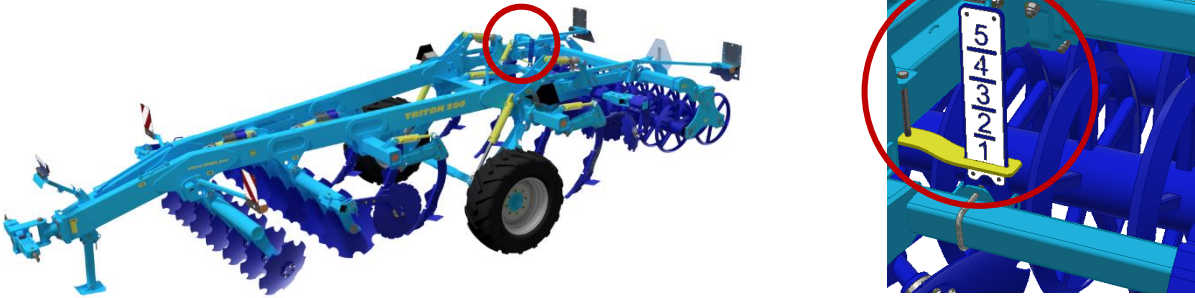

Correctly set discs provide perfect levelling and covering with fine soil along the entire width. When the discs are recessed too low, there are grooves behind the rear shares; when the discs are recessed too deep, there are tracks of collected soil behind the machine. Check the correct disc setting during work – the setting may differ according to the soil conditions and the wear of the discs.

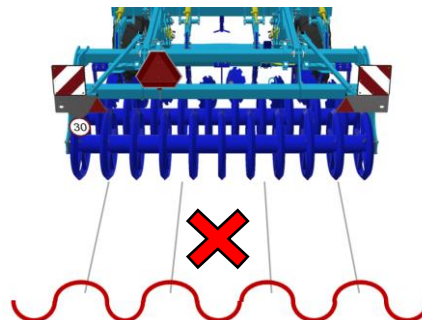
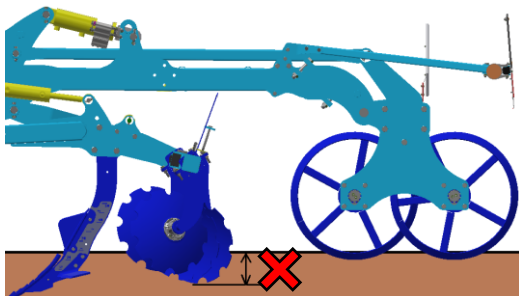
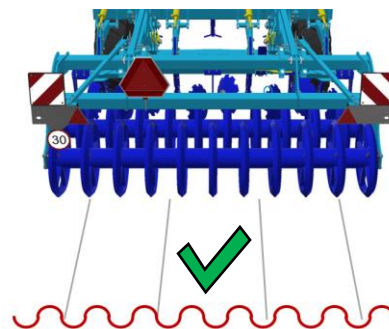
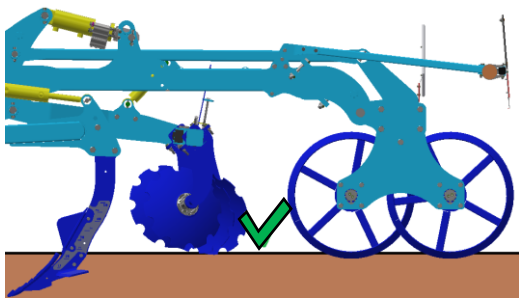
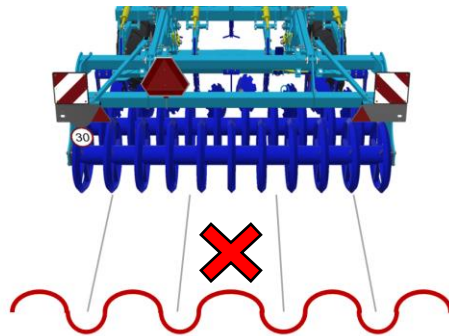
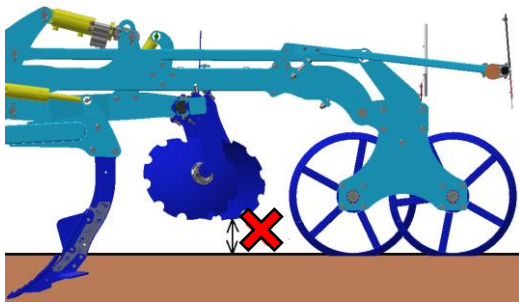

7.3. ADJUSTING SIDE DEFLECTORS

- The side deflectors must be slightly adjusted for proper setting of passes.
- The side deflectors must not exceed the width of 3 metres when travelling on roads.
- After readjusting the deflector, check that there is no collision with the machine frame.
- The setting does not usually need to be changed.

Left deflector

- The deflector consists of a coulter and it keeps soil within the working span of the machine.

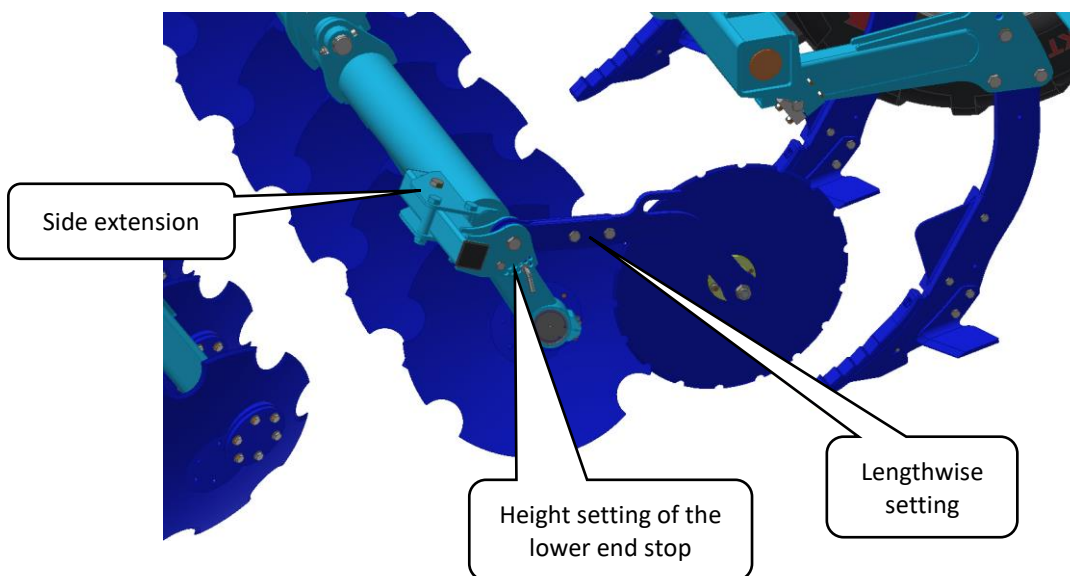

Right deflector

- It moves soil into the groove behind the edge disc.
- The deflector must always be in the inserted (transport) position when travelling on roads.
- It is prohibited to work with the deflector in the transport position.

7.4. EDGE LEVELLING DISCS

- The edge levelling discs must be inserted for transport in order to reach the transport width below 3 metres.
- For work, you can choose one of two working positions according to the specific conditions.
- The levelling discs must not be in the transport position during work; there is a risk of collision with the released tine.

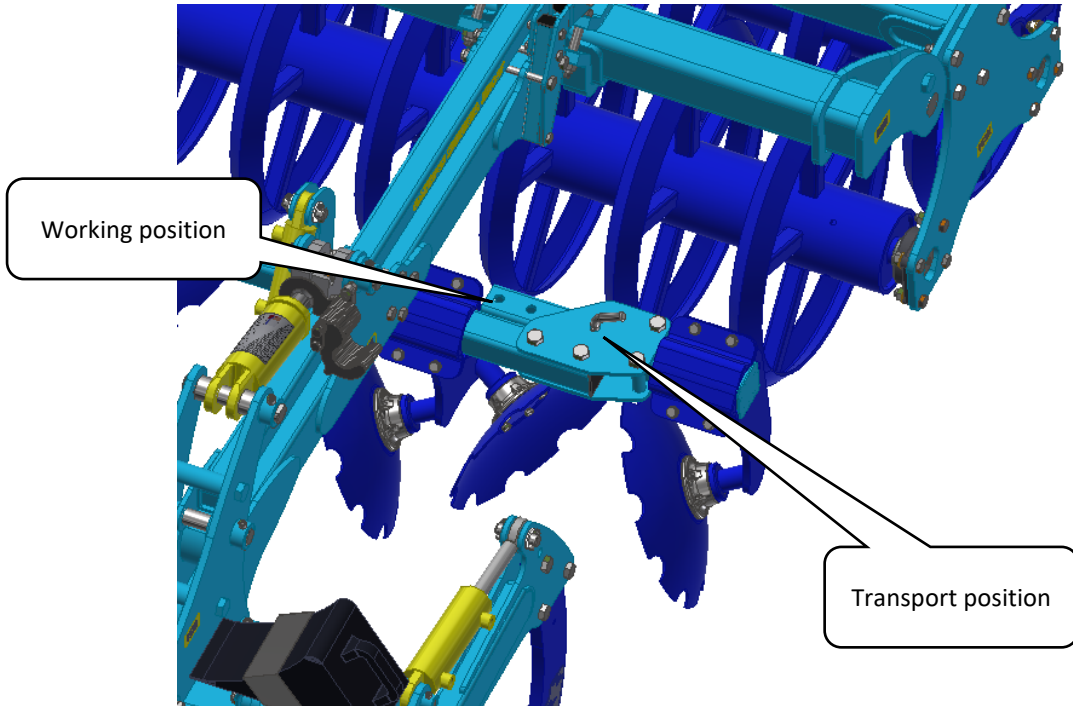

8. MACHINE MAINTENANCE AND REPAIRS



Observe the safety instructions for treatment and maintenance.

- If it is necessary to weld during the repair and have the machine connected to the tractor, it must have disconnected supply cables from the alternator and the accumulator.
- Check the tightening of all screw and other assembly connections at the machine before every use of the machine, furthermore continuously as needed.
- Continuously check the wear of the working bodies of the machine, possibly replace these worn working bodies with new ones.
- Adjustment, cleaning, and lubrication of the machine may only be performed with the machine at rest (i.e. the machine is standing and not working).
- When working on a lifted machine, use suitable support equipment supported at marked points or at points suitable for that.
- During adjustment, cleaning, maintenance, and repair of the machine, you must secure those parts of the machine that could endanger the operator by falling or another movement.
- For catching the machine during handling using lifting equipment, use only the places marked with self-adhesive labels with the chain sign "  ".
- Upon a failure or damage of the machine, immediately turn off the tractor's engine and secure against restarting, secure the machine against movement ⇒ only then you can remove the failure.
- During repairs of the machine, use exclusively the genuine spare parts, suitable tools and protective equipment.
- Regularly check the prescribed pressure in the machine tyres and the condition of the tyres. Perform possible repairs of the tyres in an expert workshop.
- Check the indicator of loose nuts, "Check Point", regularly according to the instructions.
- Keep the machine clean.



Do not clean hydraulic cylinders and bearings with a high-pressure cleaner or direct water stream. The seals and bearings are not watertight at high pressure.

8.1. CHECKING THE ACCUMULATOR PRESSURE

- A proper pressure is required for the proper protection function.
- In case of a pressure loss in the accumulator, the release force quickly increases, the protection is overloaded, which may lead to its damage.
- A pressure too high on the pressure gauges during release indicates a low pressure in the accumulator.
- Contact the Service in case of problems with the pressure accumulators.
- Check the pressure when the hydraulic system is depressurized; the pressure on the pressure gauge is zero.
- Only professionally trained staff may inspect the accumulator pressure and special equipment is required.

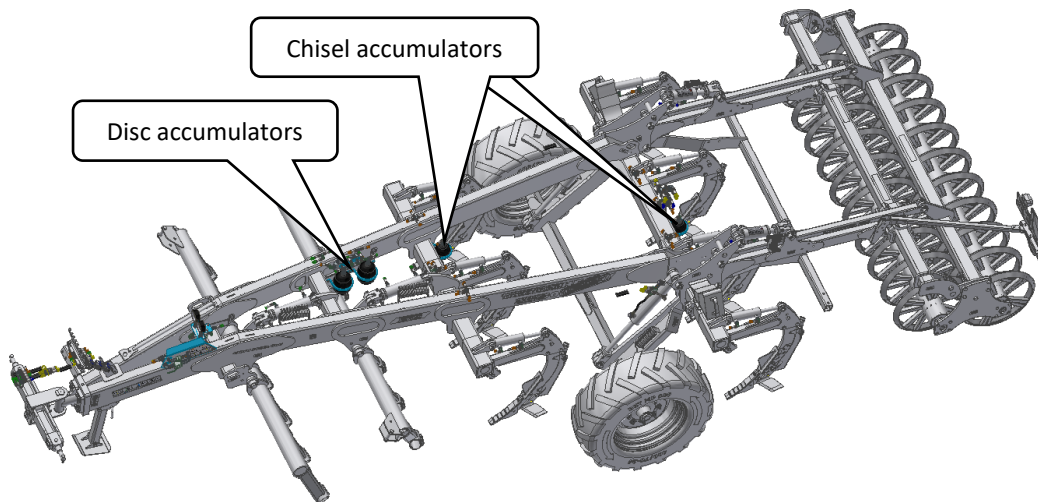

- **PRESSURE VESSEL**
- Never open or adjust (welding, drilling etc.) the pressure vessel (pressure accumulator). The pressure vessel is still under gas pressure even after it has been emptied.
- Empty the pressure vessel in case of any work on the hydraulics of the machine. The manometer must not show any pressure, or the pressure on the manometer must decrease to 0 bars. Only then it is permitted to work on the hydraulic circuit.

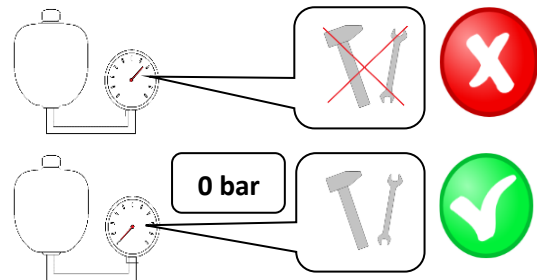

9. MACHINE STORAGE

Long-term machine shutdown:

- Store the machine under a roof if possible.
- Store the machine on a flat and solid surface with sufficient load capacity.
- Clean the machine before storing and conserve so that it is not damaged in any way during storage.
- Park the machine on the axle and on the supporting leg, secure the machine against spontaneous movement using scotch blocks.
- When storing, lower the machine into the lower position using hydraulics.
- **The machine must not rest on the discs and the chisel units.** There is a risk of damage to the working discs or chisel breakage.
- Secure the machine against access of unauthorised persons.

10. MACHINE LUBRICATION SCHEDULE



During machine maintenance and its lubrication, it is necessary to observe the safety regulations.

LUBRICATION POINT	INTERVAL	LUBRICANT
TOW BAR JOINT	<ul style="list-style-type: none"> ▪ Once a week ▪ Always before the work with the machine ▪ Always after the end of the season and before storing the machine 	Grease class NGLI 2 with EP additives
DISC SECTION PINS	<ul style="list-style-type: none"> ▪ Once a week ▪ Always before the work with the machine ▪ Always after the end of the season and before storing the machine 	Grease class NGLI 2 with EP additives
AXLE PINS	<ul style="list-style-type: none"> ▪ Once a week ▪ Always before the work with the machine ▪ Always after the end of the season and before storing the machine 	Grease class NGLI 2 with EP additives

- Points of lubrication are marked:



- When it is difficult to apply the grease into the point of lubrication despite pressing the grease gun lever strenuously, try turning the joint while pressing the grease gun lever.

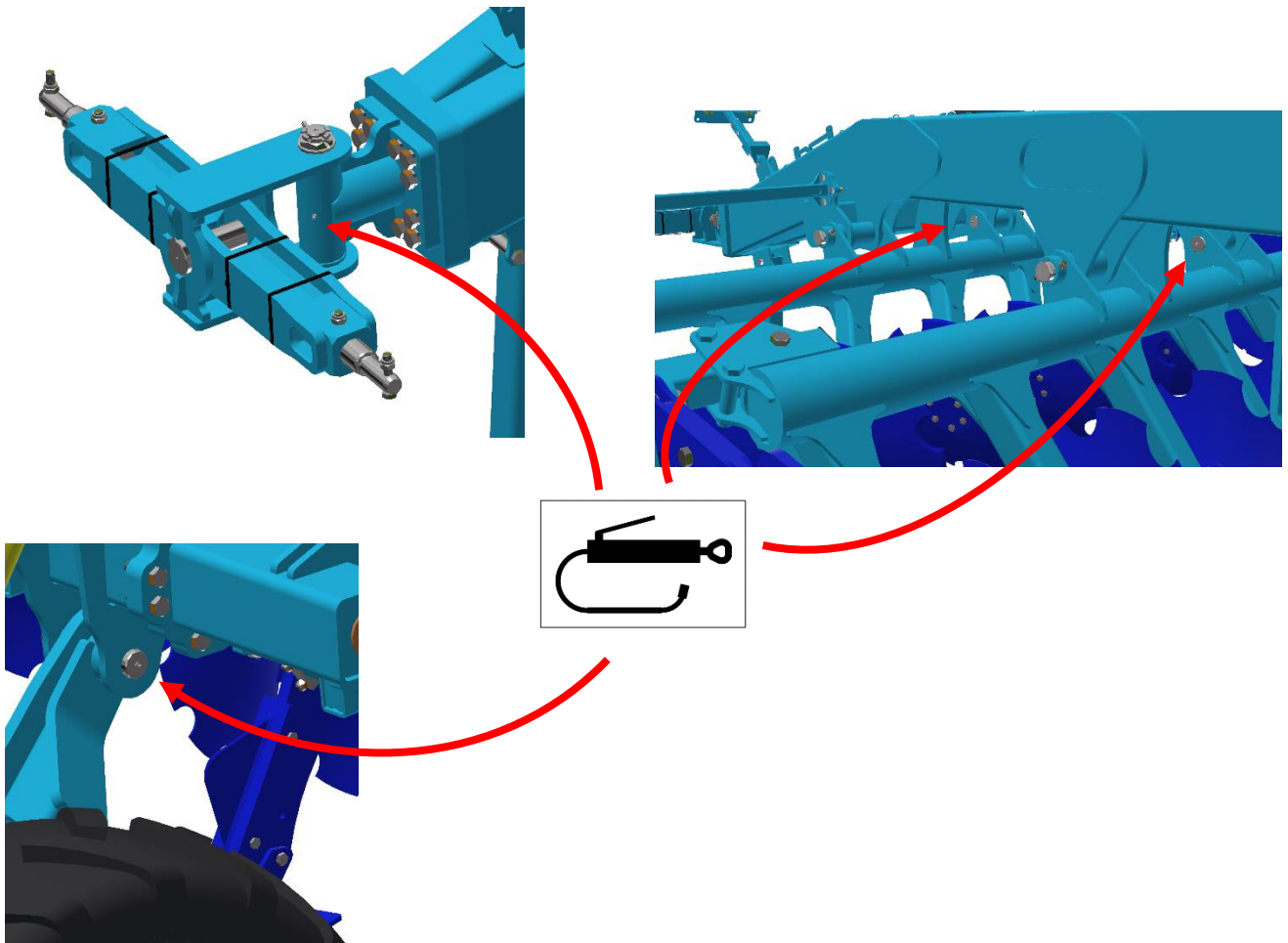

11. ENVIRONMENTAL PROTECTION

- Regularly check the tightness of the hydraulic system.
- Preventively replace or repair hydraulic hoses, possibly further parts of the hydraulic system showing signs of damage before oil leaks occur.
- Check the condition of hydraulic hoses and perform their timely replacement. The service life of hydraulic hoses includes the time when they were stored.
- Handle oils and greases according to valid waste laws and regulations.

12. MACHINE DISPOSAL AFTER SERVICE LIFE EXPIRY

- The operator must secure during machine disposal that steel parts and parts, in which hydraulic oil or lubricating grease moves are differentiated.
- Steel parts must be cut by the operator while observing safety regulations and handed over to the secondary raw material collection point. He must proceed with other parts according to valid laws about waste.

13. SERVICING AND WARRANTY CONDITIONS

13.1 SERVICING

Servicing is secured by the dealer after consulting with the manufacturer, possibly directly by the manufacturer. Spare parts then using the sales network by individual sellers in the entire country. Use only the spare parts according to the spare parts catalogue officially issued by the manufacturer.

13.2 WARRANTY

- 13.2.1** The manufacturer provides a warranty of 24 months for these machine parts: main frame, axle, and machine tow bar. For other parts of the machine, the manufacturer provides a warranty of 12 months. The warranty is provided from the date of sale of the new machine to the end user (consumer).
- 13.2.2** The warranty applies to hidden defects that will show in the warranty period with proper use of the machine and while fulfilling the conditions stated in the operating manual.
- 13.2.3** The warranty does not apply to wearable spare parts, i.e. regular mechanical wear and tear of replaceable parts of the working sections (shares, edges, etc.).
- 13.2.4** The warranty does not apply to indirect consequences of possible damage, such as service life decrease etc.
- 13.2.5** The warranty is bound to the machine and is not void upon an owner change.
- 13.2.6** The warranty is limited to the disassembly and assembly, possibly replacement or repair of the defective part. The decision, whether to replace or repair the defective part, is up to the contractual workshop of Farmet.
- 13.2.7** During the warranty period, only the authorised servicing technician of the manufacturer may perform repairs or other interventions into the machine. In the opposite case, the warranty will not be acknowledged. This provision does not apply to the replacement of wearable spare parts (see point 13.2.3).
- 13.2.8** The warranty is conditioned by using the genuine spare parts of the manufacturer.

(CZ) **ES PROHLÁŠENÍ O SHODĚ**
 (G) **CE CERTIFICATE OF CONFORMITY**
 (D) **EG-KONFORMITÄTSEKTLÄRUNG**
 (F) **DÉCLARATION CE DE CONFORMITÉ**
 (R) **СЕРТИФИКАТ СООТВЕТСТВИЯ ЕС**
 (PL) **DEKLARACJA ZGODNOŚCI WE**

1. (CZ) My (G) We (D) Wir (F) Nous (R) Мы (PL) My: **Farmet a.s.**
 Jiřinková 276
 552 03 Česká Skalice
 Czech Republic
 DIČ: CZ46504931
 Tel/Fax: 00420 491 450136

(CZ) Vydáváme na vlastní zodpovědnost toto prohlášení. (G) Hereby issue, on our responsibility, this Certificate. (D) Geben in alleiniger Verantwortung folgende Erklärung ab. (F) Publiions sous notre propre responsabilité la déclaration suivante. (R) Под свою ответственность выдаем настоящий сертификат. (PL) Wydajemy na własną odpowiedzialność niniejszą Deklarację Zgodności.

2. (CZ) Strojní zařízení: - název : **Купřič**
 (G) Machine: - name : **Cultivator**
 (D) Fabrikat: - Bezeichnung : **Grubber**
 (F) Machinerie: - dénomination : **Cultivateur**
 (R) Сельскохозяйственная машина: - наименование : **Культиватор**
 (PL) Urządzenie maszynowe: - nazwa : **Spulchniarka**

- typ, type : **TRITON HEAVY**
 - model, modèle : **TRNH 300 P**
 - PIN/VIN:

- (CZ) výrobní číslo :
 - (G) serial number
 - (D) Fabriknummer
 - (F) n° de production
 - (R) заводской номер
 - (PL) numer produkcyjny

3. (CZ) Příslušná nařízení vlády: č.176/2008 Sb. (směrnice 2006/42/ES). (G) Applicable Governmental Decrees and Orders: No.176/2008 Sb. (Directive 2006/42/ES). (D) Einschlägige Regierungsverordnungen (NV): Nr.176/2008 Slg. (Richtlinie 2006/42/ES). (F) Décrets respectifs du gouvernement: n°.176/2008 du Code (directive 2006/42/CE). (R) Соответствующие постановления правительства: № 176/2008 Сб. (инструкция 2006/42/ES). (PL) Odpowiednie rozporządzenia rządowe: nr 176/2008 Dz.U. (Dyrektywa 2006/42/WE).

4. (CZ) Normy, s nimiž byla posouzena shoda: (G) Standards used for consideration of conformity: (D) Das Produkt wurde gefertigt in Übereinstimmung mit folgenden Normen: (F) Normes avec lesquelles la conformité a été évaluée: (R) Normы, на основании которых производилась сертификация: (PL) Normy, według których została przeprowadzona ocena: ČSN EN ISO 12100, ČSN EN ISO 4254-1.

(CZ) Schválil (G) Approved by dne: 01.10.2022
 (D) Bewilligen (F) Approuvé
 (R) Утвердил (PL) Uchwalit

V České Skalici dne: 01.10.2022

Ing. Petr Lukášek
 technický ředitel
 Technical Director

Ing. Karel Žďárský
 generální ředitel společnosti
 General Manager

Farmet a.s.
 Jiřinková 276
 552 03 Česká Skalice
 DIČ CZ46504931
 59